

***BID AND CONTRACT DOCUMENTS
AND SPECIFICATIONS
FOR***

***21ST AVE S & S 320TH STREET SIGNALIZATION AND
PEDESTRIAN IMPROVEMENTS***

***PROJECT # 36225
RFB # 23-015***

***City of Federal Way
Public Works Department
33325 8th Avenue South
Federal Way, WA 98003***

**BID AND CONTRACT DOCUMENTS AND SPECIFICATIONS
FOR
21ST AVE S & S 320TH STREET SIGNALIZATION AND PEDESTRIAN
IMPROVEMENTS**

**PROJECT # 36225
RFB # 23-015**

Bids Accepted Until 10:00 a.m., December 20, 2023 at
City of Federal Way
33325 8th Avenue South
Federal Way, WA 98003

Prepared By:
Fehr & Peers
1001 Fourth Ave, Suite 4120
Seattle, WA 98154

&

KPFF Consulting Engineers
1601 Fifth Ave, Suite 1600
Seattle, WA 98101



EXPIRES 08/24/25



12/01/23

The contract plans and specifications for this Project have been reviewed and approved by:

A handwritten signature in blue ink that reads "Jenni S. Wilson".

Public Works Director / Deputy Public Works Director

CITY OF FEDERAL WAY

**21ST AVE S & S 320TH ST SIGNALIZATION
AND PEDESTRIAN IMPROVEMENTS
PROJECT #36225**

RFB-i

CFW RFB VERSION 2023-APR

*** PLAN CENTER COPY *** Official bid documents, plan holder's list, and addenda (if applicable) are available on BXWA.com

TABLE OF CONTENTS

PAGE

ADVERTISEMENT FOR BIDS	1
INSTRUCTIONS TO BIDDERS & CHECKLISTS	2
BID PROPOSAL	4
BID BOND.....	10
SUBCONTRACTOR LIST	11
CONTRACTOR WAGE LAW COMPLIANCE CERTIFICATION	12
PROPOSAL FOR INCORPORATING RECYCLED MATERIALS.....	13
PUBLIC WORKS CONTRACT	14
SAMPLE CONTRACT CHANGE ORDER	21
CERTIFICATE OF INSURANCE	23
PERFORMANCE AND PAYMENT BOND	24
CONTRACTOR’S RETAINAGE OPTION	26
RETAINAGE BOND TO CITY OF FEDERAL WAY	27
SPECIAL PROVISIONS	
STANDARD PLANS AND DETAILS.....	
PREVAILING WAGES AND BENEFIT CODE KEY.....	
PROJECT PLANS	BOUND SEPARATELY

ADVERTISEMENT FOR BIDS

21ST AVE S & S 320TH STREET SIGNALIZATION AND PEDESTRIAN IMPROVEMENTS

SUBMITTAL OF SEALED BIDS: Notice is hereby given that the City of Federal Way will receive sealed bids through December 20, 2023, at 10:00 a.m. at the City Hall Finance Department at 33325 8th Avenue South, Federal Way, Washington 98003. Proposals received after said date and time will not be considered. All timely bids will be opened and read publicly aloud in the City Council Chambers , City Hall 33325 8th Avenue South, Federal Way, Washington 98003 at 10:05 a.m. on December 20, 2023.

This project shall consist of: Construction of signal poles and associated conduits and wiring, median island with pedestrian push buttons, and curb ramps. Conduits under the roadway shall be constructed by directional boring.

The City anticipates awarding this project to the successful bidder and intends to give Notice to Proceed as soon as the Contract and all required documents are executed in full. Regardless of the date of award or Notice to Proceed, the Contractor must complete all work within 140 working days.

BID DOCUMENTS: Plans, Specifications, Addenda, and plan holders list are available on-line through Builders Exchange of Washington at www.bxwa.com. Click on: "Posted Projects," "Public Works," and "City of Federal Way." It is recommended that Bidders "Register" in order to receive automatic e-mail notification of future addenda and to place themselves on the "Bidders List." Bidders that do not register will need to periodically check on-line for addenda issued on this project. Contact Builders Exchange of Washington at (425) 258-1303 if you require assistance with access or registration. An informational copy of plans, specifications, and addenda are available for viewing only at the City of Federal Way Finance Department.

QUESTIONS: Any questions must be directed to John Mulkey, Senior Civil Engineer, by email at john.mulkey@cityoffederalway.com, or by letter addressed to same. Questions must be received by the City no later than 5:00 p.m. three business days preceding the bid opening to allow a written reply to reach all prospective Bidders before the submission of bids.

OTHER PROVISIONS: All bids and this Project shall be governed by the Contract, as defined by the Washington State Department of Transportation Standard Specifications for Road, Bridge, and Municipal Construction 2023 (Standard Specifications), which is incorporated by this reference as though set forth in full.

All bid proposals shall be in accordance with the Contract and all bid proposals shall be accompanied by a bid deposit or bond in the amount required in the Contract. Forfeiture of the proposal bond or deposit to the City shall be in accordance with the Contract.

The recipient, in accordance with Title VI of the Civil Rights Act of 1964, (78 Stat. 252, 42 U.S.C. 2000d to 2000d-4) and the Regulations, hereby notifies all bidders that it will affirmatively ensure that in any contract entered into pursuant to this advertisement, disadvantaged business enterprises will be afforded full and fair opportunity to submit bids in response to this invitation and will not be discriminated against on the grounds of race, color or national origin in consideration for an award. The City encourages minority and women-owned firms to submit bids consistent with the City's policy to ensure that such firms are afforded the maximum practicable opportunity to compete for and obtain public contracts.

The City of Federal Way reserves the right to reject any and all bids, waive any informalities or minor irregularities in the bidding, and determine which bid or bidder meets the criteria set forth in the bid documents.

DATES OF PUBLICATION:

Daily Journal of Commerce
Federal Way Mirror

Publish December 4, 2023 and December 11, 2023
Publish December 8, 2023 and December 15, 2023

CITY OF FEDERAL WAY

**21ST AVE S & S 320TH ST SIGNALIZATION
AND PEDESTRIAN IMPROVEMENTS
PROJECT #36225**

RFB-1

CFW RFB VERSION 2023-APR

***** PLAN CENTER COPY *** Official bid documents, plan holder's list, and addenda (if applicable) are available on BXWA.com**

INSTRUCTIONS TO BIDDERS & CHECKLISTS

(1) ADVERTISEMENT FOR BIDS AND CONTRACT DOCUMENTS

The Advertisement for Bids and Contract Documents contain bidder instructions that must be complied with.

(2) EXAMINATION OF BID AND CONTRACT DOCUMENTS – BIDDER RESPONSIBILITIES

The submission of a bid shall constitute an acknowledgment upon which the City may rely that the bidder has thoroughly examined and is familiar with the bid and Contract Documents, the Project site, the availability of materials and labor, publically available information, and has reviewed and inspected all applicable federal, state, and local statutes, regulations, ordinances and resolutions dealing with or related to the equipment and/or services to be provided herein. The failure or neglect of a bidder to examine such documents, statutes, regulations, ordinances or resolutions shall in no way relieve the bidder from any obligations with respect to the bidder's bid or the contract documents. No claim for additional compensation will be allowed which is based upon a lack of knowledge of any contract documents, statutes, regulations, ordinances or resolutions. Bidders shall visit delivery and service locations(s) as required. Bidders shall become familiar with and verify any environmental factors, which may impact current or future prices for this requirement.

(3) INTERPRETATION OF BID AND CONTRACT DOCUMENTS

No oral clarifications, interpretations, or representation will be made to any bidder as to the meaning of the bid or Contract Documents. Bidders shall not rely upon any oral statement or conversation they may have with City's employees, agents, representatives, consultants, or design professionals regarding the Contract Documents, whether at the pre-bid meeting or otherwise and no oral communications will be binding upon the City. Any questions must be directed to John Mulkey, P.E., Senior Civil Engineer, by email at john.mulkey@cityoffederalway.com, or by letter addressed to same. The questions must be received by the City no later than 5:00 p.m. three business days preceding the bid opening to allow a written reply to reach all prospective Bidders before the submission of their bids. Any interpretation deemed necessary by the City will be in the form of an Addendum to the bid documents and when issued will be sent as promptly as is practical to all parties to whom the bid documents have been issued. All such Addenda shall become part of the bid.

(4) BID PRICE

The bid price shall include everything necessary for the completion of the Contract and the Work including, but not limited to, furnishing all materials, equipment, tools, freight charges, facilities and all management, superintendence, labor and service, except as may be provided otherwise in the Contract Documents. All Washington State sales tax and all other government taxes, assessments and charges shall be included in the various Bid item prices as required by law. The offer shall remain in effect ninety (90) days after the bid opening.

(5) POSTPONEMENT OF BID OPENING

The City reserves the right to postpone the date and time for the opening of bids by Addendum at any time prior to the bid opening date and time announced in these documents.

(6) REJECTION OF BIDS

The City reserves the right to reject any bid for any reason including, but not limited to, the reasons listed in Special Provisions Section 1-02.13. The City further reserves the right to reject any portion of any bid and/or to reject all bids. In consideration for the City's review and evaluation of its bid, the bidder waives and releases any claims against the City arising from any rejection of any or all bids. If, in the opinion of the City, there is reason to believe that collusion exists among bidders, none of the bids of the participants in such collusion will be considered.

(7) RECYCLED PRODUCTS

CITY OF FEDERAL WAY

**21ST AVE S & S 320TH ST SIGNALIZATION
AND PEDESTRIAN IMPROVEMENTS
PROJECT #36225**

RFB-2

CFW RFB VERSION 2023-APR

***** PLAN CENTER COPY *** Official bid documents, plan holder's list, and addenda (if applicable) are available on BXWA.com**

The Contractor shall use recycled paper for proposals and for any printed or photocopied material created pursuant to a contract with the City whenever practicable and use both sides of paper sheets for reports submitted to the City whenever practicable.

(8) BIDDER'S CHECKLIST

The bidder's attention is especially called to the following forms, which must be executed in full as required. Failure to comply may result in rejection of any bid not so complying.

- Bid Proposal**: The Bid Proposal shall be completed and fully executed, including filling in the total bid amount.
- Bid Bond**: This form is to be executed by the bidder (and the surety company as appropriate, depending upon the option selected by the bidder).
- Subcontractor List**: The Subcontractor List shall be filled in by the bidder.
- Contractor Certification – Wage Law Compliance**: This form shall be filled in and fully executed by the bidder.
- Proposal for Incorporating Recycled Materials**: This form shall be filled in and executed by the bidder.
- Apprenticeship Plan**: This form shall be filled in by the bidder.

(9) CONTRACT CHECKLIST

The following documents are to be executed and delivered to the City after the Bid is awarded:

- Public Works Contract**: The successful bidder will fully execute and deliver to the City the Public Works Contract ("Contract") from these Bid Documents.
- Certificate of Insurance**: The successful bidder will provide a Certificate of Insurance evidencing the insurance requirement set forth in the Contract.
- Performance/Payment Bond**: The successful bidder will provide a fully executed Performance/Payment Bond as appropriate.
- Contractor's Retainage Option**: The successful bidder will fully execute and deliver to the City the Contractor's Retainage Option.
- Contractor's Retainage Bond**: If the retainage bond option is chosen, then the successful bidder will fully execute and deliver to the City the Contractor's Retainage Bond.
- Business License**: The successful bidder will provide a copy of a current Business License with the City of Federal Way.

BID PROPOSAL

21ST AVE S & S 320TH STREET SIGNALIZATION AND PEDESTRIAN IMPROVEMENTS

PROPOSAL SUBMITTED TO:

City of Federal Way
33325 8th Ave South
Federal Way, Washington 98003-6325

PROPOSAL SUBMITTED BY:

Bidder: _____
Full Legal Name of Firm

Contact: _____
Individual with Legal Authority to sign Bid and Contract

Address: _____
Street Address

City, State Zip

Phone: _____

E-Mail: _____

- Select One of the Following:
- Corporation
 - Partnership.
 - Individual
 - Other

State Contractor's License No.: _____

State Contractor's License Expiration Date: _____ / _____ / _____
Month Day Year

State UBI No.: _____

State Worker's Comp. Account No.: _____

NOTE: All entries shall be written in ink or typed. Unit prices for all items, all extensions, and total amount of bid shall be shown. Enter unit prices in numerical figures only, in dollars and cents to two (2) decimal places (including for whole dollar amounts). All figures must be clearly legible. Bids with illegible figures in the unit price column will be regarded as nonresponsive. Where conflict occurs between the unit price and the total amount specified for any item, the unit price shall prevail, and totals shall be corrected to conform thereto. The Bidder shall complete this entire Bid Form or this bid may be considered non-responsive. The City may correct obvious mathematical errors. The City of Federal Way reserves the right to reject any and all bids, waive any informalities or minor irregularities in the bidding, and determine which bid or bidder meets the criteria set forth in the bid documents.

SCHEDULE A: SIGNAL IMPROVEMENTS All unit prices shall include applicable sales tax (Roadway Improvements)						
Item No.	Spec. Div.	Bid Item Description	Unit	Plan Qty	Unit Price	Amount
1	1-04	MINOR CHANGES	FA	1	\$25,000.00	\$25,000.00
2	1-05	ROADWAY SURVEYING	LS	1	\$	\$
3	1-05	ADA FEATURES SURVEYING	LS	1	\$	\$
4	1-05	AS-BUILT SURVEY AND RECORD DRAWINGS	LS	1	\$	\$
5	1-09	MOBILIZATION	LS	1	\$	\$
6	1-10	TRAFFIC CONTROL SUPERVISOR	LS	1	\$	\$
7	1-10	FLAGGERS	HR	720	\$	\$
8	1-10	OTHER TRAFFIC CONTROL LABOR	HR	120	\$	\$
9	1-10	OTHER TEMPORARY TRAFFIC CONTROL DEVICES	LS	1	\$	\$
10	1-10	PORTABLE CHANGEABLE MESSAGE SIGN	HR	3072	\$	\$
11	1-10	SEQUENTIAL ARROW SIGN	HR	3380	\$	\$
12	1-10	CONSTRUCTION SIGNS CLASS A	SF	588	\$	\$
13	1-10	WORK ZONE SAFETY CONTINGENCY	FA	1	\$ 25,000	\$ 25,000
14	2-01	CLEARING AND GRUBBING	LS	1	\$	\$
15	2-01	ROADSIDE CLEANUP	FA	1	\$	\$
16	2-02	REMOVAL OF STRUCTURES AND OBSTRUCTIONS	LA	1	\$	\$

CITY OF FEDERAL WAY

21ST AVE S & S 320TH ST SIGNALIZATION
AND PEDESTRIAN IMPROVEMENTS
PROJECT #36225

RFB-5
CFW RFB VERSION 2023-APR

*** PLAN CENTER COPY *** Official bid documents, plan holder's list, and addenda (if applicable) are available on BXWA.com

17	2-03	ROADWAY EXCAVATION INCL. HAUL	CY	100	\$	\$
18	8-22	REMOVING PAVEMENT MARKINGS	LS	1	\$	\$
19	4-02	CRUSHED SURFACING TOP COURSE	TON	60	\$	\$
20	5-04	HMA CL 1/2" PG58H-22	TON	60	\$	\$
21	5-04	PLANING BITUMINOUS PAVEMENT	SY	160	\$	\$
22	8-04	CEMENT CONCRETE TRAFFIC CURB AND GUTTER	LF	210	\$	\$
23	8-04	CEMENT CONCRETE PEDESTRIAN CURB	LF	200	\$	\$
24	8-04	EXTRUDED CURB TYPE 6	LF	190	\$	\$
25	8-04	DOUBLE WIDE CEMENT CONCRETE CURB	LF	40	\$	\$
26	8-07	DUAL FACED SLOPED MOUNTABLE CURB	LF	100	\$	\$
27	8-14	CEMENT CONC. SIDEWALK	SY	240	\$	\$
28	8-14	CEMENT CONC. CURB RAMP TYPE PARALLEL	EA	2	\$	\$
29	8-14	CEMENT CONC. CURB RAMP TYPE PERPENDICULAR	EA	2	\$	\$
30	8-14	CEMENT CONC. CURB RAMP TYPE SINGLE DIRECTION	EA	1	\$	\$
31	8-14	DETECTABLE WARNING SURFACE	SF	24	\$	\$
32	8-31	CURB WALL	CY	10	\$	\$
33	6-02	GRAVEL BACKFILL FOR WALL	CY	3	\$	\$
34	6-06	44" BREAKAWAY CABLE PEDESTRIAN RAILING	LF	83	\$	\$
35	7-05	ADJUST CATCH BASIN	EA	3	\$	\$
36	7-12	ADJUST WATER VALVE TO GRADE	EA	3	\$	\$
37	8-20	ADJUST JUNCTION BOX TO GRADE	EA	3	\$	\$

CITY OF FEDERAL WAY

21ST AVE S & S 320TH ST SIGNALIZATION
AND PEDESTRIAN IMPROVEMENTS
PROJECT #36225

RFB-6

CFW RFB VERSION 2023-APR

*** PLAN CENTER COPY *** Official bid documents, plan holder's list, and addenda (if applicable) are available on BXWA.com

38	8-30	POTHOLING	FA	1	\$ 5,000.00	\$ 5,000.00
39	8-30	RESOLUTION OF UTILITY CONFLICTS	FA	1	\$ 5,000.00	\$ 5,000.00
40	8-22	PAINTED WIDE LINE	LF	35	\$	\$
41	8-22	PLASTIC STOP LINE	LF	120	\$	\$
42	8-22	PLASTIC CROSSWALK LINE	SF	780	\$	\$
43	8-22	PLASTIC TRAFFIC ARROW	EA	6	\$	\$
44	1-07	SPCC PLAN	LS	1	\$	\$
45	8-01	EROSION CONTROL AND WATER POLLUTION CONTROL	LS	1	\$	\$
46	8-20	TRAFFIC SIGNAL SYSTEM COMPLETE	LS	1	\$	\$
47	8-02	TOPSOIL TYPE A	CY	13	\$	\$
48	8-02	BARK MULCH	CY	9	\$	\$
49	8-02	PROPERTY RESTORATION	FA	1	\$ 2,000.00	\$ 2,000.00
TOTAL – SCHEDULE A						\$

BID SUMMARY	
ITEM	BID AMOUNT
SCHEDULE A: SIGNAL	\$
TOTAL BID AMOUNT <i>(including Washington State sales tax, all other government taxes, assessments and charges)</i>	\$

The documents incorporated by reference, as if fully set forth, are the Advertisement for Bids, the Instructions to Bidders and Checklists, the Contractor's Bid Proposal (including all forms and supplemental information listed on the Bidders Checklist), the Contract Documents (including Project Plans, Specifications, and all Appendices, Amendments, and Supplemental Reports & Information), the Contract Provisions (including all forms and supplemental information listed on the Contract Checklist), the version of the Washington State Standard Specifications for Road, Bridge, and Municipal Construction identified herein, and any other documents provided to bidders and/or referenced in or referred to by the Contract Documents.

CITY OF FEDERAL WAY

**21ST AVE S & S 320TH ST SIGNALIZATION
AND PEDESTRIAN IMPROVEMENTS
PROJECT #36225**

RFB-7

CFW RFB VERSION 2023-APR

*** PLAN CENTER COPY *** Official bid documents, plan holder's list, and addenda (if applicable) are available on BXWA.com

Pursuant to and in compliance with the Advertisement for Bids for the Project, and other documents relating thereto, the undersigned has carefully examined all of the bid and contract documents, considered conditions which may affect the delivery, supply and maintenance for the Project, and hereby proposes to furnish all labor, materials and perform all work as required in strict accordance with the contract documents, for the referenced bid amount, inclusive of Washington State sales tax and all other government taxes, assessments and charges as required by law.

NON-COLLUSION AFFIDAVIT

By signing this proposal, the undersigned acknowledges that the person(s), firm, association, or corporation has (have) not, either directly or indirectly, entered into any agreement, participated in any collusion, or otherwise taken any action in restraint of free competitive bidding in connection with this project.

To report rigging activities, call 1-800-424-9071. The U.S. Department of Transportation (USDOT) operates the toll-free hotline Monday through Friday, 8:00 a.m. to 5:00 p.m., Eastern Time. Anyone with knowledge of possible bid rigging, bidder collusion, or other fraudulent activities should use the hotline to report such activities. The hotline is part of USDOT's continuing effort to identify and investigate highway construction contract fraud and abuse and is operated under the direction of the USDOT Inspector General. All information will be treated confidentially and caller anonymity will be respected.

CONFLICTS OF INTEREST, GRATUITIES, & NON-COMPETITIVE PRACTICES

By signing this proposal, the undersigned agrees as follows:

- (1) That it has no direct or indirect pecuniary or proprietary interest, that it shall not acquire any interest which conflicts in any manner or degree with the work, services, equipment or materials required to be performed and/or provided under this contract and that it shall not employ any person or agent having any such interests. In the event that the Contractor or its agents, employees or representatives hereafter acquires such a conflict of interest, it shall immediately disclose such interest to the City and take action immediately to eliminate the conflict or to withdraw from this contract, as the City may require; and
- (2) That no person or selling agency except bona fide employees or designated agents or representatives of the Contractor have been employed or retained to solicit or secure this contract with an agreement or understanding that a commission, percentage, brokerage, or contingent fee would be paid; and
- (3) That no gratuities in the form of entertainment, gifts or otherwise, were offered or given by the Contractor or any of its agents, employees or representatives, to any official, member or employee of the City or other governmental agency with a view toward securing this contract or securing favorable treatment with respect to the awarding or amending, or the making of any determination with respect to the performance of this contract.

AFFIDAVIT OF ELIGIBILITY

The Contractor certifies that it is properly licensed and registered under the laws of the State of Washington and has not been determined to have been in violation of RCW 50.12.070(1)(b), RCW 51.16.070(1)(b), or RCW 82.32.070(2) within the last two years. The Contractor further certifies that it has not been determined, within the last one year, to have committed any combination of two of the following violations or infractions within a five year period: (1) Violated RCW 51.48.020(1) or 51.48.103; or (2) Committed an infraction or violation under Chapter 18.27 RCW.

CERTIFICATION OF LAWFUL EMPLOYMENT

The Contractor hereby certifies that it has complied with all provisions of the Immigration and Nationality Act now or as herein after amended, 8 U.S.C. 1101 et. Seq., and that all employees, including subcontractor employees, are lawfully permitted to perform work in the United States as provided in this agreement with the City of Federal Way.

Receipt of the following Addendums is hereby acknowledged:

CITY OF FEDERAL WAY

**21ST AVE S & S 320TH ST SIGNALIZATION
AND PEDESTRIAN IMPROVEMENTS
PROJECT #36225**

RFB-8

CFW RFB VERSION 2023-APR

Addendum No. ____ Date Issued: _____

Addendum No. ____ Date Issued: _____

Addendum No. ____ Date Issued: _____

The undersigned individual represents and warrants that he or she is dully authorized to execute the bid and all bid documents on behalf of any partnership, joint venture or corporation.

By: _____
Signature

Printed Name

Title

Subscribed and sworn to before me this ____ day of _____, 20__.

Signature of Notary

Printed name of Notary
Notary Public in and for the State of Washington
My commission expires: _____

BID BOND

21ST AVE S & S 320TH STREET SIGNALIZATION AND PEDESTRIAN IMPROVEMENTS

OPTION 1: BID BOND DEPOSIT

Attached is a deposit in the form of a certified check, cashier's check, or cash in the amount of \$ _____, which amount is not less than five percent (5%) of the total bid.

Principal – Signature of Authorized Official *Date*

Title

—OR—

OPTION 2: BID BOND

KNOW ALL PERSONS BY THESE PRESENTS that we, _____, as Principal, and _____, as Surety, are held and firmly bound unto the City of Federal Way, as Obligee, in the sum of five (5) percent of the total amount of the bid proposal for the payment of which the Principal and the Surety bond themselves, their heirs and executors, administrators, successors and assigns, jointly and severally, by these presents.

The condition of this obligation is such that if the Obligee shall make any award to the Principal for the above-mentioned Project according to the terms of the proposal or bid made by the Principal therefore, and the Principal shall duly make and enter into a contract with the Obligee in accordance with the terms of said proposal or bid and award and shall give bond for the faithful performance thereof, with Surety or Sureties approved by the Obligee; or if the Principal shall in case of failure so to do, pay and forfeit to the Obligee the penal amount of the deposit specified in the call for bids, then this obligation shall be null and void; otherwise, it shall be, and remain in full force and effect, and the Surety shall forthwith pay and forfeit to the Obligee as penalty and liquidated damages, the amount of this bond.

SIGNED, SEALED AND DATED THIS ____ DAY OF _____, 20____.

Principal – Signature of Authorized Official

Surety – Attorney in Fact
(Attach Power of Attorney)

Title

Name and Address of Local Office/Agent of Surety Company is:

SUBCONTRACTOR LIST



Subcontractor List

Prepared in compliance with RCW 39.30.060 as amended

To Be Submitted with the Bid Proposal

Project Name _____

Failure to list subcontractors with whom the bidder, if awarded the contract, will directly subcontract for performance of the work of structural steel installation, rebar installation, heating, ventilation and air conditioning, plumbing, as described in Chapter 18.106 RCW, and electrical, as described in Chapter 19.28 RCW or naming more than one subcontractor to perform the same work will result in your bid being non-responsive and therefore void.

Subcontractor(s) with whom the bidder will directly subcontract that are proposed to perform the work of structural steel installation, rebar installation, heating, ventilation and air conditioning, plumbing, as described in Chapter 18.106 RCW, and electrical as described in Chapter 19.28 RCW must be listed below. The work to be performed is to be listed below the subcontractor(s) name.

To the extent the Project includes one or more categories of work referenced in RCW 39.30.060, and no subcontractor is listed below to perform such work, the bidder certifies that the work will either (i) be performed by the bidder itself, or (ii) be performed by a lower tier subcontractor who will not contract directly with the bidder.

Subcontractor Name _____
Work to be performed _____

Subcontractor Name _____
Work to be performed _____

Subcontractor Name _____
Work to be performed _____

Subcontractor Name _____
Work to be performed _____

Subcontractor Name _____
Work to be performed _____

* Bidder's are notified that it is the opinion of the enforcement agency that PVC or metal conduit, junction boxes, etc, are considered electrical equipment and therefore considered part of electrical work, even if the installation is for future use and no wiring or electrical current is connected during the project.

DOT Form 271-015
Revised 06/2020

CITY OF FEDERAL WAY

**21ST AVE S & S 320TH ST SIGNALIZATION
AND PEDESTRIAN IMPROVEMENTS
PROJECT #36225**

RFB-11

CFW RFB VERSION 2023-APR

CONTRACTOR WAGE LAW COMPLIANCE CERTIFICATION

FAILURE TO RETURN THIS CERTIFICATION AS PART OF THE BID PROPOSAL PACKAGE WILL MAKE THIS BID NONRESPONSIVE AND INELIGIBLE FOR AWARD.

I hereby certify, under penalty of perjury under the laws of the State of Washington, on behalf of the firm identified below that, to the best of my knowledge and belief, this firm has **NOT** been determined by a final and binding citation and notice of assessment issued by the Washington State Department of Labor and Industries or through a civil judgment entered by a court of limited or general jurisdiction to have willfully violated, as defined in RCW 49.48.082, any provision of Chapters 49.46, 49.48, and 49.52 RCW within three (3) years prior to the date of the Request for Bids.

Bidder Name: _____
Print Full Legal Name of Firm

By: _____
Signature of Authorized Person *Print Name of Person Making Certifications for Firm*

Title: _____
Title of Person Signing Certificate Place: _____
Print City and State Where Signed

Date: _____

PROPOSAL FOR INCORPORATING RECYCLED MATERIALS



APWA-WA Division 1 Committee

rev. 1/8/2016

Proposal for Incorporating Recycled Materials into the Project

In compliance with a new law that went into effect January 1, 2016 (SHB1695), the Bidder shall propose below, the total percent of construction aggregate and concrete materials to be incorporated into the Project that are recycled materials. Calculated percentages must be within the amounts allowed in Section 9-03.21(1)E, Table on Maximum Allowable Percent (By Weight) of Recycled Material, of the Standard Specifications.

Proposed total percentage: _____ percent.

Note: Use of recycled materials is highly encouraged within the limits shown above, but does not constitute a Bidder Preference, and will not affect the determination of award, unless two or more lowest responsive Bid totals are exactly equal, in which case proposed recycling percentages will be used as a tie-breaker, per the APWA GSP in Section 1-03.1 of the Special Provisions. Regardless, the Bidder's stated proposed percentages will become a goal the Contractor should do its best to accomplish. Bidders will be required to report on recycled materials actually incorporated into the Project, in accordance with the APWA GSP in Section 1-06.6 of the Special Provisions.

Bidder: _____

Signature of Authorized Official: _____

Date: _____

PUBLIC WORKS CONTRACT

THIS PUBLIC WORKS CONTRACT ("Contract") is dated effective this _____ day of _____, 20____ and is made by and between the City of Federal Way, a Washington municipal corporation ("City or Owner"), and _____, a _____ ("Contractor"), for the project known as _____ (the "Project").

A. The City desires to retain an independent contractor to furnish all labor and materials necessary to perform work necessary to complete the Project; and

B. The Contractor has the requisite skill and experience to perform such work.

NOW, THEREFORE, the parties ("Parties") agree to the following terms and conditions:

1. SERVICES BY CONTRACTOR

Contractor shall perform all Work and furnish all tools, materials, supplies, equipment, labor and other items incidental thereto necessary for the construction and completion of the Project. Contractor shall perform the Work in a manner consistent with accepted practices for other properly licensed contractors and in accordance with and as described in the Contract Documents, which Work shall be completed to the City's satisfaction, within the time period prescribed by the City and pursuant to the direction of the Mayor or his or her designee.

2. TERM

2.1 This Contract shall commence on the effective date of this Contract and continue until the Project is formally accepted as complete by the City Council, Notice of Project Completion is filed with State agencies, and all bonds for the Project are released by the City.

2.2 The Contractor must complete the Work in accordance with the number of Working Days for the Project as identified in the Contract Documents. With regard to obtaining Substantial Completion and the Completion Date by the Contractor, time is of the essence. In the event the Work is not substantially completed within the time specified in the Contract Documents, Contractor agrees to pay to the City liquidated damages in the amount set forth in the Contract Documents. The parties acknowledge that delays inconvenience the public and cost taxpayers undue sums of money, adding time needed for administration, inspection, and supervision of the Project and diverting City resources from other projects and obligations.

2.3 If the Contractor is unreasonably delayed by others, notification shall be made in writing to the Engineer in accordance with the Contract Documents. Any request for a time extension or additional compensation (including expectancy or consequential damages) allegedly resulting from such delay shall be made in accordance with the procedures of the Contract Documents. Failure to follow the notice procedures in the Contract Documents is a full and complete waiver of Contractor's right to additional time, money, damages, or other relief (including expectancy or consequential damages) as a result of the event or condition giving rise to such request.

3. COMPENSATION

3.1 In consideration of the Contractor performing the Work, the City agrees to pay the Contractor an amount not to exceed _____ and ____/100 Dollars (\$ _____), which amount shall constitute full and complete payment by the City ("Total Compensation"). The Contractor shall be solely responsible for the payment of any taxes imposed by any lawful jurisdiction as a result of the performance and payment of this Contract.

3.2 The City shall pay the Contractor for Work performed under this Contract as detailed in the Bid Proposal, which is incorporated herein and made a part hereof by this reference, and as detailed in the Contract Documents. The City shall have the right to withhold payment to the Contractor for any of the Work not completed in a satisfactory manner, in the City's sole and absolute discretion, which shall be withheld until such

CITY OF FEDERAL WAY

**21ST AVE S & S 320TH ST SIGNALIZATION
AND PEDESTRIAN IMPROVEMENTS
PROJECT #36225**

RFB-14

CFW RFB VERSION 2023-APR

time as Contractor modifies or repairs the Work so that the Work is acceptable to the City. Payment to the Contractor for partial estimates, final estimates, and retained percentages shall be subject to controlling laws.

3.3 In addition to the requirements set forth in the Contract Documents, the Contractor shall maintain Project cost records by cost codes and shall contemporaneously segregate and separately record, at the time incurred, all costs (1) directly associated with each work activity, (2) directly or indirectly resulting from any event, occurrence, condition, or direction for which Contractor seeks an adjustment in Contract price Contract time, or related to any other Claim or protest. Any work performed for which Contractor intends to seek an adjustment in Contract Price or Contract Time, or related to any other Claim or protest, shall be recorded on the same day the work is performed and kept separate so as to distinguish it from Contract Work.

4. INDEPENDENT CONTRACTOR

4.1 It is the intention and understanding of the Parties that the Contractor shall be an independent contractor and that the City shall be neither liable nor obligated to pay Contractor sick leave, vacation pay or any other benefit of employment, nor to pay any social security or other tax which may arise as an incident of employment. The Contractor shall not conduct itself as nor claim to be an officer or employee of the City. The Contractor shall pay all income and other taxes due. Industrial or any other insurance that is purchased for the benefit of the City, regardless of whether such may provide a secondary or incidental benefit to the Contractor, shall not be deemed to convert this Agreement to an employment contract. It is recognized that Contractor may or will be performing professional services during the Term for other parties; provided, however, that such performance of other services shall not conflict with or interfere with Contractor's ability to perform the Services. Contractor agrees to resolve any such conflicts of interest in favor of the City. Nothing contained in this Contract shall create a contractual or direct relationship with or a cause of action in favor of a Subcontractor or third party against the City, or by the Contractor against the Engineer, or against any of their agents, employees, engineers, or consultants.

4.2 If the Contractor is a sole proprietorship or if this is a contract with an individual, the contractor agrees to notify the City and complete any required form if the Contractor retired under a State of Washington retirement system and agrees to indemnify any losses the City may sustain through the Contractor's failure to do so.

5. INDEMNIFICATION

5.1 Contractor Indemnification.

5.1.1 The Contractor shall indemnify, defend, and hold the City, its elected officials, officers, employees, agents, consultants, and volunteers (collectively "the Indemnified Parties") harmless from any costs or losses, and pay and damages or judgments, related to any claim brought by any person employed in any capacity by the Contractor or subcontractor or supplier (of any tier) performing the Work, with respect to the payment of wages, salaries, or other compensation or benefits including but not limited to benefits such as medical, health, retirement, vacation, sick leave, etc.

5.1.2. To the fullest extent permitted by law, the Contractor shall defend, release, indemnify, and hold harmless the City and the Indemnified Parties for, from, and against any and all claims, demands, losses, costs, damages, suits, actions, expenses, fines, penalties, response costs, and liabilities (including costs and all attorney and expert fees and internal personnel costs of investigation) of whatsoever kind or nature to the extent arising from, resulting from, connected with, or incident to the Contractor's performance or failure to perform this Contract or the Work or its breach of this Contract; provided, however, that if the provisions of RCW 4.24.155 apply to the Work and any injuries to persons or property arising out of the performance of this Contract are caused by or result from the concurrent negligence of the Contractor or its subcontractors, agents, employees, or anyone for whom they are legally liable, and an Indemnified Party, the indemnification and defense obligations under this Section 5.1.2 apply only to the extent of the negligence of the Contractor, its subcontractors, agents, employees, and anyone for whom they are legally liable.

5.1.3 Contractor specifically assumes potential liability for actions brought by the Contractor's own employees or former employees against any Indemnified Party, and for that purpose Contractor waives any immunity that may be granted to it under the Washington State Industrial Insurance Act, Title 51 RCW.

Contractor's indemnification shall not be limited in any way by any limitation on the amount of damages, compensation or benefits payable to or by any third party under workers' compensation acts, disability benefit acts or any other benefits acts or programs. Provided, however, the Contractor's waiver of immunity by the provisions of this paragraph extends only to claims against the Contractor by any Indemnified party, and does not include, or extend to, any claims by the Contractor's employee directly against the Contractor. The Contractor recognizes that this waiver was specifically entered into.

5.2 Contractor Release. Any deviation, alteration, variation, addition, or omission in the Work by Contractor from the Contract Documents shall preclude Contractor from bringing any Claim or request for additional time or compensation on the basis of an alleged defect or error in the Contract Documents related to or arising, in any way, from that deviation, alteration, variation, addition, or omission. The Contractor further warrants that any alteration, variation, deletion, or omission fully complies with or exceeds all requirements of the Contract Documents and assumes all risk thereof.

5.3 Survival. The provisions of this Section shall (1) survive the expiration or termination of this Contract with respect to any event occurring prior to such expiration or termination, final payment hereunder, and any applicable statute of repose with respect to claims, fines, costs or damages brought or made against any Indemnified Party; (2) shall not be limited by RCW 4.16326(g); and (3) are in addition to any other rights or remedies which the City and/or any of the Indemnified Parties may have by law or under this Contract.

5.4 Offset. In the event of any claim or demand made against any Indemnified Party hereunder, the City may, in its sole discretion, reserve, retain or apply any monies due to the Contractor under the Contract or any other agreement or contract with the City for the purpose of resolving such claims; provided, however, that the City may, in the City's sole discretion, release such funds if the Contractor provides the City with adequate assurance of the protection of the City's and the other Indemnified Parties interests.

5.5 The Contractor shall ensure that each Subcontract includes a provision requiring each Subcontractor to indemnify and defend the City and the Indemnified Parties in the same manner, to the same extent, and for the same duration as Contractor agrees to indemnify and defend the City and the Indemnified Parties in this Section 5.

6. OWNERSHIP OF DOCUMENTS

All originals and copies of work product, including plans, sketches, layouts, designs, design specifications, records, files, computer disks, magnetic media, all finished or unfinished documents or material which may be produced or modified by Contractor while performing the Work, whether or not required to be furnished to the City, shall become the property of the City, shall be delivered to the City at its request, and may be used by the City without restriction.

7. PATENTS, COPYRIGHTS, AND RIGHTS IN DATA

7.1 Any patentable result or material suitable for copyright arising out of this Contract shall be owned by and made available to the City for public use, unless the City shall, in a specific case where it is legally permissible, determine that it is in the public interest that it not be so owned or available.

7.2 The Contractor agrees that the ownership of any plans, drawings, designs, specifications, computer programs, technical reports, operating manuals, calculations, notes and other work submitted or which is specified to be delivered under this Contract, whether or not complete (referred to in this subsection as "Subject Data"), is hereby irrevocably transferred and assigned to the City and shall be vested in the City or such other local, state or federal agency, if any, as may be provided by separate contract with the City. The Contractor shall execute and deliver such instruments and take such other action(s) as may be requested by the City to perfect or protect the City's rights to such Subject Data and work product, and to perfect the assignments and transfers contemplated in Sections 6 and 7.

7.3 All such Subject Data furnished by the Contractor pursuant to this Contract, other than documents exclusively for internal use by the City, shall carry such notations on the front cover or a title page (or in such case of maps, in the same block) as may be requested by the City. The Contractor shall also place their

endorsement on all Subject Data furnished by them. All such identification details shall be subject to approval by the City prior to printing.

7.4 The Contractor shall ensure that substantially the foregoing paragraphs in Sections 6 and 7 are included in each subcontract for the work on the Project.

8. GENERAL PROVISIONS

8.1 Entire Contract. The Contract Documents contain all of the agreements of the Parties with respect to any matter covered or mentioned in this Contract and no prior agreements or understandings pertaining to any such matters shall be effective for any purpose. In entering into this Contract, neither party has relied upon any statement, estimate, forecast, projection, representation, warranty, action or agreement of the other party except for those expressly contained in the Contract Documents.

8.2 Documents. The documents incorporated by reference, as if fully set forth in this Contract, are the Advertisement for Bids, the Instructions to Bidders and Checklists, the Contractor's Bid Proposal (including all forms and supplemental information listed on the Bidders Checklist), the Contract Documents (including Project Plans, Specifications, and all Appendices, Amendments, and Supplemental Reports & Information), the Contract Provisions (including all forms and supplemental information listed on the Contract Checklist), the version of the Washington State Standard Specifications for Road, Bridge, and Municipal Construction identified herein, and any other documents provided to bidders and/or referenced in or referred to by the Contract Documents.

8.3 Modification. No provisions of this Contract, including this provision, may be amended or added to except by agreement in writing signed by the Parties or their respective successors in interest in accordance with the Contract Documents.

8.4 Change Orders. In addition to its rights under the Contract Documents, the City may unilaterally issue a Change Order at any time making changes within the general scope of the Contract, without invalidating the Contract and without providing notice to sureties. The City's issuance of a unilateral Change Order shall not be construed as a waiver of any rights afforded the City, including its right to reject a prior protest or request for change or Claim due to untimeliness or the Contractor's failure to fully comply with the requirements of the Contract Documents, or to void the unilateral Change Order due to unilateral mistake, misrepresentation, or fraud.

8.5 Total Cost Method / Claims. In no event shall a Total Cost Method or a modified Total Cost Method be used by the Contractor to calculate any adjustments to the Contract price. For the purpose of this provision, any cost method, or variety of cost methods, using the difference between the actual cost of the Work and the Bid or Contract price of the Work to calculate any additional compensation or money owed to the Contractor shall be considered a Total Cost Method. In addition, the City shall not be responsible for, and the Contractor shall not be entitled to, any compensation for unallowable costs. Unallowable costs include, but are not limited to: (i) interest or attorneys' fees, except as mandated by statute; (ii) Claim preparation or filing costs; (iii) the costs of preparing notices or protests; (iv) lost profits, lost income, or lost earnings; (v) costs for idle equipment when such equipment is not at the Site, has not been employed in the Work, or is not scheduled to be used at the Site; (vi) claims consulting costs; (vii) expert fees and costs; (viii) loss of other business; and/or (ix) any other special, consequential, expectancy, incidental, or indirect damages incurred by the Contractor, Subcontractors, or suppliers.

8.6 Warranties and Guarantees. In addition to the requirements of the Contract Documents, the Contractor warrants that all portions of the Work that will be covered by a manufacturer's or supplier's guarantee or warranty shall be performed in such a manner so as to preserve all rights under such guarantees or warranties. If the City attempts to enforce a claim based upon a manufacturer's or supplier's guarantee or warranty and such manufacturer or supplier refuses to honor such guarantee or warranty based, in whole or in part, on a claim of defective installation by the Contractor or a Subcontractor, the Contractor shall be responsible for any resulting loss or damage, and repairs, incurred by the City as a result of the manufacturer's or supplier's refusal to honor such guarantee or warranty. This obligation survives termination of this Contract.

8.7 Full Force and Effect. Any provision of this Contract, which is declared invalid, void or illegal, shall in no way affect, impair, or invalidate any other provision hereof and such other provisions shall remain in full force and effect.

8.8 Assignment. The Contractor shall not transfer or assign, in whole or in part, any or all of its obligations and rights hereunder without the prior written consent of the City. In the event the City consents to any such assignment or transfer, such consent shall in no way release the Contractor from any of its obligations or liabilities under this Contract.

8.9 Successors In Interest. Subject to the preceding Subsection, this Contract shall be binding upon and inure to the benefit of the Parties' successors in interest, heirs and assigns.

8.10 Time Limitation and Venue. For the convenience of the parties to the Contract it is mutually agreed by the parties that any claims, causes of action, or disputes which the Contractor has against the City arising from the Contract shall be brought within the following time period: (i) 180 calendar days from the date of Substantial Completion for those claims, causes of action, or disputes arising prior to the date of Substantial Completion, and (ii) 180 calendar days from the date of Final Acceptance of the Contract by the City for those claims, causes of action, or dispute arising after the date of Substantial Completion. It is further agreed that the venue for any claim, cause of action, or dispute related to this Contract shall be King County, Washington, which shall have exclusive jurisdiction over any such case, controversy, or dispute. The parties understand and agree that the Contractor's failure to bring suit within the time period provided, shall be a complete bar to any such claims or causes of action. It is further mutually agreed by the parties that when any claims, causes of action, or disputes which the Contractor asserts against the City arising from the Contract are filed with the City or initiated in court, the Contractor shall permit the City to have timely access to any records deemed necessary by the City to assist in evaluating the claims, action, or dispute.

8.11 No Waiver. Failure of the City to declare any breach or default immediately upon occurrence thereof, or delay in taking any action in connection with, shall not waive such breach or default. Failure of the City to declare one breach or default does not act as a waiver of the City's right to declare another breach or default.

8.12 Sole Authority/Discretion/Judgment. Where the Contract Documents provide the City or its Engineer with "sole" authority, discretion, or judgment, such authority, discretion, or judgment shall be considered unconditional and absolute.

8.13 Governing Law. This Contract shall be made in and shall be governed by and interpreted in accordance with the laws of the State of Washington.

8.14 Authority. Each individual executing this Contract on behalf of the City and Contractor represents and warrants that such individuals are duly authorized to execute and deliver this Contract on behalf of the Contractor or City.

8.15 Engineer. The Engineer is the City's representative who directly supervises the engineering and administration of a construction Contract. The Engineer's authorities, duties, and responsibilities are limited to those specifically identified in the Contract Documents. Designation of an individual or entity as the Engineer for the Project is solely to identify the representative of the City as the entity to act as the Engineer as described in the Contract Documents. Using the term "engineer" does not imply that such entity or person is a licensed professional engineer or an engineering company and does not import any additional obligations upon the actions of the Engineer that may govern licensed professional engineers when performing engineering services.

The Engineer for this Project is designated as: John Mulkey, P.E.

8.16 Notices. Any notices required to be given to Contractor or to the Engineer shall be delivered to the Parties at the addresses set forth below. Any notices may be delivered personally to the addressee of the notice or may be deposited in the United States mail, postage prepaid, to the address set forth herein. Any notice so posted in the United States mail shall be deemed received three (3) days after the date of mailing.

CITY OF FEDERAL WAY

**21ST AVE S & S 320TH ST SIGNALIZATION
AND PEDESTRIAN IMPROVEMENTS
PROJECT #36225**

RFB-18

CFW RFB VERSION 2023-APR

***** PLAN CENTER COPY *** Official bid documents, plan holder's list, and addenda (if applicable) are available on [BXWA.com](https://www.bxwa.com)**

CONTRACTOR: Company
Attn: Individual to receive notices
Street Address
City, State, Zip

ENGINEER: City of Federal Way
Attn: John Mulkey, P.E.
33325 8th Ave S
Federal Way, WA 98003

8.17 Captions. The respective captions of the Sections of this Contract are inserted for convenience of reference only and shall not be deemed to modify or otherwise affect in any respect any of the provisions of this Contract.

8.18 Performance. Time is of the essence of this Contract and each and all of its provisions in which performance is a factor. Adherence to completion dates is essential to the Contractor's performance of this Contract.

8.19 Compliance with Ethics Code. If a violation of the City's Ethics Resolution No. 91-54, as amended, occurs as a result of the formation and/or performance of this Contract, this Contract may be rendered null and void, at the City's option.

9. PERFORMANCE/PAYMENT BOND

Pursuant to RCW 39.08.010, the Contractor's payment and performance bonds must be conditioned upon: (i) faithful performance of all of the provisions of the Contract, including warranty obligations; (ii) the payment of all laborers, mechanics, Subcontractors, and Suppliers, and all persons who supply such persons with provisions or supplies in carrying out the Work; and (iii) payment of any taxes, liabilities, increases, or penalties incurred on the Project under Titles 50, 51, and 82 RCW which may be due on (a) projects referred to in RCW 60.28.011(1)(b), and (b) projects for which the bond is conditioned on the payment of such taxes, liabilities, increases, or penalties. Contractor's obligations under this Contract shall not be limited to the dollar amount of the bond.

DATED the day and year set forth above.

CITY OF FEDERAL WAY:

CONTRACTOR:

Jim Ferrell, Mayor
33325 8th Avenue South
Federal Way, WA 98003-6325

Signature of Authorized Individual

ATTEST:

Printed Name of Authorized Individual

Stephanie Courtney, CMC, City Clerk

Street Address

APPROVED AS TO FORM:

City, State, Zip

J. Ryan Call, City Attorney

CITY OF FEDERAL WAY

**21ST AVE S & S 320TH ST SIGNALIZATION
AND PEDESTRIAN IMPROVEMENTS
PROJECT #36225**

RFB-19

CFW RFB VERSION 2023-APR

CERTIFICATE OF INSURANCE

*Contractor's Certificate of
Insurance to be inserted
here during Contract
Execution*

CITY OF FEDERAL WAY

**21ST AVE S & S 320TH ST SIGNALIZATION
AND PEDESTRIAN IMPROVEMENTS
PROJECT #36225**

RFB-23

CFW RFB VERSION 2023-APR

***** PLAN CENTER COPY *** Official bid documents, plan holder's list, and addenda (if applicable) are available on BXWA.com**

LOCAL OFFICE/AGENT OF SURETY:

Name

Street Address

City, State, Zip

Telephone

BOND NO.: _____

APPROVED AS TO FORM: _____
J. Ryan Call, City Attorney

CONTRACTOR'S RETAINAGE OPTION

IDENTIFICATION AND DESCRIPTION

Project Title: _____

RFB No: _____

Contractor: _____

GENERAL REQUIREMENTS

1. In accordance with applicable State Statutes, a contract retainage not to exceed five percent of the moneys earned by the contractor will be reserved by the City.
2. All investments selected are subject to City approval.
3. The final disposition of the contract retainage will be made in accordance with applicable State Statutes.

CONTRACTOR'S INSTRUCTIONS

Pursuant to RCW 60.28.011, I hereby notify the City of Federal Way of my instructions for the retainage withheld under the terms of this contract:

- Option 1:** Retained in a fund by the City of Federal Way. No interest will be paid to the contractor.
- Option 2:** Deposited in an interest bearing account in a bank, mutual savings bank, or savings and loan association. Interest paid to the contractor. Contractor shall have the bank (or other) execute a separate "City of Federal Way Retainage Bank Acceptance Agreement" upon contract award. The City will provide the agreement to the Contractor if this option is selected.
- Option 3:** Placed in escrow with a bank or trust company. Contractor shall execute, and have escrow account holder execute a separate "City of Federal Way Construction Retainage Escrow Agreement" upon contract award. The City will provide the agreement to the Contractor if this option is selected. All investments are subject to City approval. The cost of the investment program, and risk thereof, is to be borne entirely by the contractor.
- Option 4:** Contractor shall submit a "Retainage Bond" on City-provided form included in these Contract Documents.

Contractor Signature

Date

CITY OF FEDERAL WAY

21ST AVE S & S 320TH ST SIGNALIZATION
AND PEDESTRIAN IMPROVEMENTS
PROJECT #36225

RFB-26

CFW RFB VERSION 2023-APR

*** PLAN CENTER COPY *** Official bid documents, plan holder's list, and addenda (if applicable) are available on BXWA.com

RETAINAGE BOND TO CITY OF FEDERAL WAY
21ST AVE S & S 320TH STREET SIGNALIZATION AND PEDESTRIAN IMPROVEMENTS

KNOW ALL PERSONS BY THESE PRESENTS that we, the undersigned, _____, as principal ("Principal"), and _____, a Corporation organized and existing under the laws of the State of _____, as a surety Corporation, and qualified under the laws of the State of Washington to become surety upon bonds of Contractors with Municipal Corporations, as surety ("Surety"), are jointly and severally held and firmly bonded to the City of Federal Way ("City") in the penal sum of: _____ (\$ _____) for the payment of which sum we bind ourselves and our successors, heirs, administrators or personal representatives, as the case may be.

A. This obligation is entered into in pursuant to the statutes of the State of Washington and the ordinances, regulations, standards and policies of the City, as now existing or hereafter amended or adopted.

B. Pursuant to proper authorization, the Mayor is authorized to enter into a certain contract with the Principal, providing for the above-referenced Project, which contract is incorporated herein by this reference ("Contract"), and

C. Pursuant to State law, Chapter 60.28 RCW, the City is required to reserve from the monies earned by the Principal pursuant to the contract, a sum not to exceed five percent (5%), said sum to be retained by the City as a trust fund for the protection and payment of any person or persons, mechanic, subcontractor or material men who shall perform any labor upon such contract or the doing of such work, and all persons who shall supply such person or persons or subcontractors with provisions and supplies for the carrying on of such work, and the State with the respect to taxes imposed pursuant to Title 82 RCW which may be due from said Principal. Every person performing labor or furnishing supplies towards completion of said improvement or work shall have a lien on said monies so reserved, provided that such notice of the lien of such claimant shall be given in the manner and within the time provided in RCW 39.08.030 as now existing and in accordance with any amendments that may hereafter be provided thereto; and

D. State law further provides that with the consent of the City, the Principal may submit a bond for all or any portion of the amount of funds retained by the public body in a form acceptable to the public body conditioned upon such bond any proceeds therefrom being made subject to all claims and liens and in the same manner and priority as set forth retained percentages pursuant to Chapter 60.28 RCW; and

E. The Principal has accepted, or is about to accept, the Contract, and undertake to perform the work therein provided for in the manner and within the time set forth, for the amount of \$ _____; and

F. The City is prepared to release any required retainage money previously paid by the Principal prior to acceptance and successful operation and fulfillment of all other terms of said contract upon being indemnified by these presents,

NOW, THEREFORE, if the Principal shall perform all the provisions of the Contract in the manner and within the time period prescribed by the City, or within such extensions of time as may be granted under the Contract, and shall pay all laborers, mechanics, subcontractors and material men or women, and all persons who shall supply the Principal or subcontractors with provisions and supplies for the carrying on of said work, and if the Principal shall pay to the State all taxes imposed pursuant to Title 82 RCW which may be due from such Principal as a result of this contract then and in the event this obligation shall be void; but otherwise it shall be and remain in full force and effect.

And the Surety, for value received, hereby further stipulates and agrees that no change, extension of time, alteration or addition to the terms of the Contract or to the work to be performed thereunder or the specifications accompanying the same shall in any way affect its obligation on this bond, and it does hereby

CITY OF FEDERAL WAY

**21ST AVE S & S 320TH ST SIGNALIZATION
AND PEDESTRIAN IMPROVEMENTS
PROJECT #36225**

RFB-27

CFW RFB VERSION 2023-APR

waive notice of any change, extension of time, alterations or additions to the terms of the Contract or to the Work.

The Surety hereby agrees that modifications and changes may be made in the terms and provisions of the Contract without notice to Surety, and any such modifications or changes increasing the total amount to be paid the Principal shall automatically increase the obligation of the Surety on this Retainage Bond in a like amount, such increase, however, not to exceed twenty-five percent (25%) of the original amount of this bond without consent of the Surety.

Within forty-five (45) days of receiving notice that the Principal has defaulted on all or part of the terms of the Contract, the Surety shall make written commitment to the City that it will either: (a) cure the default itself within a reasonable time period, or (b) tender to the City, the amount necessary for the City to remedy the default, including legal fees incurred by the City, or (c) in the event that Surety's evaluation of the dispute is not complete or in the event the Surety disputes the City's claim of default, the Surety shall notify the City of its finding and its intent, if any, to interplead. The Surety shall then fulfill its obligations under this bond, according to the option it has elected. Should Surety elect option (a) to cure the default, the penal sum of the Bond shall be reduced in an amount equal to the costs actually incurred by the Surety in curing the default. If the Surety elects option (b), then upon completion of the necessary work, the City shall notify the Surety of its actual costs. The City shall return, without interest, any overpayment made by the Surety and the Surety shall pay to the City any actual costs which exceed the City estimate, limited to the bond amount. Should the Surety elect option (c), the Parties shall first complete participation in mediation, described in the below paragraph, prior to any interplead action.

In the event a dispute should arise between the Parties to this Bond with respect to the City's declaration of default by the Principal, the Parties agree to participate in at least four hours of mediation to resolve said dispute. The Parties shall proportionately share in the cost of the mediation. The mediation shall be administered by Judicial Dispute Resolution, LLC, 1425 Fourth Avenue, Suite 300, Seattle, Washington 98101. The Surety shall not interplead prior to completion of the mediation.

The parties have executed this instrument under their separate seals this ____ day of _____, 20____, the name and corporate seal of each corporate party hereto affixed, and these presents duly signed by its undersigned representatives pursuant to authority of its governing body.

CORPORATE SEAL:

PRINCIPAL:

By: _____

Title: _____

Address: _____

CORPORATE SEAL:

SURETY:

By: _____

*Attorney-in-Fact
(Attach Power of Attorney)*

Title: _____

CITY OF FEDERAL WAY

**21ST AVE S & S 320TH ST SIGNALIZATION
AND PEDESTRIAN IMPROVEMENTS
PROJECT #36225**

RFB-28

CFW RFB VERSION 2023-APR

Address: _____

CERTIFICATES AS TO CORPORATE SEAL

I hereby certify that I am the (Assistant) Secretary of the Corporation named as Principal in the within bond; that _____, who signed the said bond on behalf of the Principal, was _____ of said Corporation; that I know his or her signature thereto is genuine, and that said bond was duly signed, sealed, and attested for and in behalf of said Corporation by authority of its governing body.

Secretary of Principal

I hereby certify that I am the (Assistant) Secretary of the Corporation named as Surety in the within bond; that _____, who signed the said bond on behalf of the Surety, was _____ of the said Corporation; that I know his or her signature thereto is genuine, and that said bond was duly signed, sealed, and attested for and in behalf of said Corporation by authority of its governing body.

Secretary of Surety

APPROVED AS TO FORM:

J. Ryan Call, City Attorney

INTRODUCTION TO THE SPECIAL PROVISIONS

(December 10, 2020 APWA GSP)

The work on this project shall be accomplished in accordance with the *Standard Specifications for Road, Bridge and Municipal Construction*, 2023 edition, as issued by the Washington State Department of Transportation (WSDOT) and the American Public Works Association (APWA), Washington State Chapter (hereafter “Standard Specifications”). The Standard Specifications, as modified or supplemented by these Special Provisions, all of which are made a part of the Contract Documents, shall govern all of the Work.

These Special Provisions are made up of both General Special Provisions (GSPs) from various sources, which may have project-specific fill-ins; and project-specific Special Provisions. Each Provision either supplements, modifies, or replaces the comparable Standard Specification, or is a new Provision. The deletion, amendment, alteration, or addition to any subsection or portion of the Standard Specifications is meant to pertain only to that particular portion of the section, and in no way should it be interpreted that the balance of the section does not apply.

The project-specific Special Provisions are not labeled as such. The GSPs are labeled under the headers of each GSP, with the effective date of the GSP and its source. For example:

(March 8, 2013 APWA GSP)

(April 1, 2013 WSDOT GSP)

(April 12, 2018 CFW GSP)

*(***PROJECT-SPECIFIC SPECIAL PROVISION***)*

Also incorporated into the Contract Documents by reference are:

- *Manual on Uniform Traffic Control Devices for Streets and Highways*, currently adopted edition, with Washington State modifications, if any
- *Standard Plans for Road, Bridge and Municipal Construction*, WSDOT/APWA, current edition
- City of Federal Way Public Works Development Standards
- National Electric Code, current edition

Contractor shall obtain copies of these publications, at Contractor’s own expense.

CITY OF FEDERAL WAY

SP-1

**21ST AVE S & S 320TH STREET
SIGNALIZATION AND PEDESTRIAN
IMPROVEMENTS PROJECT
PROJECT #36225**

CFW SPECIAL PROVISIONS VER. 2023.06

***** PLAN CENTER COPY *** Official bid documents, plan holder's list, and addenda (if applicable) are available on BXWA.com**

DIVISION 1 GENERAL REQUIREMENTS

DESCRIPTION OF WORK

(March 13, 1995 WSDOT GSP)

This Contract provides for the improvement of the 21st Ave S at S 320th Street Signalization and Pedestrian Improvements and other work, all in accordance with the attached Contract Plans, these Contract Provisions, and the Standard Specifications.

1-01.3 Definitions

(January 19, 2022 APWA GSP)

Delete the heading **Completion Dates** and the three paragraphs that follow it, and replace them with the following:

Dates

Bid Opening Date

The date on which the Contracting Agency publicly opens and reads the Bids.

Award Date

The date of the formal decision of the Contracting Agency to accept the lowest responsible and responsive Bidder for the Work.

Contract Execution Date

The date the Contracting Agency officially binds the Agency to the Contract.

Notice to Proceed Date

The date stated in the Notice to Proceed on which the Contract time begins.

Substantial Completion Date

The day the Engineer determines the Contracting Agency has full and unrestricted use and benefit of the facilities, both from the operational and safety standpoint, any remaining traffic disruptions will be rare and brief, and only minor incidental work, replacement of temporary substitute facilities, plant establishment periods, or correction or repair remains for the Physical Completion of the total Contract.

Physical Completion Date

The day all of the Work is physically completed on the project. All documentation required by the Contract and required by law does not necessarily need to be furnished by the Contractor by this date.

Completion Date

The day all the Work specified in the Contract is completed and all the obligations of the Contractor under the contract are fulfilled by the Contractor. All documentation required by the Contract and required by law must be furnished by the Contractor before establishment of this date.

Final Acceptance Date

The date on which the Contracting Agency accepts the Work as complete.

Supplement this Section with the following:

All references in the Standard Specifications, Amendments, or WSDOT General Special Provisions, to the terms "Department of Transportation", "Washington State Transportation Commission", "Commission", "Secretary of Transportation", "Secretary", "Headquarters", and "State Treasurer" shall be revised to read "Contracting Agency."

CITY OF FEDERAL WAY

21ST AVE S & S 320TH STREET
SIGNALIZATION AND PEDESTRIAN
IMPROVEMENTS PROJECT
PROJECT #36225

SP-2

CFW SPECIAL PROVISIONS VER. 2023.06

All references to the terms “State” or “state” shall be revised to read “Contracting Agency” unless the reference is to an administrative agency of the State of Washington, a State statute or regulation, or the context reasonably indicates otherwise.

All references to “State Materials Laboratory” shall be revised to read “Contracting Agency designated location.”

All references to “final contract voucher certification” shall be interpreted to mean the Contracting Agency form(s) by which final payment is authorized, and final completion and acceptance granted.

Additive

A supplemental unit of work or group of bid items, identified separately in the Bid Proposal, which may, at the discretion of the Contracting Agency, be awarded in addition to the base bid.

Alternate

One of two or more units of work or groups of bid items, identified separately in the Bid Proposal, from which the Contracting Agency may make a choice between different methods or material of construction for performing the same work.

Business Day

A business day is any day from Monday through Friday except holidays as listed in Section 1-08.5.

Contract Bond

The definition in the Standard Specifications for “Contract Bond” applies to whatever bond form(s) are required by the Contract Documents, which may be a combination of a Payment Bond and a Performance Bond.

Contract Documents

See definition for “Contract.”

Contract Time

The period of time established by the terms and conditions of the Contract within which the Work must be physically completed.

Notice of Award

The written notice from the Contracting Agency to the successful Bidder signifying the Contracting Agency’s acceptance of the Bid Proposal.

Notice to Proceed

The written notice from the Contracting Agency or Engineer to the Contractor authorizing and directing the Contractor to proceed with the Work and establishing the date on which the Contract time begins.

Traffic

CITY OF FEDERAL WAY

**21ST AVE S & S 320TH STREET
SIGNALIZATION AND PEDESTRIAN
IMPROVEMENTS PROJECT
PROJECT #36225**

SP-3

CFW SPECIAL PROVISIONS VER. 2023.06

Both vehicular and non-vehicular traffic, such as pedestrians, bicyclists, wheelchairs, and equestrian traffic.

1-02 BID PROCEDURES AND CONDITIONS

1-02.1 Prequalification of Bidders

Delete this Section and replace it with the following:

1-02.1 Qualifications of Bidder

(January 24, 2011 APWA GSP)

Before award of a public works Contract, a bidder must meet at least the minimum qualifications of RCW 39.04.350(1) to be considered a responsible bidder and qualified to be awarded a public works project.

1-02.2 Plans and Specifications

(June 27, 2011 APWA GSP)

Delete this section and replace it with the following:

Information as to where Bid Documents can be obtained or reviewed can be found in the Call for Bids (Advertisement for Bids) for the work.

After award of the Contract, Plans and specifications will be issued to the Contractor at no cost as detailed below:

To Prime Contractor	No. of Sets	Basis of Distribution
Reduced Plans (11" x 17")	1	Furnished automatically upon award.
Contract Provisions	1	Furnished automatically upon award.
Large Plans (e.g., 22" x 34")	1	Furnished only upon request.

Additional Plans and Contract Provisions may be obtained by the Contractor from the source stated in the Call for Bids, at the Contractor's own expense.

1-02.4 Examination of Plans, Specifications, and Site Work

(June 27, 2011 APWA GSP)

1-02.4(1) General

(December 30, 2022 APWA GSP, Option B)

The first sentence of the ninth paragraph, beginning with "Prospective Bidder desiring...", is revised to read:

Prospective Bidders desiring an explanation or interpretation of the Bid Documents, shall request the explanation or interpretation in writing by close of business three (3) business days preceding the bid opening to allow a written reply to reach all prospective Bidders before the submission of their Bids.

1-02.4(2) Subsurface Information

(January 19, 2022 APWA GSP)

The third and fourth sentences in the first paragraph are revised to read:

The Summary of Geotechnical Conditions and the boring logs, if and when included as an appendix to the Special Provisions, shall be considered as part of

CITY OF FEDERAL WAY

SP-4

21ST AVE S & S 320TH STREET
SIGNALIZATION AND PEDESTRIAN
IMPROVEMENTS PROJECT
PROJECT #36225

the Contract. The boring logs and associated data, if and when included as an appendix to the Special Provisions, shall be considered as part of the Contract.

1-02.5 Proposal Forms

(July 31, 2017 APWA GSP)

Delete this section and replace it with the following:

The Proposal Form will identify the project and its location and describe the work. It will also list estimated quantities, units of measurement, the items of work, and the materials to be furnished at the unit bid prices. The bidder shall complete spaces on the proposal form that call for, but are not limited to, unit prices; extensions; summations; the total bid amount; signatures; date; and, where applicable, retail sales taxes and acknowledgment of addenda; the bidder's name, address, telephone number, and signature; the bidder's UBDE/DBE/M/WBE commitment, if applicable; a State of Washington Contractor's Registration Number; and a Business License Number, if applicable. Bids shall be completed by typing or shall be printed in ink by hand, preferably in black ink. The required certifications are included as part of the Proposal Form.

The Contracting Agency reserves the right to arrange the proposal forms with alternates and additives, if such be to the advantage of the Contracting Agency. The bidder shall bid on all alternates and additives set forth in the Proposal Form unless otherwise specified.

1-02.6 Preparation of Proposal

(December 10, 2020 APWA GSP, OPTION B)

Supplement the second paragraph with the following:

4. If a minimum bid amount has been established for any item, the unit or lump sum price must equal or exceed the minimum amount stated.
5. Any correction to a bid made by interlineation, alteration, or erasure, shall be initialed by the signer of the bid.

Delete the last two paragraphs, and replace them with the following:

The Bidder shall submit with their Bid a completed Contractor Certification Wage Law Compliance form, provided by the Contracting Agency. Failure to return this certification as part of the Bid Proposal package will make this Bid Nonresponsive and ineligible for Award. A Contractor Certification of Wage Law Compliance form is included in the Proposal Forms.

The Bidder shall make no stipulation on the Bid Form, nor qualify the bid in any manner.

A bid by a corporation shall be executed in the corporate name, by the president or a vice president (or other corporate officer accompanied by evidence of authority to sign).

A bid by a partnership shall be executed in the partnership name, and signed by a partner. A copy of the partnership agreement shall be submitted with the Bid Form if any UDBE requirements are to be satisfied through such an agreement.

CITY OF FEDERAL WAY

SP-5

**21ST AVE S & S 320TH STREET
SIGNALIZATION AND PEDESTRIAN
IMPROVEMENTS PROJECT
PROJECT #36225**

CFW SPECIAL PROVISIONS VER. 2023.06

A bid by a joint venture shall be executed in the joint venture name and signed by a member of the joint venture. A copy of the joint venture agreement shall be submitted with the Bid Form if any UDBE requirements are to be satisfied through such an agreement.

(June 4, 2020 WSDOT GSP, OPTION 9)

Item number 1 in the fifth paragraph of Section 1-02.6 is revised to read:

1. Subcontractors who will perform the work of structural steel installation, rebar installation, heating, ventilation, air conditioning and plumbing as described in RCW 18.106 and electrical as described in RCW 19.28, and

Add the following new section:

1-02.6(1) Recycled Materials Proposal

(January 4, 2016 APWA GSP)

The Bidder shall submit with the Bid, its proposal for incorporating recycled materials into the project, using the form provided in the Contract Provisions.

1-02.7 Bid Deposit

(March 8, 2013 APWA GSP)

Supplement this section with the following:

Bid bonds shall contain the following:

1. Contracting Agency-assigned number for the project;
2. Name of the project;
3. The Contracting Agency named as obligee;
4. The amount of the bid bond stated either as a dollar figure or as a percentage which represents five percent of the maximum bid amount that could be awarded;
5. Signature of the bidder's officer empowered to sign official statements. The signature of the person authorized to submit the bid should agree with the signature on the bond, and the title of the person must accompany the said signature;
6. The signature of the surety's officer empowered to sign the bond and the power of attorney.

If so stated in the Contract Provisions, bidder must use the bond form included in the Contract Provisions.

If so stated in the Contract Provisions, cash will not be accepted for a bid deposit.

1-02.10 Withdrawing, Revising, or Supplementing Proposal

(July 23, 2015 APWA GSP)

Delete this section, and replace it with the following:

After submitting a physical Bid Proposal to the Contracting Agency, the Bidder may withdraw, revise, or supplement it if:

1. The Bidder submits a written request signed by an authorized person and physically delivers it to the place designated for receipt of Bid Proposals, and

CITY OF FEDERAL WAY

**21ST AVE S & S 320TH STREET
SIGNALIZATION AND PEDESTRIAN
IMPROVEMENTS PROJECT
PROJECT #36225**

SP-6

CFW SPECIAL PROVISIONS VER. 2023.06

2. The Contracting Agency receives the request before the time set for receipt of Bid Proposals, and
3. The revised or supplemented Bid Proposal (if any) is received by the Contracting Agency before the time set for receipt of Bid Proposals.

If the Bidder's request to withdraw, revise, or supplement its Bid Proposal is received before the time set for receipt of Bid Proposals, the Contracting Agency will return the unopened Proposal package to the Bidder. The Bidder must then submit the revised or supplemented package in its entirety. If the Bidder does not submit a revised or supplemented package, then its bid shall be considered withdrawn.

Late revised or supplemented Bid Proposals or late withdrawal requests will be date recorded by the Contracting Agency and returned unopened. Mailed, emailed, or faxed requests to withdraw, revise, or supplement a Bid Proposal are not acceptable.

1-02.13 Irregular Proposals
(December 30, 2022 APWA GSP)

Delete this section and replace it with the following:

1. A Proposal will be considered irregular and will be rejected if:
 - a. The Bidder is not prequalified when so required;
 - b. The authorized Proposal form furnished by the Contracting Agency is not used or is altered;
 - c. The completed Proposal form contains any unauthorized additions, deletions, alternate Bids, or conditions;
 - d. The Bidder adds provisions reserving the right to reject or accept the award, or enter into the Contract;
 - e. A price per unit cannot be determined from the Bid Proposal;
 - f. The Proposal form is not properly executed;
 - g. The Bidder fails to submit or properly complete a subcontractor list (WSDOT Form 271-015), if applicable, as required in Section 1-02.6;
 - h. The Bidder fails to submit or properly complete an Disadvantaged Business Enterprise Certification (WSDOT Form 272-056), if applicable, as required in Section 1-02.6;
 - i. The Bidder fails to submit Written Confirmations (WSDOT Form 422-031) from each DBE firm listed on the Bidder's completed DBE Utilization Certification that they are in agreement with the bidder's DBE participation commitment, if applicable, as required in Section 1-02.6, or if the written confirmation that is submitted fails to meet the requirements of the Special Provisions;
 - j. The Bidder fails to submit DBE Good Faith Effort documentation, if applicable, as required in Section 1-02.6, or if the documentation that is submitted fails to demonstrate that a Good Faith Effort to meet the Condition of Award was made;
 - k. The Bidder fails to submit a DBE Bid Item Breakdown (WSDOT Form 272-054), if applicable, as required in Section 1-02.6, or if the documentation that is submitted fails to meet the requirements of the Special Provisions;
 - l. The Bidder fails to submit DBE Trucking Credit Forms, if applicable, as required in Section 1-02.6, or if the documentation that is submitted fails to meet the requirements of the Special Provisions;

CITY OF FEDERAL WAY

SP-7

**21ST AVE S & S 320TH STREET
SIGNALIZATION AND PEDESTRIAN
IMPROVEMENTS PROJECT
PROJECT #36225**

CFW SPECIAL PROVISIONS VER. 2023.06

- m. The Bid Proposal does not constitute a definite and unqualified offer to meet the material terms of the Bid invitation; or
 - n. More than one Proposal is submitted for the same project from a Bidder under the same or different names.
2. A Proposal may be considered irregular and may be rejected if:
- a. The Proposal does not include a unit price for every Bid item;
 - b. Any of the unit prices are excessively unbalanced (either above or below the amount of a reasonable Bid) to the potential detriment of the Contracting Agency;
 - c. Receipt of Addenda is not acknowledged;
 - d. A member of a joint venture or partnership and the joint venture or partnership submit Proposals for the same project (in such an instance, both Bids may be rejected); or
 - e. If Proposal form entries are not made in ink.

1-02.14 Disqualification of Bidders
(May 17, 2018 APWA GSP, OPTION B)

Delete this section and replace it with the following:

A Bidder will be deemed not responsible if the Bidder does not meet the mandatory bidder responsibility criteria in RCW 39.04.350(1), as amended; or does not meet Supplemental Criteria 1-7 listed in this Section.

Contracting Agency will verify that the Bidder meets the mandatory bidder responsibility criteria in RCW 39.04.350(1), and Supplemental Criteria 1-2. Evidence that the Bidder meets Supplemental Criteria 3-7 shall be provided by the Bidder as stated later in this Section.

1. **Delinquent State Taxes**

- A. Criterion: The Bidder shall not owe delinquent taxes to the Washington State Department of Revenue without a payment plan approved by the Department of Revenue.
- B. Documentation: The Bidder, if and when required as detailed below, shall sign a statement (on a form to be provided by the Contracting Agency) that the Bidder does not owe delinquent taxes to the Washington State Department of Revenue, or if delinquent taxes are owed to the Washington State Department of Revenue, the Bidder must submit a written payment plan approved by the Department of Revenue, to the Contracting Agency by the deadline listed below.

2. **Federal Debarment**

- A. Criterion: The Bidder shall not currently be debarred or suspended by the Federal government.
- B. Documentation: The Bidder shall not be listed as having an “active exclusion” on the U.S. government’s “System for Award Management” database (www.sam.gov).

3. **Subcontractor Responsibility**

CITY OF FEDERAL WAY

21ST AVE S & S 320TH STREET
 SIGNALIZATION AND PEDESTRIAN
 IMPROVEMENTS PROJECT
 PROJECT #36225

SP-8

- A. Criterion: The Bidder's standard subcontract form shall include the subcontractor responsibility language required by RCW 39.06.020, and the Bidder shall have an established procedure which it utilizes to validate the responsibility of each of its subcontractors. The Bidder's subcontract form shall also include a requirement that each of its subcontractors shall have and document a similar procedure to determine whether the sub-tier subcontractors with whom it contracts are also "responsible" subcontractors as defined by RCW 39.06.020.
- B. Documentation: The Bidder, if and when required as detailed below, shall submit a copy of its standard subcontract form for review by the Contracting Agency, and a written description of its procedure for validating the responsibility of subcontractors with which it contracts.
4. **Claims Against Retainage and Bonds**
- A. Criterion: The Bidder shall not have a record of excessive claims filed against the retainage or payment bonds for public works projects in the three years prior to the bid submittal date, that demonstrate a lack of effective management by the Bidder of making timely and appropriate payments to its subcontractors, suppliers, and workers, unless there are extenuating circumstances and such circumstances are deemed acceptable to the Contracting Agency.
- B. Documentation: The Bidder, if and when required as detailed below, shall submit a list of the public works projects completed in the three years prior to the bid submittal date that have had claims against retainage and bonds and include for each project the following information:
- Name of project
 - The owner and contact information for the owner;
 - A list of claims filed against the retainage and/or payment bond for any of the projects listed;
 - A written explanation of the circumstances surrounding each claim and the ultimate resolution of the claim.
5. **Public Bidding Crime**
- A. Criterion: The Bidder and/or its owners shall not have been convicted of a crime involving bidding on a public works contract in the five years prior to the bid submittal date.
- B. Documentation: The Bidder, if and when required as detailed below, shall sign a statement (on a form to be provided by the Contracting Agency) that the Bidder and/or its owners have not been convicted of a crime involving bidding on a public works contract.
6. **Termination for Cause / Termination for Default**
- A. Criterion: The Bidder shall not have had any public works contract terminated for cause or terminated for default by a government agency in the five years prior to the bid submittal date, unless there are extenuating circumstances and such circumstances are deemed acceptable to the Contracting Agency.

CITY OF FEDERAL WAY

21ST AVE S & S 320TH STREET
SIGNALIZATION AND PEDESTRIAN
IMPROVEMENTS PROJECT
PROJECT #36225

SP-9

CFW SPECIAL PROVISIONS VER. 2023.06

- B. Documentation: The Bidder, if and when required as detailed below, shall sign a statement (on a form to be provided by the Contracting Agency) that the Bidder has not had any public works contract terminated for cause or terminated for default by a government agency in the five years prior to the bid submittal date; or if Bidder was terminated, describe the circumstances. .

7. **Lawsuits**

- A. Criterion: The Bidder shall not have lawsuits with judgments entered against the Bidder in the five years prior to the bid submittal date that demonstrate a pattern of failing to meet the terms of contracts, unless there are extenuating circumstances and such circumstances are deemed acceptable to the Contracting Agency
- B. Documentation: The Bidder, if and when required as detailed below, shall sign a statement (on a form to be provided by the Contracting Agency) that the Bidder has not had any lawsuits with judgments entered against the Bidder in the five years prior to the bid submittal date that demonstrate a pattern of failing to meet the terms of contracts, or shall submit a list of all lawsuits with judgments entered against the Bidder in the five years prior to the bid submittal date, along with a written explanation of the circumstances surrounding each such lawsuit. The Contracting Agency shall evaluate these explanations to determine whether the lawsuits demonstrate a pattern of failing to meet of terms of construction related contracts

As evidence that the Bidder meets the Supplemental Criteria stated above, the apparent low Bidder must submit to the Contracting Agency by 12:00 P.M. (noon) of the second business day following the bid submittal deadline, a written statement verifying that the Bidder meets the supplemental criteria together with supporting documentation (sufficient in the sole judgment of the Contracting Agency) demonstrating compliance with the Supplemental Criteria. The Contracting Agency reserves the right to request further documentation as needed from the low Bidder and documentation from other Bidders as well to assess Bidder responsibility and compliance with all bidder responsibility criteria. The Contracting Agency also reserves the right to obtain information from third-parties and independent sources of information concerning a Bidder's compliance with the mandatory and supplemental criteria, and to use that information in their evaluation. The Contracting Agency may consider mitigating factors in determining whether the Bidder complies with the requirements of the supplemental criteria.

The basis for evaluation of Bidder compliance with these mandatory and supplemental criteria shall include any documents or facts obtained by Contracting Agency (whether from the Bidder or third parties) including but not limited to: (i) financial, historical, or operational data from the Bidder; (ii) information obtained directly by the Contracting Agency from others for whom the Bidder has worked, or other public agencies or private enterprises; and (iii) any additional information obtained by the Contracting Agency which is believed to be relevant to the matter.

If the Contracting Agency determines the Bidder does not meet the bidder responsibility criteria above and is therefore not a responsible Bidder, the Contracting Agency shall notify

CITY OF FEDERAL WAY

**21ST AVE S & S 320TH STREET
SIGNALIZATION AND PEDESTRIAN
IMPROVEMENTS PROJECT
PROJECT #36225**

SP-10

CFW SPECIAL PROVISIONS VER. 2023.06

the Bidder in writing, with the reasons for its determination. If the Bidder disagrees with this determination, it may appeal the determination within two (2) business days of the Contracting Agency's determination by presenting its appeal and any additional information to the Contracting Agency. The Contracting Agency will consider the appeal and any additional information before issuing its final determination. If the final determination affirms that the Bidder is not responsible, the Contracting Agency will not execute a contract with any other Bidder until at least two business days after the Bidder determined to be not responsible has received the Contracting Agency's final determination.

Request to Change Supplemental Bidder Responsibility Criteria Prior To Bid: Bidders with concerns about the relevancy or restrictiveness of the Supplemental Bidder Responsibility Criteria may make or submit requests to the Contracting Agency to modify the criteria. Such requests shall be in writing, describe the nature of the concerns, and propose specific modifications to the criteria. Bidders shall submit such requests to the Contracting Agency no later than five (5) business days prior to the bid submittal deadline and address the request to the Project Engineer or such other person designated by the Contracting Agency in the Bid Documents.

1-03 AWARD AND EXECUTION OF CONTRACT

1-03.1 Consideration of Bids

(December 30, 2022 APWA GSP)

Revise the first paragraph to read:

After opening and reading proposals, the Contracting Agency will check them for correctness of extensions of the prices per unit and the total price. If a discrepancy exists between the price per unit and the extended amount of any bid item, the price per unit will control. If a minimum bid amount has been established for any item and the bidder's unit or lump sum price is less than the minimum specified amount, the Contracting Agency will unilaterally revise the unit or lump sum price, to the minimum specified amount and recalculate the extension. The total of extensions, corrected where necessary, including sales taxes where applicable and such additives and/or alternates as selected by the Contracting Agency, will be used by the Contracting Agency for award purposes and to fix the Awarded Contract Price amount and the amount of the contract bond.

1-03.1(1) Identical Bid Totals

(December 30, 2022 APWA GSP)

Revise this section to read:

After opening Bids, if two or more lowest responsive Bid totals are exactly equal, then the tie-breaker will be the Bidder with an equal lowest bid, that proposed to use the highest percentage of recycled materials in the Project, per the form submitted with the Bid Proposal. If those percentages are also exactly equal, then the tie-breaker will be determined by drawing as follows: Two or more slips of paper will be marked as follows: one marked "Winner" and the other(s) marked "unsuccessful." The slips will be folded to make the marking unseen. The slips will be placed inside a box. One authorized representative of each Bidder shall draw a slip from the box. Bidders shall draw in alphabetic order by the name of the firm as registered with the Washington State Department of Licensing. The slips shall be unfolded and the firm with the slip marked "Winner" will be determined to be the successful Bidder and eligible for Award of the

CITY OF FEDERAL WAY

SP-11

**21ST AVE S & S 320TH STREET
SIGNALIZATION AND PEDESTRIAN
IMPROVEMENTS PROJECT
PROJECT #36225**

Contract. Only those Bidders who submitted a Bid total that is exactly equal to the lowest responsive Bid, and with a proposed recycled materials percentage that is exactly equal to the highest proposed recycled materials amount, are eligible to draw.

1-03.3 Execution of Contract
(January 19, 2022 APWA GSP)

Revise this section to read:

Within 3 calendar days of Award date (not including Saturdays, Sundays, and Holidays), the successful Bidder shall provide the information necessary to execute the Contract to the Contracting Agency. The Bidder shall send the contact information, including the full name, email address, and phone number, for the authorized signer and bonding agent to the Contracting Agency.

Copies of the Contract Provisions, including the unsigned Form of Contract, will be available for signature by the successful bidder on the first business day following award. The number of copies to be executed by the Contractor will be determined by the Contracting Agency.

Within 10 calendar days after the award date, the successful bidder shall return the signed Contracting Agency-prepared contract, an insurance certification as required by Section 1-07.18, and a satisfactory bond as required by law and Section 1-03.4, the Transfer of Coverage form for the Construction Stormwater General Permit with sections I, III, and VIII completed when provided. Before execution of the contract by the Contracting Agency, the successful bidder shall provide any pre-award information the Contracting Agency may require under Section 1-02.15.

Until the Contracting Agency executes a contract, no proposal shall bind the Contracting Agency nor shall any work begin within the project limits or within Contracting Agency-furnished sites. The Contractor shall bear all risks for any work begun outside such areas and for any materials ordered before the contract is executed by the Contracting Agency.

If the bidder experiences circumstances beyond their control that prevents return of the contract documents within the calendar days after the award date stated above, the Contracting Agency may grant up to a maximum of 5 additional calendar days for return of the documents, provided the Contracting Agency deems the circumstances warrant it.

1-03.4 Contract Bond
(July 23, 2015 APWA GSP)

Delete the first paragraph and replace it with the following:

The successful bidder shall provide executed payment and performance bond(s) for the full contract amount. The bond may be a combined payment and performance bond; or be separate payment and performance bonds. In the case of separate payment and performance bonds, each shall be for the full contract amount. The bond(s) shall:

1. Be on Contracting Agency-furnished form(s);
2. Be signed by an approved surety (or sureties) that:
 - a. Is registered with the Washington State Insurance Commissioner, and

CITY OF FEDERAL WAY

**21ST AVE S & S 320TH STREET
SIGNALIZATION AND PEDESTRIAN
IMPROVEMENTS PROJECT
PROJECT #36225**

SP-12

CFW SPECIAL PROVISIONS VER. 2023.06

- b. Appears on the current Authorized Insurance List in the State of Washington published by the Office of the Insurance Commissioner,
3. Guarantee that the Contractor will perform and comply with all obligations, duties, and conditions under the Contract, including but not limited to the duty and obligation to indemnify, defend, and protect the Contracting Agency against all losses and claims related directly or indirectly from any failure:
 - a. Of the Contractor (or any of the employees, subcontractors, or lower tier subcontractors of the Contractor) to faithfully perform and comply with all contract obligations, conditions, and duties, or
 - b. Of the Contractor (or the subcontractors or lower tier subcontractors of the Contractor) to pay all laborers, mechanics, subcontractors, lower tier subcontractors, material person, or any other person who provides supplies or provisions for carrying out the work;
4. Be conditioned upon the payment of taxes, increases, and penalties incurred on the project under titles 50, 51, and 82 RCW; and
5. Be accompanied by a power of attorney for the Surety's officer empowered to sign the bond; and
6. Be signed by an officer of the Contractor empowered to sign official statements (sole proprietor or partner). If the Contractor is a corporation, the bond(s) must be signed by the president or vice president, unless accompanied by written proof of the authority of the individual signing the bond(s) to bind the corporation (i.e., corporate resolution, power of attorney, or a letter to such effect signed by the president or vice president).

1-03.7 Judicial Review
(December 30, 2022 APWA GSP)

Revise this section to read:

All decision made by the Contracting Agency regarding the Award and execution of the Contract or Bid rejection shall be conclusive subject to the scope of judicial review permitted under Washington Law. Such review, if any, shall be timely filed in the Superior Court of the county where the Contracting Agency headquarters is located, provided that where an action is asserted against a county, RCW 36.01.050 shall control venue and jurisdiction.

1-04 SCOPE OF THE WORK

1-04.2 Coordination of Contract Documents, Plans, Special Provisions, Specifications, and Addenda

(January 8, 2021 CFW GSP)

Revise the second paragraph to read:

Any inconsistency in the parts of the contract shall be resolved by following this order of precedence (e.g., 1 presiding over 2, 2 over 3, 3 over 4, and so forth):

1. Contract,

CITY OF FEDERAL WAY

**21ST AVE S & S 320TH STREET
 SIGNALIZATION AND PEDESTRIAN
 IMPROVEMENTS PROJECT
 PROJECT #36225**

SP-13

2. Change Orders, with those of a later date taking precedence of those of an earlier date,
3. Addenda, with those of a later date taking precedence of those of an earlier date,
4. Proposal Form,
5. Special Provisions,
6. Contract Plans,
7. Standard Specifications,
8. Contracting Agency's Standard Plans or Details (if any), and
9. WSDOT Standard Plans for Road, Bridge, and Municipal Construction.

1-04.4 Changes

(January 19, 2022 APWA GSP)

The first two sentences of the last paragraph of Section 1-04.4 are deleted.

1-05 CONTROL OF WORK

1-05.4 Conformity With and Deviations from Plans and Stakes

(January 13, 2021 WSDOT GSP, OPTION 2)

Section 1-05.4 is supplemented with the following:

Contractor Surveying – Roadway

The Contracting Agency has provided primary survey control in the Plans.

The Contractor shall be responsible for setting, maintaining, and resetting all alignment stakes, slope stakes, and grades necessary for the construction of the roadbed, drainage, surfacing, paving, channelization and pavement marking, illumination and signals, guardrails and barriers, and signing. Except for the survey control data to be furnished by the Contracting Agency, calculations, surveying, and measuring required for setting and maintaining the necessary lines and grades shall be the Contractor's responsibility.

The Contractor shall inform the Engineer when monuments are discovered that were not identified in the Plans and construction activity may disturb or damage the monuments. All monuments noted on the plans "DO NOT DISTURB" shall be protected throughout the length of the project or be replaced at the Contractors expense.

Detailed survey records shall be maintained, including a description of the work performed on each shift, the methods utilized, and the control points used. The record shall be adequate to allow the survey to be reproduced. A copy of each day's record shall be provided to the Engineer within three working days after the end of the shift.

The meaning of words and terms used in this provision shall be as listed in "Definitions of Surveying and Associated Terms" current edition, published by the American Congress on Surveying and Mapping and the American Society of Civil Engineers.

The survey work shall include but not be limited to the following:

CITY OF FEDERAL WAY

SP-14

**21ST AVE S & S 320TH STREET
SIGNALIZATION AND PEDESTRIAN
IMPROVEMENTS PROJECT
PROJECT #36225**

1. Verify the primary horizontal and vertical control furnished by the Contracting Agency, and expand into secondary control by adding stakes and hubs as well as additional survey control needed for the project. Provide descriptions of secondary control to the Contracting Agency. The description shall include coordinates and elevations of all secondary control points.
2. Establish, the centerlines of all alignments, by placing hubs, stakes, or marks on centerline or on offsets to centerline at all curve points (PCs, PTs, and PIs) and at points on the alignments spaced no further than 50 feet.
3. Establish clearing limits, placing stakes at all angle points and at intermediate points not more than 50 feet apart. The clearing and grubbing limits shall be 5 feet beyond the toe of a fill and 10 feet beyond the top of a cut unless otherwise shown in the Plans.
4. Establish grading limits, placing slope stakes at centerline increments not more than 50 feet apart. Establish offset reference to all slope stakes. If Global Positioning Satellite (GPS) Machine Controls are used to provide grade control, then slope stakes may be omitted at the discretion of the Contractor
5. Establish the horizontal and vertical location of all drainage features, placing offset stakes to all drainage structures and to pipes at a horizontal interval not greater than 25 feet.
6. Establish roadbed and surfacing elevations by placing stakes at the top of subgrade and at the top of each course of surfacing. Subgrade and surfacing stakes shall be set at horizontal intervals not greater than 50 feet in tangent sections, 25 feet in curve sections with a radius less than 300 feet, and at 10-foot intervals in intersection radii with a radius less than 10 feet. Transversely, stakes shall be placed at all locations where the roadway slope changes and at additional points such that the transverse spacing of stakes is not more than 12 feet. If GPS Machine Controls are used to provide grade control, then roadbed and surfacing stakes may be omitted at the discretion of the Contractor.
7. Establish intermediate elevation benchmarks as needed to check work throughout the project.
8. Provide references for paving pins at 25-foot intervals or provide simultaneous surveying to establish location and elevation of paving pins as they are being placed.
9. For all other types of construction included in this provision, (including but not limited to channelization and pavement marking, illumination and signals, guardrails and barriers, and signing) provide staking and layout as necessary to adequately locate, construct, and check the specific construction activity.
10. Contractor shall determine if changes are needed to the profiles or roadway sections shown in the Contract Plans in order to achieve proper smoothness and

CITY OF FEDERAL WAY

**21ST AVE S & S 320TH STREET
SIGNALIZATION AND PEDESTRIAN
IMPROVEMENTS PROJECT
PROJECT #36225**

SP-15

CFW SPECIAL PROVISIONS VER. 2023.06

drainage where matching into existing features, such as a smooth transition from new pavement to existing pavement. The Contractor shall submit these changes to the Engineer for review and approval 10 days prior to the beginning of work.

The Contractor shall provide the Contracting Agency copies of any calculations and staking data when requested by the Engineer.

The Contractor shall ensure a surveying accuracy within the following tolerances:

	<u>Vertical</u>	<u>Horizontal</u>
Slope stakes	±0.10 feet	±0.10 feet
Subgrade grade stakes set 0.04 feet below grade	±0.01 feet	±0.5 feet (parallel to alignment) ±0.1 feet (normal to alignment)
Stationing on roadway	N/A	±0.1 feet
Alignment on roadway	N/A	±0.04 feet
Surfacing grade stakes	±0.01 feet	±0.5 feet (parallel to alignment) ±0.1 feet (normal to alignment)
Roadway paving pins for surfacing or paving	±0.01 feet	±0.2 feet (parallel to alignment) ±0.1 feet (normal to alignment)

The Contracting Agency may spot-check the Contractor's surveying. These spot-checks will not change the requirements for normal checking by the Contractor.

When staking roadway alignment and stationing, the Contractor shall perform independent checks from different secondary control to ensure that the points staked are within the specified survey accuracy tolerances.

The Contractor shall calculate coordinates for the alignment. The Contracting Agency will verify these coordinates prior to issuing approval to the Contractor for commencing with the work. The Contracting Agency will require up to seven calendar days from the date the data is received.

Contract work to be performed using contractor-provided stakes shall not begin until the stakes are approved by the Contracting Agency. Such approval shall not relieve the Contractor of responsibility for the accuracy of the stakes.

CITY OF FEDERAL WAY

**21ST AVE S & S 320TH STREET
SIGNALIZATION AND PEDESTRIAN
IMPROVEMENTS PROJECT
PROJECT #36225**

SP-16

CFW SPECIAL PROVISIONS VER. 2023.06

Stakes shall be marked in accordance with Standard Plan A10.10. When stakes are needed that are not described in the Plans, then those stakes shall be marked, at no additional cost to the Contracting Agency as ordered by the Engineer.

Payment

Payment will be made for the following bid item when included in the proposal:

"Roadway Surveying", lump sum.

The lump sum contract price for "Roadway Surveying" shall be full pay for all labor, equipment, materials, and supervision utilized to perform the Work specified, including any resurveying, checking, correction of errors, replacement of missing or damaged stakes, and coordination efforts.

(March 9, 2023, WSDOT GSP, OPTION 4)

Section 1-05.4 is supplemented with the following:

Contractor Surveying - ADA Features

ADA Feature Staking Requirements

The Contractor shall be responsible for setting, maintaining, and resetting all alignment stakes, and grades necessary for the construction of the ADA features. Calculations, surveying, and measuring required for setting and maintaining the necessary lines and grades shall be the Contractor's responsibility. The Contractor shall build the ADA features within the specifications in the Standard Plans and contract documents.

ADA Feature Contract Compliance

The Contractor shall be responsible for completing measurements to verify all ADA features comply with the Contract in the presence of the Engineer.

ADA Feature As-Built Measurements

The Contractor shall be responsible for providing the latitude and longitude of each ADA feature as indicated on the ADA Inspection Form(s) (WSDOT Form 224-020).

The completed ADA Inspection Form(s) (WSDOT Form 224-020) shall be submitted as a Type 3 Working Drawing and transmitted to the Engineer within 30 calendar days of completing the ADA feature. After acceptance, the Contracting Agency will submit the final form(s) to the WSDOT ADA Steward.

Payment

Payment will be made for the following bid item that is included in the Proposal:

"ADA Features Surveying", lump sum.

The lump sum Contract price for "ADA Features Surveying" shall be full pay for all the Work as specified.

In the instance where an ADA feature does not meet accessibility requirements, all work to replace non-compliant work and then to measure, record the as-built measurements, and transmit the electronic forms to the Engineer shall be completed at no additional cost to the Contracting Agency.

CITY OF FEDERAL WAY

SP-17

**21ST AVE S & S 320TH STREET
SIGNALIZATION AND PEDESTRIAN
IMPROVEMENTS PROJECT
PROJECT #36225**

CFW SPECIAL PROVISIONS VER. 2023.06

1-05.7 Removal of Defective and Unauthorized Work
(October 1, 2005 APWA GSP)

Supplement this section with the following:

If the Contractor fails to remedy defective or unauthorized work within the time specified in a written notice from the Engineer, or fails to perform any part of the work required by the Contract Documents, the Engineer may correct and remedy such work as may be identified in the written notice, with Contracting Agency forces or by such other means as the Contracting Agency may deem necessary.

If the Contractor fails to comply with a written order to remedy what the Engineer determines to be an emergency situation, the Engineer may have the defective and unauthorized work corrected immediately, have the rejected work removed and replaced, or have work the Contractor refuses to perform completed by using Contracting Agency or other forces. An emergency situation is any situation when, in the opinion of the Engineer, a delay in its remedy could be potentially unsafe, or might cause serious risk of loss or damage to the public.

Direct or indirect costs incurred by the Contracting Agency attributable to correcting and remedying defective or unauthorized work, or work the Contractor failed or refused to perform, shall be paid by the Contractor. Payment will be deducted by the Engineer from monies due, or to become due, the Contractor. Such direct and indirect costs shall include in particular, but without limitation, compensation for additional professional services required, and costs for repair and replacement of work of others destroyed or damaged by correction, removal, or replacement of the Contractor's unauthorized work.

No adjustment in Contract time or compensation will be allowed because of the delay in the performance of the work attributable to the exercise of the Contracting Agency's rights provided by this section.

The rights exercised under the provisions of this section shall not diminish the Contracting Agency's right to pursue any other avenue for additional remedy or damages with respect to the Contractor's failure to perform the work as required.

1-05.11 Final Inspection
(October 1, 2005 APWA GSP)

Delete this section and replace it with the following:

1-05.11 Final Inspections and Operational Testing

1-05.11(1) Substantial Completion Date

When the Contractor considers the work to be substantially complete, the Contractor shall so notify the Engineer and request the Engineer establish the Substantial Completion Date. The Contractor's request shall list the specific items of work that remain to be completed in order to reach physical completion. The Engineer will schedule an inspection of the work with the Contractor to determine the status of completion. The Engineer may also establish the Substantial Completion Date unilaterally.

CITY OF FEDERAL WAY

SP-18

**21ST AVE S & S 320TH STREET
SIGNALIZATION AND PEDESTRIAN
IMPROVEMENTS PROJECT
PROJECT #36225**

CFW SPECIAL PROVISIONS VER. 2023.06

If, after this inspection, the Engineer concurs with the Contractor that the work is substantially complete and ready for its intended use, the Engineer, by written notice to the Contractor, will set the Substantial Completion Date. If, after this inspection the Engineer does not consider the work substantially complete and ready for its intended use, the Engineer will, by written notice, so notify the Contractor giving the reasons therefore.

Upon receipt of written notice concurring in or denying substantial completion, whichever is applicable, the Contractor shall pursue vigorously, diligently and without unauthorized interruption, the work necessary to reach Substantial and Physical Completion. The Contractor shall provide the Engineer with a revised schedule indicating when the Contractor expects to reach substantial and physical completion of the work.

The above process shall be repeated until the Engineer establishes the Substantial Completion Date and the Contractor considers the work physically complete and ready for final inspection.

1-05.11(2) Final Inspection and Physical Completion Date

When the Contractor considers the work physically complete and ready for final inspection, the Contractor by written notice, shall request the Engineer to schedule a final inspection. The Engineer will set a date for final inspection. The Engineer and the Contractor will then make a final inspection and the Engineer will notify the Contractor in writing of all particulars in which the final inspection reveals the work incomplete or unacceptable. The Contractor shall immediately take such corrective measures as are necessary to remedy the listed deficiencies. Corrective work shall be pursued vigorously, diligently, and without interruption until physical completion of the listed deficiencies. This process will continue until the Engineer is satisfied the listed deficiencies have been corrected.

If action to correct the listed deficiencies is not initiated within 7 days after receipt of the written notice listing the deficiencies, the Engineer may, upon written notice to the Contractor, take whatever steps are necessary to correct those deficiencies pursuant to Section 1-05.7.

The Contractor will not be allowed an extension of Contract time because of a delay in the performance of the work attributable to the exercise of the Engineer's right hereunder.

Upon correction of all deficiencies, the Engineer will notify the Contractor and the Contracting Agency, in writing, of the date upon which the work was considered physically complete. That date shall constitute the Physical Completion Date of the Contract, but shall not imply acceptance of the work or that all the obligations of the Contractor under the Contract have been fulfilled.

1-05.11(3) Operational Testing

It is the intent of the Contracting Agency to have at the Physical Completion Date a complete and operable system. Therefore when the work involves the installation of machinery or other mechanical equipment; street lighting, electrical distribution or signal systems; irrigation systems; buildings; or other similar work it may be desirable for the Engineer to have the Contractor operate and test the work for a period of time after final

CITY OF FEDERAL WAY

**21ST AVE S & S 320TH STREET
SIGNALIZATION AND PEDESTRIAN
IMPROVEMENTS PROJECT
PROJECT #36225**

SP-19

CFW SPECIAL PROVISIONS VER. 2023.06

inspection but prior to the physical completion date. Whenever items of work are listed in the Contract Provisions for operational testing they shall be fully tested under operating conditions for the time period specified to ensure their acceptability prior to the Physical Completion Date. During and following the test period, the Contractor shall correct any items of workmanship, materials, or equipment which prove faulty, or that are not in first class operating condition. Equipment, electrical controls, meters, or other devices and equipment to be tested during this period shall be tested under the observation of the Engineer, so that the Engineer may determine their suitability for the purpose for which they were installed. The Physical Completion Date cannot be established until testing and corrections have been completed to the satisfaction of the Engineer.

The costs for power, gas, labor, material, supplies, and everything else needed to successfully complete operational testing, shall be included in the unit Contract prices related to the system being tested, unless specifically set forth otherwise in the Proposal.

Operational and test periods, when required by the Engineer, shall not affect a manufacturer's guaranties or warranties furnished under the terms of the Contract.

1-05.12 Final Acceptance
(April 12, 2019 CFW GSP)

Delete the third and fourth sentences in the first paragraph and replace it with the following:
Final acceptance date of the work shall be the date the Federal Way City Council accepts the project as complete.

Add the following new section.

1-05.12(1) One-Year Guarantee Period

(March 8, 2013 APWA GSP)

The Contractor shall return to the project and repair or replace all defects in workmanship and material discovered within one year after Final Acceptance of the Work. The Contractor shall start work to remedy any such defects within 7 calendar days of receiving Contracting Agency's written notice of a defect, and shall complete such work within the time stated in the Contracting Agency's notice. In case of an emergency, where damage may result from delay or where loss of services may result, such corrections may be made by the Contracting Agency's own forces or another contractor, In which case the cost of corrections shall be paid by the Contractor. In the event the Contractor does not accomplish corrections within the time specified, the work will be otherwise accomplished and the cost of same shall be paid by the Contractor.

When corrections of defects are made, the Contractor shall then be responsible for correcting all defects in workmanship and materials in the corrected work for one year after acceptance of the corrections by Contracting Agency.

This guarantee is supplemental to and does not limit or affect the requirements that the Contractor's work comply with the requirements of the Contract or any other legal rights or remedies of the Contracting Agency.

1-05.13 Superintendents, Labor and Equipment of Contractor

CITY OF FEDERAL WAY

SP-20

21ST AVE S & S 320TH STREET
SIGNALIZATION AND PEDESTRIAN
IMPROVEMENTS PROJECT
PROJECT #36225

(August 14, 2013 APWA GSP)

Delete the sixth and seventh paragraphs of this section.

1-05.14 Cooperation with Other Contractors

(March 13, 1995 WSDOT GSP, OPTION 1)

Section 1-05.14 is supplemented with the following:

Other Contracts or Other Work

It is anticipated that the following work adjacent to or within the limits of this project will be performed by others during the course of this project and will require coordination of the work:

Construction of the Sound Transit Federal Way Link Extension. This project borders the construction of the Federal Way station, including construction of improvements within the public ROW at the northeast corner of the intersection which will be previously improved by Sound Transit. Contact information for this project is as follows:

Sound Transit
Michael Hall
Deputy Construction Manager, FWLE
C: 313-687-7929
Michael.Hall@soundtransit.org

1-05.15 Method of Serving Notices

(December 30, 2022 APWA GSP)

Revise the second paragraph to read:

All correspondence from the Contractor shall be directed to the Project Engineer. All correspondence from the Contractor constituting any notification, notice of protest, notice of dispute, or other correspondence constituting notification required to be furnished under the Contract, must be in paper format, hand delivered or sent via mail delivery service to the Project Engineer's office. Electronic copies such as e-mails or electronically delivered copies of correspondence will not constitute such notice and will not comply with the requirements of the Contract.

Add the following new section:

1-05.16 Water and Power

(October 1, 2005 APWA GSP)

The Contractor shall make necessary arrangements, and shall bear the costs for power and water necessary for the performance of the work, unless the Contract includes power and water as a pay item.

1-05.17 As-Built Survey and Record Drawings

(March 22, 2023 CFW GSP)

Section 1-05.17 is a new section:

As-Built Survey

After construction has been completed the Contractor shall perform an as-built survey and provide the information (including point files) in a format compatible with AutoCAD 2019 or later version file to the Engineer.

CITY OF FEDERAL WAY

SP-21

21ST AVE S & S 320TH STREET
SIGNALIZATION AND PEDESTRIAN
IMPROVEMENTS PROJECT
PROJECT #36225

CFW SPECIAL PROVISIONS VER. 2023.06

*** PLAN CENTER COPY *** Official bid documents, plan holder's list, and addenda (if applicable) are available on BXWA.com

The applicable tolerance limits for the as-built survey include, but are not limited to the following:

	Vertical	Horizontal
As-built sanitary & storm invert and grate elevations	± 0.01 foot	± 0.01 foot
As-built monumentation	± 0.001 foot	± 0.001 foot
As-built waterlines, inverts, valves, hydrants	± 0.10 foot	± 0.10 foot
As-built ponds/swales/water features	± 0.10 foot	± 0.10 foot
As-built buildings (fin. Floor elev.)	± 0.01 foot	± 0.10 foot
As-built gas lines, power, TV, Tel, Com	± 0.10 foot	± 0.10 foot
As-built signs, signals, etc.	N/A	± 0.10 foot

This as-built survey shall consist of the following:

- Survey of rim elevation, sump elevations, and invert elevations of all storm drainage structures installed, modified or left in place within the limits of this contract. Storm pipe diameter and material; drainage structure type, size, lid type (solid cover or grate, standard or heavy duty), and lid shape; model No. of CB water quality treatment inserts installed, flowline of open channel conveyance systems at 50-foot max. intervals, and retaining wall footing drains, including cleanouts.
- Survey of all monuments shown on the plans or discovered within the project limits. City of Federal Way Monument Record forms shall be completed by a Professional Land Surveyor and submitted to the Project Engineer for each monument.
- Finished grade shots on all utility appurtenances within the limits of this contract, including, but not limited to vaults, handholes, valves, fire hydrants, water meters, junction boxes, signal poles, etc. Appurtenances with round covers should have one survey shot in the center of the manhole or valve cover, or at the center of the fire hydrant. Utility handholes and boxes shall have two shots on opposite corners of the cover.
- Final curb elevations, with a minimum of 8 shots at each curb return. Also, final shots along all curb and gutter, block curb, integral curb and extruded curb installed in this contract (at flowline of the curbs).
- Final elevations at the front and back of walk throughout the project limits.
- Final wall elevations at the face and top of all walls installed in this contract.
- Shots of all signs, trees, illumination and signal equipment installed as part of this contract.
- Shots to delineate all channelization installed in this contract.

CITY OF FEDERAL WAY

**21ST AVE S & S 320TH STREET
SIGNALIZATION AND PEDESTRIAN
IMPROVEMENTS PROJECT
PROJECT #36225**

SP-22

CFW SPECIAL PROVISIONS VER. 2023.06

Record Drawings

Throughout construction, the Contractor shall be responsible for tracking all relevant field changes to the approved construction drawings. These changes shall be clearly identified in red ink in a comprehensive manner on one set of full size Plans. These Record Drawing shall be kept separate from other Plan sheets, and shall be clearly marked as Record Drawings. The Record Drawings shall be kept on site, and shall be available for review by the Contracting Agency at all times. The Contractor shall bring the Record Drawings to each progress meeting for review.

Upon completion of construction, the Contractor shall submit to the City a clean set of marked-up drawings in electronic PDF format that are signed and certified by the Contractor or their surveyor. The Certification on each page of the record drawings shall state that said drawings are an accurate depiction of built conditions. City acceptance of the Record Drawings is one of the requirements for achieving Physical Completion.

The certified Record Drawings shall, at a minimum, consist of the following:

- Existing or abandoned utilities that were encountered during construction that were not shown on the approved construction drawings.
- Accurate locations of storm drainage (including invert elevations), sanitary sewer, water mains and other water appurtenances, structures, conduits, light standards, vaults, width of roadways, sidewalks, landscaping areas, channelization and pavement markings, etc. Record drawings shall reflect actual dimensions, arrangement, and materials used when different than shown in the Plans. As-built survey information shall be used to confirm information shown on record drawings.
- Changes made by Change Order or Field Directive
- Changes made by the Contractor as approved by the Engineer.
- Pothole information gathered by the Contractor.

Payment

"As-Built Survey and Record Drawings", lump sum.

The lump sum contract price for "As-Built Survey and Record Drawings " shall be full pay for all labor, equipment, materials, and supervision utilized to perform the work specified, including any surveying, checking, correction of errors, preparation of record drawings, and coordination efforts. Payment will be made after AutoCad files and record drawings are submitted to and approved by the City. No partial payments will be made.

1-05.18 Contractor's Daily Diary ***(March 22, 2023 CFW GSP)***

Section 1-05.18 is a new section:

The Contractor and subcontractors, as additional consideration for payment for this contract work, hereby agree to maintain and provide to the Owner and the Engineer a Daily Diary Record of this Work. The diary must be kept and maintained by the Contractor's designated project superintendent. Entries must be made on a daily basis and must accurately represent all of the project activities on each day.

CITY OF FEDERAL WAY

SP-23

**21ST AVE S & S 320TH STREET
SIGNALIZATION AND PEDESTRIAN
IMPROVEMENTS PROJECT
PROJECT #36225**

CFW SPECIAL PROVISIONS VER. 2023.06

At a minimum, the diary shall show on a daily basis:

- The day and date.
- The weather conditions, including changes throughout the day.
- A complete description of work accomplished during the day with adequate references to the Plans and Specifications so that the reader can easily and accurately identify said work in the Plans.
- An entry for each and every changed condition, dispute or potential dispute, incident, accident, or occurrence of any nature whatsoever which might affect the Contract, Owner, or any third party in any manner.
- Listing of any materials received and stored on or off-site by the Contractor for future installation, to include the manner of storage and protection of the same.
- Listing of materials installed during each day.
- List of all subcontractors working on-site during each day.
- Listing of the number of Contractor's employees working during each day by category of employment.
- Listing of Contractor's equipment working on the site during each day. Idle equipment on the site shall be listed and designated as idle.
- Notations to explain inspections, testing, stake-out, and all other services furnished to the Contractor by the Owner or other during each day.
- Entries to verify the daily (including non-work days) inspection and maintenance of traffic control devices and condition of the traveled roadway surfaces. The Contractor shall not allow any conditions to develop that would be hazardous to the public.
- Any other information that serves to give an accurate and complete record of the nature, quantity, and quality of the Contractor's progress on each day.
- Summary of total number of working days to date, and total number of delay days to date.

The Contractor's designated project superintendent must sign the diary at the end of each working day. The Contractor must provide a copy of the diary to the Owner and the Engineer each morning for the preceding workday. All copies must be legible.

It is expressly agreed between the contractor and the owner that the daily diary maintained by the Contractor shall be the "Contractor's Book of Original Entry" for the documentation of any potential claims or disputes that might arise during this contract. Failure of the Contractor to maintain this diary in the manner described above will constitute a waiver of any such claims or disputes by the Contractor. The daily diary maintained by the Contractor does not constitute the official record of the project. The official record of the project is prepared and maintained exclusively by the engineer.

1-05.19 Defects Arising in One Year and Remedies
(February 15, 2019 CFW GSP)

Section 1-05.19 is a new section:

The Contractor shall, at its own sole cost and expense, be responsible for correcting all defects in workmanship and material discovered within one year after acceptance of this work by the City of Federal Way. When corrections of defects are made, the Contractor shall be responsible for correcting all defects in workmanship and/or materials in the

CITY OF FEDERAL WAY

SP-24

**21ST AVE S & S 320TH STREET
SIGNALIZATION AND PEDESTRIAN
IMPROVEMENTS PROJECT
PROJECT #36225**

CFW SPECIAL PROVISIONS VER. 2023.06

corrected work for one year after acceptance of the corrections by the Owner. Conducting of tests and inspections, review of specifications or plans, payment for goods or services, or acceptance by the City does not constitute waiver, modification, or exclusion of any express or implied warranty or any right under law. This warranty shall survive termination of this Contract.

The Contractor shall start work to remedy such defects within seven (7) calendar days of mailing notice of discovery thereof by the Owner and shall complete such work within a reasonable time. In emergencies, where damage may result from delay or where loss of services may result, such corrections may be made by the Owner, in which case the cost shall be borne by the Contractor. In the event the Contractor does not accomplish corrections at the time specified, the work will be otherwise accomplished and the cost of same shall be paid by the Contractor. These actions will be pursuant to the provisions of Section 1-05.8 of the Standard Specifications.

The Contractor shall be liable for any costs, losses, expenses, or damages, including consequential damages suffered by the Owner resulting from defects in the Contractor's work including, but not limited to, cost of materials and labor extended by Owner in making emergency repairs and cost of engineering, inspection and supervision by the Owner or the Engineer. The Contractor shall hold the Owner harmless from any and all claims which may be made against the Owner as a result of any defective work, and the Contractor shall defend any such claims at his own expense.

The Contractor agrees the above one-year limitation shall not exclude or diminish the Owner's rights under any law to obtain damages and recover costs resulting from defective and unauthorized work discovered after one year but prior to the expiration of the legal time period set forth in RCW 9.16.040 limiting actions upon a contract in writing or liability, expressed or implied, arising out of a written agreement. This warranty may also extend beyond the one year time period pursuant to any other warranties specified in the Special Provisions, Contract Plans, other parts of the Contract Documents, or incorporated by this reference.

1-06 CONTROL OF MATERIAL

1-06.6 Recycled Materials ***(January 4, 2016 APWA GSP)***

Delete this section, including its subsections, and replace it with the following:

The Contractor shall make their best effort to utilize recycled materials in the construction of the project. Approval of such material use shall be as detailed elsewhere in the Standard Specifications.

Prior to Physical Completion the Contractor shall report the quantity of recycled materials that were utilized in the construction of the project for each of the items listed in Section 9-03.21. The report shall include hot mix asphalt, recycled concrete aggregate, recycled glass, steel furnace slag and other recycled materials (e.g. utilization of on-site material and aggregates from concrete returned to the supplier). The Contractor's report shall be provided on DOT form 350-075 Recycled Materials Reporting.

CITY OF FEDERAL WAY

SP-25

**21ST AVE S & S 320TH STREET
SIGNALIZATION AND PEDESTRIAN
IMPROVEMENTS PROJECT
PROJECT #36225**

CFW SPECIAL PROVISIONS VER. 2023.06

1-07 LEGAL RELATIONS AND RESPONSIBILITIES TO THE PUBLIC

1-07.1 Laws to be Observed ***(October 1, 2005 APWA GSP)***

Supplement this section with the following:

In cases of conflict between different safety regulations, the more stringent regulation shall apply.

The Washington State Department of Labor and Industries shall be the sole and paramount administrative agency responsible for the administration of the provisions of the Washington Industrial Safety and Health Act of 1973 (WISHA).

The Contractor shall maintain at the project site office, or other well-known place at the project site, all articles necessary for providing first aid to the injured. The Contractor shall establish, publish, and make known to all employees, procedures for ensuring immediate removal to a hospital, or doctor's care, persons, including employees, who may have been injured on the project site. Employees should not be permitted to work on the project site before the Contractor has established and made known procedures for removal of injured persons to a hospital or a doctor's care.

The Contractor shall have sole responsibility for the safety, efficiency, and adequacy of the Contractor's Plant, appliances, and methods, and for any damage or injury resulting from their failure, or improper maintenance, use, or operation. The Contractor shall be solely and completely responsible for the conditions of the project site, including safety for all persons and property in the performance of the work. This requirement shall apply continuously, and not be limited to normal working hours. The required or implied duty of the Engineer to conduct construction review of the Contractor's performance does not, and shall not, be intended to include review and adequacy of the Contractor's safety measures in, on, or near the project site.

Section 1-07.1 is supplemented with the following:

(April 12, 2019 CFW GSP)

Confined Space

Confined spaces are known to exist at the following locations:

Existing storm drainage, sanitary sewer, and other utility systems, vaults, and structures, along with all new similar new construction items that meet the requirements of WAC 296-809-100.

The Contractor shall be fully responsible for the safety and health of all on-site workers and compliant with Washington Administrative Code (WAC 296-809).

The Contractor shall prepare and implement a confined space program for each of the confined spaces identified above. The Contractors Confined Space program shall be sent to the contracting agency at least 5 days prior to the Contractor beginning work in or adjacent to the confined space. No work shall be performed in or adjacent to the confined space until the plan is submitted to the Engineer as required. The Contractor shall communicate with the Engineer to ensure a coordinated effort for providing and maintaining a safe worksite for both the Contracting Agency's and Contractor's workers when working in or near a confined space.

CITY OF FEDERAL WAY

SP-26

**21ST AVE S & S 320TH STREET
SIGNALIZATION AND PEDESTRIAN
IMPROVEMENTS PROJECT
PROJECT #36225**

CFW SPECIAL PROVISIONS VER. 2023.06

All costs to prepare and implement the confined space program shall be included in the bid prices for the various items associated with the confined space work.

1-07.2 State Taxes

Delete this section, including its sub-sections, in its entirety and replace it with the following:

1-07.2 State Sales Tax ***(June 27, 2011 APWA GSP)***

The Washington State Department of Revenue has issued special rules on the State sales tax. Sections 1-07.2(1) through 1-07.2(3) are meant to clarify those rules. The Contractor should contact the Washington State Department of Revenue for answers to questions in this area. The Contracting Agency will not adjust its payment if the Contractor bases a Bid on a misunderstood tax liability.

The Contractor shall include all Contractor-paid taxes in the unit Bid prices or other Contract amounts. In some cases, however, state retail sales tax will not be included. Section 1-07.2(2) describes this exception.

The Contracting Agency will pay the retained percentage (or release the Contract Bond if a FHWA-funded Project) only if the Contractor has obtained from the Washington State Department of Revenue a certificate showing that all Contract-related taxes have been paid (RCW 60.28.051). The Contracting Agency may deduct from its payments to the Contractor any amount the Contractor may owe the Washington State Department of Revenue, whether the amount owed relates to this Contract or not. Any amount so deducted will be paid into the proper State fund.

1-07.2(1) State Sales Tax — Rule 171

WAC 458-20-171, and its related rules, apply to building, repairing, or improving streets, roads, etc., which are owned by a municipal corporation, or political subdivision of the state, or by the United States, and which are used primarily for foot or vehicular traffic. This includes storm or combined sewer systems within and included as a part of the street or road drainage system and power lines when such are part of the roadway lighting system. For work performed in such cases, the Contractor shall include Washington State Retail Sales Taxes in the various unit Bid item prices, or other Contract amounts, including those that the Contractor pays on the purchase of the materials, equipment, or supplies used or consumed in doing the work.

1-07.2(2) State Sales Tax — Rule 170

WAC 458-20-170, and its related rules, apply to the constructing and repairing of new or existing buildings, or other structures, upon real property. This includes, but is not limited to, the construction of streets, roads, highways, etc., owned by the state of Washington; water mains and their appurtenances; sanitary sewers and sewage disposal systems unless such sewers and disposal systems are within, and a part of, a street or road drainage system; telephone, telegraph, electrical power distribution lines, or other conduits or lines in or above streets or roads, unless such power lines become a part of a street or road lighting system; and installing or attaching of any article of tangible personal property in or to real

CITY OF FEDERAL WAY

**21ST AVE S & S 320TH STREET
SIGNALIZATION AND PEDESTRIAN
IMPROVEMENTS PROJECT
PROJECT #36225**

SP-27

CFW SPECIAL PROVISIONS VER. 2023.06

property, whether or not such personal property becomes a part of the realty by virtue of installation.

For work performed in such cases, the Contractor shall collect from the Contracting Agency, retail sales tax on the full Contract price. The Contracting Agency will automatically add this sales tax to each payment to the Contractor. For this reason, the Contractor shall not include the retail sales tax in the unit Bid item prices, or in any other Contract amount subject to Rule 170, with the following exception.

Exception: The Contracting Agency will not add in sales tax for a payment the Contractor or a subcontractor makes on the purchase or rental of tools, machinery, equipment, or consumable supplies not integrated into the project. Such sales taxes shall be included in the unit Bid item prices or in any other Contract amount.

1-07.2(3) Services

The Contractor shall not collect retail sales tax from the Contracting Agency on any Contract wholly for professional or other services (as defined in Washington State Department of Revenue Rules 138 and 244).

1-07.6 Permits and Licenses

(April 12, 2018 CFW GSP)

Section 1-07.6 is supplemented with the following:

Survey Monuments

In accordance with RCW 58.24.040(8), no cadastral or geodetic survey monument may be disturbed without a valid permit to remove or destroy a survey monument, issued by the Washington State Department of Natural Resources. Permit applications can be obtained on the DNR Public Land Survey Office website. The permit application must be stamped by a registered Washington State Land Surveyor. The Contractor shall obtain the permit to Remove or Destroy a Survey Monument as necessary. All costs to obtain and comply with the permit shall be considered incidental to other bid items and no additional payment will be made.

(December 16, 2022 CFW GSP)

Section 1-07.6 is supplemented with the following:

Oversized Loads

The Contractor must obtain a permit from the City of Federal Way (Development Services Division) for any Oversize / Overweight Loads. Loads are classified as oversized / overweight if they exceed the following criteria:

Size

- 8'6" wide, 14' tall, 53' length (tractor/trailer)
- 40' single unit
- 75' overall with a truck and trailer
- 3' of front overhang and 15' of rear overhang

Weight

- Heavy loads require a permit for overweight if they exceed the vehicle weight table published by WSDOT. The gross vehicle weight for a vehicle or a vehicle combination is determined by an overlapping set of three criteria: tire size, axle weight, and the weight table.

CITY OF FEDERAL WAY

**21ST AVE S & S 320TH STREET
SIGNALIZATION AND PEDESTRIAN
IMPROVEMENTS PROJECT
PROJECT #36225**

SP-28

CFW SPECIAL PROVISIONS VER. 2023.06

1-07.7 Load Limits

(March 13, 1995 WSDOT GSP, OPTION 6)

Section 1-07.7 is supplemented with the following:

If the sources of materials provided by the Contractor necessitate hauling over roads other than State Highways, the Contractor shall, at the Contractor's expense, make all arrangements for the use of the haul routes.

1-07.9(5)A Required Documents

(December 30, 2022 APWA GSP)

This section is revised to read as follows:

All Statements of Intent to Pay Prevailing Wages, Affidavits of Wages Paid and Certified Payrolls, including a signed Statement of Compliance for Federal-aid projects, shall be submitted to the Engineer and to the State using the State L&I online Prevailing Wage Intent & Affidavit (PWIA) system.

1-07.16 Protection and Restoration of Property

1-07.16(2) Vegetation Protection and Restoration

(August 2, 2010 WSDOT GSP)

Section 1-07.16(2) is supplemented with the following:

Vegetation and soil protection zones for trees shall extend out from the trunk to a distance of 1 foot radius for each inch of trunk diameter at breast height.

Vegetation and soil protection zones for shrubs shall extend out from the stems at ground level to twice the radius of the shrub.

Vegetation and soil protection zones for herbaceous vegetation shall extend to encompass the diameter of the plant as measured from the outer edge of the plant.

1-07.17 Utilities and Similar Facilities

(April 2, 2007 WSDOT GSP, OPTION 1)

Section 1-07.17 is supplemented with the following:

Locations and dimensions shown in the Plans for existing facilities are in accordance with available information obtained without uncovering, measuring, or other verification.

The following addresses and telephone numbers of utility companies known or suspected of having facilities within the project limits are supplied for the Contractor's convenience.

UTILITY CONTACTS

Puget Sound Energy (Power)

Attn: Jason Airey
3130 S 38th St
Tacoma, WA 98409
Telephone: (206) 348-9637

Lumen

Attn: Lara Lant
1208 NE 64th St
Seattle, WA 98115
Lara.Lant@Lumen.com
Telephone: (206) 765-9885

CITY OF FEDERAL WAY

**21ST AVE S & S 320TH STREET
SIGNALIZATION AND PEDESTRIAN
IMPROVEMENTS PROJECT
PROJECT #36225**

SP-29

Puget Sound Energy (Gas)

Attn: Katie Dierick
Katie.Dierick@pse.com
Cell: (253) 268-6331

Lakehaven Water & Sewer District

Attn: Naveen Chandra, P.E.
31623 1st Avenue S
Federal Way, WA 98063-4249
NChandra@lakehaven.org
Telephone: (253) 946-5440
Cell: (206) 966-8185

Zayo

Attn: Jason Tesdal
4905 Pacific Hwy E, Suite 4
Fife, WA 98424
Jason.Tesdal@zayo.com
Telephone: (253) 221-7585

King Co. Traffic (Signals & Lighting)

Attn: Mark Parrett
155 Monroe Ave NE
Renton, WA 98056
Telephone: (206) 296-8153

Comcast

Attn: Kyle Kinney
410 Valley Ave NW
Puyallup, WA 98371
Kyle_Kinney@comcast.com
Telephone: (253) 293-3838

AT&T

Attn: Steve Duppenhaler
11241 Willows Rd NE, #130
Redmond, WA 98052
Telephone: (425)286-3822

City of FW IT Dept (City Fiber)

Attn: Thomas Fichtner
33325 8th Ave S
Federal Way, WA 98003
Telephone: (253) 835-2547

ADDITIONAL CONTACTS

King County Metro Transit

81270 6th Ave S, Bldg 2
Seattle, WA 98134
Telephone: (206) 684-2785

South King Fire & Rescue

31617 1st Ave S
Federal Way, WA 98003
Telephone: (253) 946-7253

City of Federal Way Police

33325 8th Ave S
Federal Way, WA 98003
Telephone: (253) 835-6701
(for officer traffic control scheduling)
Telephone: (253) 835-6767
(for traffic / road closure issues)

Federal Way School District

Attn: Transportation Department
1211 S. 332nd St
Federal Way, WA 98003
Telephone: (253) 945-5960

1-07.18 Public Liability and Property Damage Insurance

Delete this section in its entirety, and replace it with the following:

1-07.18 Insurance

(December 30, 2022 APWA GSP)

CITY OF FEDERAL WAY

**21ST AVE S & S 320TH STREET
SIGNALIZATION AND PEDESTRIAN
IMPROVEMENTS PROJECT
PROJECT #36225**

SP-30

1-07.18(1) General Requirements

- A. The Contractor shall procure and maintain the insurance described in all subsections of section 1-07.18 of these Special Provisions, from insurers with a current A. M. Best rating of not less than A-: VII and licensed to do business in the State of Washington. The Contracting Agency reserves the right to approve or reject the insurance provided, based on the insurer's financial condition.
- B. The Contractor shall keep this insurance in force without interruption from the commencement of the Contractor's Work through the term of the Contract and for thirty (30) days after the Physical Completion date, unless otherwise indicated below.
- C. If any insurance policy is written on a claims-made form, its retroactive date, and that of all subsequent renewals, shall be no later than the effective date of this Contract. The policy shall state that coverage is claims made, and state the retroactive date. Claims-made form coverage shall be maintained by the Contractor for a minimum of 36 months following the Completion Date or earlier termination of this Contract, and the Contractor shall annually provide the Contracting Agency with proof of renewal. If renewal of the claims made form of coverage becomes unavailable, or economically prohibitive, the Contractor shall purchase an extended reporting period ("tail") or execute another form of guarantee acceptable to the Contracting Agency to assure financial responsibility for liability for services performed.
- D. The Contractor's Automobile Liability, Commercial General Liability and Excess or Umbrella Liability insurance policies shall be primary and non-contributory insurance as respects the Contracting Agency's insurance, self-insurance, or self-insured pool coverage. Any insurance, self-insurance, or self-insured pool coverage maintained by the Contracting Agency shall be excess of the Contractor's insurance and shall not contribute with it.
- E. The Contractor shall provide the Contracting Agency and all additional insureds with written notice of any policy cancellation, within two business days of their receipt of such notice.
- F. The Contractor shall not begin work under the Contract until the required insurance has been obtained and approved by the Contracting Agency
- G. Failure on the part of the Contractor to maintain the insurance as required shall constitute a material breach of contract, upon which the Contracting Agency may, after giving five business days' notice to the Contractor to correct the breach, immediately terminate the Contract or, at its discretion, procure or renew such insurance and pay any and all premiums in connection therewith, with any sums so expended to be repaid to the Contracting Agency on demand, or at the sole discretion of the Contracting Agency, offset against funds due the Contractor from the Contracting Agency.
- H. All costs for insurance shall be incidental to and included in the unit or lump sum prices of the Contract and no additional payment will be made.

(March 9, 2023 WSDOT GSP)

Section 1-07.18(1) is supplemented with the following:

CITY OF FEDERAL WAY

SP-31

**21ST AVE S & S 320TH STREET
SIGNALIZATION AND PEDESTRIAN
IMPROVEMENTS PROJECT
PROJECT #36225**

CFW SPECIAL PROVISIONS VER. 2023.06

Under no circumstances shall a wrap up policy be obtained, for either initiating or maintaining coverage, to satisfy insurance requirements for any policy required under this section. A wrap up policy is defined as an insurance agreement or arrangement under which all the parties working on a specified or designated project are insured under one policy for liability arising out of that specified or designated project.

(December 30, 2022 APWA GSP, cont.)

1-07.18(2) Additional Insured

All insurance policies, with the exception of Workers Compensation, and of Professional Liability and Builder's Risk (if required by this Contract) shall name the following listed entities as additional insured(s) using the forms or endorsements required herein:

- The Contracting Agency and its officers, elected officials, employees, agents, and volunteers.
- The Consultant that completed the preparation of the engineering design and project plans, and its officers, employees, agents, and subconsultants.
- Consultants hired by the Contracting Agency for design, construction support, or materials testing.

The above-listed entities shall be additional insured(s) for the full available limits of liability maintained by the Contractor, irrespective of whether such limits maintained by the Contractor are greater than those required by this Contract, and irrespective of whether the Certificate of Insurance provided by the Contractor pursuant to 1-07.18(4) describes limits lower than those maintained by the Contractor.

For Commercial General Liability insurance coverage, the required additional insured endorsements shall be at least as broad as ISO forms CG 20 10 10 01 for ongoing operations and CG 20 37 10 01 for completed operations.

1-07.18(3) Subcontractors

The Contractor shall cause each subcontractor of every tier to provide insurance coverage that complies with all applicable requirements of the Contractor-provided insurance as set forth herein, except the Contractor shall have sole responsibility for determining the limits of coverage required to be obtained by subcontractors.

The Contractor shall ensure that all subcontractors of every tier add all entities listed in 1-07.18(2) as additional insureds, and provide proof of such on the policies as required by that section as detailed in 1-07.18(2) using an endorsement as least as broad as ISO CG 20 10 10 01 for ongoing operations and CG 20 37 10 01 for completed operations.

Upon request by the Contracting Agency, the Contractor shall forward to the Contracting Agency evidence of insurance and copies of the additional insured endorsements of each subcontractor of every tier as required in 1-07.18(4) Verification of Coverage.

1-07.18(4) Verification of Coverage

The Contractor shall deliver to the Contracting Agency a Certificate(s) of Insurance and endorsements for each policy of insurance meeting the requirements set forth herein when the Contractor delivers the signed Contract for the work. Failure of Contracting Agency to demand such verification of coverage with these insurance requirements or failure of

CITY OF FEDERAL WAY

**21ST AVE S & S 320TH STREET
SIGNALIZATION AND PEDESTRIAN
IMPROVEMENTS PROJECT
PROJECT #36225**

SP-32

CFW SPECIAL PROVISIONS VER. 2023.06

Contracting Agency to identify a deficiency from the insurance documentation provided shall not be construed as a waiver of Contractor's obligation to maintain such insurance.

Verification of coverage shall include:

1. An ACORD certificate or a form determined by the Contracting Agency to be equivalent.
2. Copies of all endorsements naming Contracting Agency and all other entities listed in 1-07.18(2) as additional insured(s), showing the policy number. The Contractor may submit a copy of any blanket additional insured clause from its policies instead of a separate endorsement.
3. Any other amendatory endorsements to show the coverage required herein.
4. A notation of coverage enhancements on the Certificate of Insurance shall not satisfy these requirements – actual endorsements must be submitted.

Upon request by the Contracting Agency, the Contractor shall forward to the Contracting Agency a full and certified copy of the insurance policy(s). If Builders Risk insurance is required on this Project, a full and certified copy of that policy is required when the Contractor delivers the signed Contract for the work.

1-07.18(5) Coverages and Limits

The insurance shall provide the minimum coverages and limits set forth below. Contractor's maintenance of insurance, its scope of coverage, and limits as required herein shall not be construed to limit the liability of the Contractor to the coverage provided by such insurance, or otherwise limit the Contracting Agency's recourse to any remedy available at law or in equity.

All deductibles and self-insured retentions must be disclosed and are subject to approval by the Contracting Agency. The cost of any claim payments falling within the deductible or self-insured retention shall be the responsibility of the Contractor. In the event an additional insured incurs a liability subject to any policy's deductibles or self-insured retention, said deductibles or self-insured retention shall be the responsibility of the Contractor.

1-07.18(5)A Commercial General Liability

Commercial General Liability insurance shall be written on coverage forms at least as broad as ISO occurrence form CG 00 01, including but not limited to liability arising from premises, operations, stop gap liability, independent contractors, products-completed operations, personal and advertising injury, and liability assumed under an insured contract. There shall be no exclusion for liability arising from explosion, collapse or underground property damage.

The Commercial General Liability insurance shall be endorsed to provide a per project general aggregate limit, using ISO form CG 25 03 05 09 or an equivalent endorsement.

Contractor shall maintain Commercial General Liability Insurance arising out of the Contractor's completed operations for at least three years following Substantial Completion of the Work.

CITY OF FEDERAL WAY

SP-33

**21ST AVE S & S 320TH STREET
SIGNALIZATION AND PEDESTRIAN
IMPROVEMENTS PROJECT
PROJECT #36225**

CFW SPECIAL PROVISIONS VER. 2023.06

***** PLAN CENTER COPY *** Official bid documents, plan holder's list, and addenda (if applicable) are available on BXWA.com**

Such policy must provide the following minimum limits:

\$1,000,000	Each Occurrence
\$2,000,000	General Aggregate
\$2,000,000	Products & Completed Operations Aggregate
\$1,000,000	Personal & Advertising Injury each offense
\$1,000,000	Stop Gap / Employers' Liability each Accident

(August 27, 2021 CFW GSP)

The Commercial General Liability minimum coverage limit, per each occurrence shown in Section 1-07.18(5)A of the APWA Special Provision included herein is modified as follows:

The minimum limit for Commercial General Liability Insurance, per each occurrence shall be \$2,000,000.

(December 30, 2022 APWA GSP, cont.)

1-07.18(5)B Automobile Liability

Automobile Liability shall cover owned, non-owned, hired, and leased vehicles; and shall be written on a coverage form at least as broad as ISO form CA 00 01. If the work involves the transport of pollutants, the automobile liability policy shall include MCS 90 and CA 99 48 endorsements.

Such policy must provide the following minimum limit:

\$1,000,000	Combined single limit each accident
-------------	-------------------------------------

1-07.18(5)C Workers' Compensation

The Contractor shall comply with Workers' Compensation coverage as required by the Industrial Insurance laws of the State of Washington.

1-07.18(5)D Excess or Umbrella Liability

(January 4, 2016 APWA GSP)

The Contractor shall provide Excess or Umbrella Liability insurance with limits of not less than \$3,000,000 each occurrence and annual aggregate. This excess or umbrella liability coverage shall be excess over and as least as broad in coverage as the Contractor's Commercial General and Auto Liability insurance.

All entities listed under 1-07.18(2) of these Special Provisions shall be named as additional insureds on the Contractor's Excess or Umbrella Liability insurance policy.

This requirement may be satisfied instead through the Contractor's primary Commercial General and Automobile Liability coverages, or any combination thereof that achieves the overall required limits of insurance.

1-07.18(5)J Pollution Liability

(January 4, 2016 APWA GSP)

The Contractor shall provide a Contractors Pollution Liability policy, providing coverage for claims involving bodily injury, property damage (including loss of use of tangible property that has not been physically injured), cleanup costs, remediation, disposal or other handling of pollutants, including costs and expenses incurred in the investigation, defense, or settlement of claims, arising out of any one or more of the following:

CITY OF FEDERAL WAY

**21ST AVE S & S 320TH STREET
SIGNALIZATION AND PEDESTRIAN
IMPROVEMENTS PROJECT
PROJECT #36225**

SP-34

1. Contractor's operations related to this project.
2. Remediation, abatement, repair, maintenance or other work with lead-based paint or materials containing asbestos.
3. Transportation of hazardous materials away from any site related to this project.

All entities listed under 1-07.18(2) of these Special Provisions shall be named by endorsement as additional insureds on the Contractors Pollution Liability insurance policy.

Such Pollution Liability policy shall provide the following minimum limits:
\$2,000,000 each loss and annual aggregate

1-07.23 Public Convenience and Safety

(February 6, 2023 WSDOT GSP, OPTION 5)

Section 1-07.23(1) is supplemented with the following:

Lane, ramp, shoulder, and roadway closures are subject to the following restrictions:

- The Contractor shall, at all times throughout the project, conduct the work in such a manner as will obstruct and inconvenience vehicular and pedestrian traffic as little as possible. The streets, sidewalks and private driveways shall be kept open by the Contractor except for the brief periods when actual work is being done. The Contractor shall conduct his operations so as to have under construction no greater length or amount of work than he can prosecute vigorously and he shall not open up sections of the work and leave them in an unfinished condition.
- The Contractor shall provide flaggers, signs, and other traffic control devices. The Contractor shall erect and maintain all construction signs, warning signs, detour signs, and other traffic control devices necessary to warn and protect the public at all times from injury or damage as a result of the Contractor's operations which may occur on highways, roads, streets, sidewalks, or paths. No work shall be done on or adjacent to any traveled way until all necessary signs and traffic control devices are in place.
- All signs and traffic control devices for the permitted closures shall only be installed during the specified hours. Construction signs, if placed earlier than the specified hours of closure, shall be turned or covered so as not to be visible to motorists
- The Contractor shall keep all pedestrian routes & access points (including, but not limited to, sidewalks, and crosswalks when located within the project limits) open and clear at all times unless permitted otherwise by the Engineer in an approved traffic control plan. An ADA accessible route must be provided through the project site at all times.

CITY OF FEDERAL WAY

**21ST AVE S & S 320TH STREET
SIGNALIZATION AND PEDESTRIAN
IMPROVEMENTS PROJECT
PROJECT #36225**

SP-35

CFW SPECIAL PROVISIONS VER. 2023.06

- Pedestrians must have access to pedestrian push buttons at all times.
- Lane closures shall not impact business access. All businesses shall remain accessible by vehicles and pedestrian during business hours.
- Lane closures shall not restrict vehicular access for buses through the project site. Bus stops shall remain ADA accessible to pedestrians at all times throughout the project.
- The Contractor shall be responsible for notifying all affected property owners and tenants prior to commencing the barricading of streets, alleys, sidewalks and driveways. Notifications should be at least 48 hours in advance of closures, if possible.
- No paving or planing (milling) shall occur in residential areas during refuse, recycle, and yard waste collection days. Collection schedules are available at www.cityoffederalway.com/publicworks/recycling.
- For approved night work, it shall be the Contractor's responsibility to obtain any required noise variance or exemption for such work.
- For approved night work, the Contractor shall, at no additional cost to the City, make all arrangements for operations during hours of darkness. Flagger stations shall be illuminated using a minimum 150-watt floodlight. Lighting used for nighttime work shall, whenever possible, be directed away from or shielded from residences and oncoming traffic. Signs and barricades shall be supplemented by Type C steady burn lights to delineate edge of roadway during the hours of darkness.
- The Contractor may, if shown on a traffic control plan approved by the Engineer, momentarily interrupt continuous two-way traffic to allow one-way traffic (alternating directions / flagger controlled). Such interruptions shall utilize qualified flaggers placed in strategic locations to insure the public safety and minimize driver confusion.
- For projects with bid schedules located in multiple locations throughout the City, the Contractor shall not have personnel or subcontractors working on-site at more than two schedules at any given time.
- Lane closures on S. 320th St. may only occur between the hours of 7:00AM and 3:30PM, during Daylight Savings Time, 8:00 to 4:30 Standard Time.
- The existing eastbound and westbound left-turn lanes on S 320th Street will be required to be closed once work begins on the island construction, until the signal is operational. No closure of the left-turn lanes on S 320th Street will be allowed until the contractor has shown

CITY OF FEDERAL WAY

**21ST AVE S & S 320TH STREET
SIGNALIZATION AND PEDESTRIAN
IMPROVEMENTS PROJECT
PROJECT #36225**

SP-36

CFW SPECIAL PROVISIONS VER. 2023.06

they have all materials on hand to complete the work within the island and complete the traffic signal.

- Full closures on S. 320th St. may only occur between 10pm and 5am. Mast arm erection and signal turn on shall require full closure of the intersection.

If the Engineer determines the permitted closure hours adversely affect traffic, the Engineer may adjust the hours accordingly. The Engineer will notify the Contractor in writing of any change in the closure hours. Exceptions to these restrictions are listed below and when applicable take precedence over closures listed above. The Engineer may also consider on a case-by-case basis additional exceptions following a written request by the Contractor.

Lane, ramp, shoulder, and roadway closures are not allowed on any of the following:

1. A holiday,
2. A holiday weekend; holidays that occur on Friday, Saturday, Sunday or Monday are considered a holiday weekend. A holiday weekend includes Saturday, Sunday, and the holiday.
3. After 12:00 PM (noon) on the day prior to a holiday or holiday weekend, and
4. Before 7:00 AM on the day after the holiday or holiday weekend.
5. Within the City Center zone from the Friday after Thanksgiving Day (“Black Friday”) until the first City recognized business day of the following year without written approval by the Engineer. The boundaries of the City Center zone are identified in the City of Federal Way Comprehensive Plan. In general, it is the area located within the following boundaries:
 - Northern boundary: S 312th Street
 - Southern boundary: S 324th Street
 - Eastern boundary: Interstate 5
 - Western boundary: 14th Ave S (future extension) / Federal Way 320th Library / 11th Pl S

Traffic Delays

When Automated Flagger Assistance Devices (AFADs) or flaggers are used to control traffic, traffic shall not be stopped for more than two minutes at any time. All traffic congestion shall be allowed to clear before traffic is delayed again.

If the delay becomes greater than two minutes, the Contractor shall immediately begin to take action to cease the operations that are causing the delays. If the two minute delay limit has been exceeded, as determined by the Engineer, the Contractor shall provide to the Engineer, a written proposal to revise his work

CITY OF FEDERAL WAY

**21ST AVE S & S 320TH STREET
SIGNALIZATION AND PEDESTRIAN
IMPROVEMENTS PROJECT
PROJECT #36225**

SP-37

CFW SPECIAL PROVISIONS VER. 2023.06

operations to meet the two minute limit. This proposal shall be accepted by the Engineer prior to resuming any work requiring traffic control.

There shall be no delay to medical, fire, or other emergency vehicles. The Contractor shall alert all flaggers and personnel of this requirement.

General Restrictions

Construction vehicles using a closed traffic lane shall travel only in the normal direction of traffic flow unless expressly allowed in an accepted traffic control plan. Construction vehicles shall be equipped with flashing or rotating amber lights.

No two consecutive on-ramps, off-ramps, or intersections shall be closed at the same time and only one ramp at an interchange shall be closed, unless specifically shown in the Plans.

Roads or ramps that are designated as part of a detour shall not be closed or restricted during the implementation of that detour, unless specifically shown in the Plans.

Controlled Access

No special access or egress shall be allowed by the Contractor other than normal legal movements or as shown in the Plans.

Contractor's vehicles of 10,000 GVW or greater shall not exit or enter a lane open to public traffic except as follows:

Egress and ingress shall only occur during the hours of allowable lane closures, and:

1. For exiting an open lane of traffic, by decelerating in a lane that is closed during the allowable hours for lane closures.
2. For entering an open lane of traffic, by accelerating in a closed lane during the allowable hours for lane closures.

Traffic control vehicles are excluded from the gross vehicle weight requirement. If placing construction signs will restrict traveled lanes, then the work will be permitted during the hours of allowable lane closures.

Advance Notification

The Contractor shall notify the Engineer in writing of any traffic impacts related to lane closure, shoulder closure, sidewalk closure, or any combination for the week by 12:00 p.m. (noon) Wednesday the week prior to the stated impacts.

The Contractor shall notify the Engineer in writing ten working days in advance of any traffic impacts related to full roadway closure, ramp closure, or both.

The Contractor shall notify the Engineer in writing of any changes to the stated traffic impacts a minimum of 48 hours prior to the traffic impacts.

CITY OF FEDERAL WAY

**21ST AVE S & S 320TH STREET
SIGNALIZATION AND PEDESTRIAN
IMPROVEMENTS PROJECT
PROJECT #36225**

SP-38

CFW SPECIAL PROVISIONS VER. 2023.06

1-07.24 Rights of Way
(July 23, 2015 APWA GSP)

Delete this section and replace it with the following:

Street Right of Way lines, limits of easements, and limits of construction permits are indicated in the Plans. The Contractor's construction activities shall be confined within these limits, unless arrangements for use of private property are made.

Generally, the Contracting Agency will have obtained, prior to bid opening, all rights of way and easements, both permanent and temporary, necessary for carrying out the work. Exceptions to this are noted in the Bid Documents or will be brought to the Contractor's attention by a duly issued Addendum.

Whenever any of the work is accomplished on or through property other than public Right of Way, the Contractor shall meet and fulfill all covenants and stipulations of any easement agreement obtained by the Contracting Agency from the owner of the private property. Copies of the easement agreements may be included in the Contract Provisions or made available to the Contractor as soon as practical after they have been obtained by the Engineer.

Whenever easements or rights of entry have not been acquired prior to advertising, these areas are so noted in the Plans. The Contractor shall not proceed with any portion of the work in areas where right of way, easements or rights of entry have not been acquired until the Engineer certifies to the Contractor that the right of way or easement is available or that the right of entry has been received. If the Contractor is delayed due to acts of omission on the part of the Contracting Agency in obtaining easements, rights of entry or right of way, the Contractor will be entitled to an extension of time. The Contractor agrees that such delay shall not be a breach of contract.

Each property owner shall be given 48 hours notice prior to entry by the Contractor. This includes entry onto easements and private property where private improvements must be adjusted.

The Contractor shall be responsible for providing, without expense or liability to the Contracting Agency, any additional land and access thereto that the Contractor may desire for temporary construction facilities, storage of materials, or other Contractor needs. However, before using any private property, whether adjoining the work or not, the Contractor shall file with the Engineer a written permission of the private property owner, and, upon vacating the premises, a written release from the property owner of each property disturbed or otherwise interfered with by reasons of construction pursued under this contract. The statement shall be signed by the private property owner, or proper authority acting for the owner of the private property affected, stating that permission has been granted to use the property and all necessary permits have been obtained or, in the case of a release, that the restoration of the property has been satisfactorily accomplished. The statement shall include the parcel number, address, and date of signature. Written releases must be filed with the Engineer before the Completion Date will be established.

1-07.28 Communication with Businesses and Property Owners

CITY OF FEDERAL WAY

**21ST AVE S & S 320TH STREET
SIGNALIZATION AND PEDESTRIAN
IMPROVEMENTS PROJECT
PROJECT #36225**

SP-39

CFW SPECIAL PROVISIONS VER. 2023.06

(April 12, 2018 CFW GSP)

Section 1-07.28 is added:

The Contractor will be responsible for communicating all work activities with the property owners / tenants that are located adjacent to the project. The Contractor, along with the City's inspector & project engineer, shall have one formal meeting (door-to-door project walk-through) with the property owners/tenants prior to the start of construction. It will be the Contractor's responsibility to initiate and set up the meeting.

Thereafter, the Contractor shall keep the property owners / tenants informed of their general work locations and upcoming activities by distributing a monthly status/schedule memo to the businesses. The memo shall be approved by the City's Project Engineer prior to distribution.

1-07.29 Coordination with Transit Agencies

(December 1, 2021 CFW GSP)

Section 1-07.29 is added:

The Contractor is required to coordinate with impacted transit agencies. King County Metro and/or Pierce Transit personnel will remove and reinstall all existing bus stop signs and supports within the project limits. A copy of all communications between the contractor and transit agencies shall be forwarded to the City of Federal Way.

King County Metro: King County should be notified in writing at construction.coord@kingcounty.gov a minimum of five business days prior to starting any work impacting bus stops, a temporary lane or road closure. Work requiring removing a bus shelter or sign requires notification in writing a minimum of 30 business days.

Pierce Transit: Pierce Transit should be notified at (253)581-8130 to coordinate.

1-08 PROSECUTION AND PROGRESS

Add the following new section:

1-08.0 Preliminary Matters

(May 25, 2006 APWA GSP)

1-08.0(1) Preconstruction Conference

(October 10, 2008 APWA GSP)

Prior to the Contractor beginning the work, a preconstruction conference will be held between the Contractor, the Engineer, and such other interested parties as may be invited. The purpose of the preconstruction conference will be:

1. To review the initial progress schedule;
2. To establish a working understanding among the various parties associated or affected by the work;
3. To establish and review procedures for progress payment, notifications, approvals, submittals, etc.;
4. To establish normal working hours for the work;
5. To review safety standards and traffic control; and

CITY OF FEDERAL WAY

**21ST AVE S & S 320TH STREET
SIGNALIZATION AND PEDESTRIAN
IMPROVEMENTS PROJECT
PROJECT #36225**

SP-40

CFW SPECIAL PROVISIONS VER. 2023.06

6. To discuss such other related items as may be pertinent to the work.

The Contractor shall prepare and submit at the preconstruction meeting the following:

1. A breakdown of all lump sum items;
2. A preliminary schedule of working drawing submittals; and
3. A list of material sources for approval if applicable.

1-08.0(2) Hours of Work
(December 8, 2014 APWA GSP)

Add the following new section:

Except in the case of emergency or unless otherwise approved by the Engineer, the normal working hours for the Contract shall be any consecutive 8-hour period between 7:00 a.m. and 6:00 p.m. Monday through Friday, exclusive of a lunch break. If the Contractor desires different than the normal working hours stated above, the request must be submitted in writing prior to the preconstruction conference, subject to the provisions below. The working hours for the Contract shall be established at or prior to the preconstruction conference.

All working hours and days are also subject to local permit and ordinance conditions (such as noise ordinances).

If the Contractor wishes to deviate from the established working hours, the Contractor shall submit a written request to the Engineer for consideration. This request shall state what hours are being requested, and why. Requests shall be submitted for review no later than noon two working days prior to the day(s) the Contractor is requesting to change the hours.

If the Contracting Agency approves such a deviation, such approval may be subject to certain other conditions, which will be detailed in writing. For example:

1. On non-Federal aid projects, requiring the Contractor to reimburse the Contracting Agency for the costs in excess of straight-time costs for Contracting Agency representatives who worked during such times. (The Engineer may require designated representatives to be present during the work. Representatives who may be deemed necessary by the Engineer include, but are not limited to: survey crews; personnel from the Contracting Agency's material testing lab; inspectors; and other Contracting Agency employees or third party consultants when, in the opinion of the Engineer, such work necessitates their presence.)
2. Considering the work performed on Saturdays, Sundays, and holidays as working days with regard to the contract time.
3. Considering multiple work shifts as multiple working days with respect to contract time even though the multiple shifts occur in a single 24-hour period.

CITY OF FEDERAL WAY

SP-41

**21ST AVE S & S 320TH STREET
SIGNALIZATION AND PEDESTRIAN
IMPROVEMENTS PROJECT
PROJECT #36225**

CFW SPECIAL PROVISIONS VER. 2023.06

4. If a 4-10 work schedule is requested and approved the non-working day for the week will be charged as a working day.
5. If Davis Bacon wage rates apply to this Contract, all requirements must be met and recorded properly on certified payroll.

(December 1, 2021 CFW GSP)

Add the following new section:

The Contractor may request extended work hours on days when paving operations are occurring. Work hours may be modified to 7:00 a.m. to 5:30 p.m. on paving days if the Engineer determines that the benefits of extended working hours will minimize the overall impacts to traffic. Extended work hours for paving will require PCMS boards to be placed a minimum of 2 business days prior to the paving day. Payment for PCMS boards shall be considered incidental to the Contractor's operations, unless there is a specific bid item for PCMS boards.

1-08.1 Subcontracting

1-08.1(7)A Payment Certification

(December 30, 2022 APWA GSP)

Delete this section.

1-08.3 Progress Schedule

1-08.3(1) General Requirements

(October 3, 2022 WSDOT GSP, OPTION 2)

Section 1-08.3(1) is supplemented with the following:

In addition to information required in Items 1 through 6, the Progress Schedule shall include the following milestones and/or activities:

7. Materials requiring long procurement or fabrication periods, such as signal or light poles, structural elements, or mechanical items.

1-08.3(2)A Type A Progress Schedule

(December 30, 2022 APWA GSP)

Revise this section to read:

The Contractor shall submit 2 copies of a Type A Progress Schedule no later than at the preconstruction conference, or some other mutually agreed upon submittal time. The schedule may be a critical path method (CPM) schedule, bar chart, or other standard schedule format. Regardless of which format used, the schedule shall identify the critical path. The Engineer will evaluate the Type A Progress Schedule and approve or return the schedule for corrections within 15 calendar days of receiving the submittal.

1-08.4 Prosecution of Work

Delete this section and replace it with the following:

1-08.4 Notice to Proceed and Prosecution of Work

(July 23, 2015 APWA GSP)

Notice to Proceed will be given after the contract has been executed and the contract bond and evidence of insurance have been approved and filed by the Contracting Agency. The

CITY OF FEDERAL WAY

SP-42

21ST AVE S & S 320TH STREET
SIGNALIZATION AND PEDESTRIAN
IMPROVEMENTS PROJECT
PROJECT #36225

Contractor shall not commence with the work until the Notice to Proceed has been given by the Engineer. The Contractor shall commence construction activities on the project site within ten days of the Notice to Proceed Date, unless otherwise approved in writing. The Contractor shall diligently pursue the work to the physical completion date within the time specified in the contract. Voluntary shutdown or slowing of operations by the Contractor shall not relieve the Contractor of the responsibility to complete the work within the time(s) specified in the contract.

When shown in the Plans, the first order of work shall be the installation of high visibility fencing to delineate all areas for protection or restoration, as described in the Contract. Installation of high visibility fencing adjacent to the roadway shall occur after the placement of all necessary signs and traffic control devices in accordance with 1-10.1(2). Upon construction of the fencing, the Contractor shall request the Engineer to inspect the fence. No other work shall be performed on the site until the Contracting Agency has accepted the installation of high visibility fencing, as described in the Contract.

(December 1, 2021 CFW GSP)

Section 1-08.4 is supplemented with the following.

The Contractor shall provide adequate equipment and forces to carry out the construction schedule to completion of the contract by the date specified.

1-08.5 Time for Completion

(December 30, 2022 APWA GSP, OPTION A)

Revise the third and fourth paragraphs to read:

Contract time shall begin on the first working day following the Notice to Proceed Date.

Each working day shall be charged to the contract as it occurs, until the contract work is physically complete. If substantial completion has been granted and all the authorized working days have been used, charging of working days will cease. Each week the Engineer will provide the Contractor a statement that shows the number of working days: (1) charged to the contract the week before; (2) specified for the physical completion of the contract; and (3) remaining for the physical completion of the contract. The statement will also show the nonworking days and any partial or whole day the Engineer declares as unworkable. The statement will be identified as a Written Determination by the Engineer. If the Contractor does not agree with the Written Determination of working days, the Contractor shall pursue the protest procedures in accordance with Section 1-04.5. By failing to follow the procedures of Section 1-04.5, the Contractor shall be deemed as having accepted the statement as correct. If the Contractor is approved to work 10 hours a day and 4 days a week (a 4-10 schedule) and the fifth day of the week in which a 4-10 shift is worked would ordinarily be charged as a working day then the fifth day of that week will be charged as a working day whether or not the Contractor works on that day.

Revise the sixth paragraph to read:

The Engineer will give the Contractor written notice of the completion date of the contract after all the Contractor's obligations under the contract have been performed by the Contractor. The following events must occur before the Completion Date can be established:

1. The physical work on the project must be complete; and

CITY OF FEDERAL WAY

SP-43

**21ST AVE S & S 320TH STREET
SIGNALIZATION AND PEDESTRIAN
IMPROVEMENTS PROJECT
PROJECT #36225**

2. The Contractor must furnish all documentation required by the contract and required by law, to allow the Contracting Agency to process final acceptance of the contract. The following documents must be received by the Project Engineer prior to establishing a completion date:
 - a. Certified Payrolls (per Section 1-07.9(5)).
 - b. Material Acceptance Certification Documents
 - c. Monthly Reports of Amounts Credited as DBE Participation, as required by the Contract Provisions.
 - d. Final Contract Voucher Certification
 - e. Copies of the approved "Affidavit of Prevailing Wages Paid" for the Contractor and all Subcontractors
 - f. A copy of the Notice of Termination sent to the Washington State Department of Ecology (Ecology); the elapse of 30 calendar days from the date of receipt of the Notice of Termination by Ecology; and no rejection of the Notice of Termination by Ecology. This requirement will not apply if the Construction Stormwater General Permit is transferred back to the Contracting Agency in accordance with Section 8-01.3(16).
 - g. Property owner releases per Section 1-07.24

(March 13, 1995 WSDOT GSP, OPTION 7)

Section 1-08.5 is supplemented with the following:

This project shall be physically complete within 140 working days.

1-08.6 Suspension of Work

(February 6, 2023 WSDOT GSP, OPTION 2)

Section 1-08.6 is supplemented with the following:

Contract time may be suspended for procurement of critical materials (Procurement Suspension). In order to receive a Procurement Suspension, the Contractor shall within 21 calendar days after execution by the Contracting Agency, place purchase orders for all materials deemed critical by the Contracting Agency for physical completion of the contract. The Contractor shall provide copies of purchase orders for the critical materials. Such purchase orders shall disclose the purchase order date and estimated delivery dates for such critical material.

The Contractor shall show procurement of the materials listed below as activities in the Progress Schedule. If the approved Progress Schedule indicates the materials procurement are critical activities, and if the Contractor has provided documentation that purchase orders are placed for the critical materials within the prescribed 21 calendar days, then contract time shall be suspended upon physical completion of all critical work except that work dependent upon the listed critical materials:

- * Signal Poles and Mast Arms

Charging of contract time will resume upon delivery of the critical materials to the Contractor or 90 calendar days after execution by the Contracting Agency, whichever occurs first.

CITY OF FEDERAL WAY

**21ST AVE S & S 320TH STREET
SIGNALIZATION AND PEDESTRIAN
IMPROVEMENTS PROJECT
PROJECT #36225**

SP-44

CFW SPECIAL PROVISIONS VER. 2023.06

1-08.9 Liquidated Damages
(March 3, 2021 APWA GSP, OPTION A)

Replace Section 1-08.9 with the following:

Time is of the essence of the Contract. Delays inconvenience the traveling public, obstruct traffic, interfere with and delay commerce, and increase risk to Highway users. Delays also cost tax payers undue sums of money, adding time needed for administration, engineering, inspection, and supervision.

Accordingly, the Contractor agrees:

1. To pay liquidated damages in the amount of \$1,750.00 for each working day beyond the number of working days established for Physical Completion, and
2. To authorize the Engineer to deduct these liquidated damages from any money due or coming due to the Contractor.

When the Contract Work has progressed to Substantial Completion as defined in the Contract, the Engineer may determine the Contract Work is Substantially Complete. The Engineer will notify the Contractor in writing of the Substantial Completion Date. For overruns in Contract time occurring after the date so established, liquidated damages identified above will not apply. For overruns in Contract time occurring after the Substantial Completion Date, liquidated damages shall be assessed on the basis of direct engineering and related costs assignable to the project until the actual Physical Completion Date of all the Contract Work. The Contractor shall complete the remaining Work as promptly as possible. Upon request by the Project Engineer, the Contractor shall furnish a written schedule for completing the physical Work on the Contract.

Liquidated damages will not be assessed for any days for which an extension of time is granted. No deduction or payment of liquidated damages will, in any degree, release the Contractor from further obligations and liabilities to complete the entire Contract.

1-09 MEASUREMENT AND PAYMENT

1-09.2(1) General Requirements for Weighing Equipment
(December 30, 2022 APWA GSP, OPTION 2)

Revise item 4 of the fifth paragraph to read:

4. Test results and scale weight records for each day's hauling operations are provided to the Engineer daily. Reporting shall utilize WSDOT form 422-027, Scaleman's Daily Report, unless the printed ticket contains the same information that is on the Scaleman's Daily Report Form. The scale operator must provide AM and/or PM tare weights for each truck on the printed ticket.

1-09.2(1)A1 Equipment
(March 9, 2023 WSDOT GSP)

Item number 1 in the first paragraph of Section 1-09.2(1)A1 is revised to read:

1. The ETS shall generate an E-ticket in PDF format meeting the requirements of 1-09.2(1)A2. The information shall be immediately uploaded to a designated site so the information can be accessed by the Inspector located at the material delivery site.

CITY OF FEDERAL WAY

SP-45

**21ST AVE S & S 320TH STREET
SIGNALIZATION AND PEDESTRIAN
IMPROVEMENTS PROJECT
PROJECT #36225**

CFW SPECIAL PROVISIONS VER. 2023.06

1-09.2(5) Measurement

(December 30, 2022 APWA GSP)

Revise the first paragraph to read:

Scale Verification Checks – At the Engineer’s discretion, the Engineer may perform verification checks on the accuracy of each batch, hopper, or platform scale used in weighing contract items of Work.

1-09.6 Force Account

(December 30, 2022 APWA GSP)

Supplement this section with the following:

The Contracting Agency has estimated and included in the Proposal, dollar amounts for all items to be paid per force account, only to provide a common proposal for Bidders. All such dollar amounts are to become a part of Contractor's total bid. However, the Contracting Agency does not warrant expressly or by implication, that the actual amount of work will correspond with those estimates. Payment will be made on the basis of the amount of work actually authorized by the Engineer.

1-09.7 Mobilization

(March 22, 2023 CFW GSP)

Supplement Section 1-09.7 with the following:

Obtaining a site for the Contractor’s mobilization, field office(s), storage of materials, access and personnel parking spaces, and other general operations shall be the responsibility of the Contractor. The Contractor will be responsible for maintaining these spaces in a safe and orderly condition throughout the duration of the project. The Contractor shall provide the City with a copy of agreement(s) with property owner. All costs associated with securing sites shall be included in the other bid items on the project and no other compensation will be made.

1-09.9 Payments

(December 30, 2022 APWA GSP)

Section 1-09.9 is revised to read:

The basis of payment will be the actual quantities of Work performed according to the Contract and as specified for payment.

The Contractor shall submit a breakdown of the cost of lump sum bid items at the Preconstruction Conference, to enable the Project Engineer to determine the Work performed on a monthly basis. A breakdown is not required for lump sum items that include a basis for incremental payments as part of the respective Specification. Absent a lump sum breakdown, the Project Engineer will make a determination based on information available. The Project Engineer’s determination of the cost of work shall be final.

Progress payments for completed work and material on hand will be based upon progress estimates prepared by the Engineer. A progress estimate cutoff date will be established at the preconstruction conference.

CITY OF FEDERAL WAY

**21ST AVE S & S 320TH STREET
SIGNALIZATION AND PEDESTRIAN
IMPROVEMENTS PROJECT
PROJECT #36225**

SP-46

CFW SPECIAL PROVISIONS VER. 2023.06

The initial progress estimate will be made not later than 30 days after the Contractor commences the work, and successive progress estimates will be made every month thereafter until the Completion Date. Progress estimates made during progress of the work are tentative, and made only for the purpose of determining progress payments. The progress estimates are subject to change at any time prior to the calculation of the final payment.

The value of the progress estimate will be the sum of the following:

1. Unit Price Items in the Bid Form — the approximate quantity of acceptable units of work completed multiplied by the unit price.
2. Lump Sum Items in the Bid Form — based on the approved Contractor's lump sum breakdown for that item, or absent such a breakdown, based on the Engineer's determination.
3. Materials on Hand — 100 percent of invoiced cost of material delivered to Job site or other storage area approved by the Engineer.
4. Change Orders — entitlement for approved extra cost or completed extra work as determined by the Engineer.

Progress payments will be made in accordance with the progress estimate less:

1. Retainage per Section 1-09.9(1), on non FHWA-funded projects;
2. The amount of progress payments previously made; and
3. Funds withheld by the Contracting Agency for disbursement in accordance with the Contract Documents.

Progress payments for work performed shall not be evidence of acceptable performance or an admission by the Contracting Agency that any work has been satisfactorily completed. The determination of payments under the contract will be final in accordance with Section 1-05.1.

Failure to perform obligations under the Contract by the Contractor may be decreed by the Contracting Agency to be adequate reason for withholding any payments until compliance is achieved.

Upon completion of all Work and after final inspection (Section 1-05.11), the amount due the Contractor under the Contract will be paid based upon the final estimate made by the Engineer and presentation of a Final Contract Voucher Certification to be signed by the Contractor. The Contractor's signature on such voucher shall be deemed a release of all claims of the Contractor unless a Certified Claim is filed in accordance with the requirements of Section 1-09.11 and is expressly excepted from the Contractor's certification on the Final Contract Voucher Certification. The date the Contracting Agency signs the Final Contract Voucher Certification constitutes the final acceptance date (Section 1-05.12).

If the Contractor fails, refuses, or is unable to sign and return the Final Contract Voucher Certification or any other documentation required for completion and final acceptance of the Contract, the Contracting Agency reserves the right to establish a Completion Date

CITY OF FEDERAL WAY

SP-47

**21ST AVE S & S 320TH STREET
SIGNALIZATION AND PEDESTRIAN
IMPROVEMENTS PROJECT
PROJECT #36225**

CFW SPECIAL PROVISIONS VER. 2023.06

(for the purpose of meeting the requirements of RCW 60.28) and unilaterally accept the Contract. Unilateral final acceptance will occur only after the Contractor has been provided the opportunity, by written request from the Engineer, to voluntarily submit such documents. If voluntary compliance is not achieved, formal notification of the impending establishment of a Completion Date and unilateral final acceptance will be provided by email with delivery confirmation from the Contracting Agency to the Contractor, which will provide 30 calendar days for the Contractor to submit the necessary documents. The 30 calendar day period will begin on the date the email with delivery confirmation is received by the Contractor. The date the Contracting Agency unilaterally signs the Final Contract Voucher Certification shall constitute the Completion Date and the final acceptance date (Section 1-05.12). The reservation by the Contracting Agency to unilaterally accept the Contract will apply to Contracts that are Physically Completed in accordance with Section 1-08.5, or for Contracts that are terminated in accordance with Section 1-08.10. Unilateral final acceptance of the Contract by the Contracting Agency does not in any way relieve the Contractor of their responsibility to comply with all Federal, State, tribal, or local laws, ordinances, and regulations that affect the Work under the Contract.

Payment to the Contractor of partial estimates, final estimates, and retained percentages shall be subject to controlling laws.

1-09.11(3) Time Limitation and Jurisdiction
(December 30, 2022 APWA GSP)

Revise this section to read:

For the convenience of the parties to the Contract it is mutually agreed by the parties that all claims or causes of action which the Contractor has against the Contracting Agency arising from the Contract shall be brought within 180 calendar days from the date of final acceptance (Section 1-05.12) of the Contract by the Contracting Agency; and it is further agreed that all such claims or causes of action shall be brought only in the Superior Court of the county where the Contracting Agency headquarters is located, provided that where an action is asserted against a county, RCW 36.01.050 shall control venue and jurisdiction. The parties understand and agree that the Contractor's failure to bring suit within the time period provided, shall be a complete bar to all such claims or causes of action. It is further mutually agreed by the parties that when claims or causes of action which the Contractor asserts against the Contracting Agency arising from the Contract are filed with the Contracting Agency or initiated in court, the Contractor shall permit the Contracting Agency to have timely access to all records deemed necessary by the Contracting Agency to assist in evaluating the claims or action.

1-09.13 Claim Resolution

1-09.13(1) General
(December 30, 2022 APWA GSP)

Revise this Section to read

Prior to seeking claims resolution through arbitration or litigation, the Contractor shall proceed in accordance with Sections 1-04.5 and 1-09.11. The provisions of Sections 1-04.5 and 1-09.11 must be complied with in full as a condition precedent to the Contractor's right to seek claim resolution through binding arbitration or litigation.

CITY OF FEDERAL WAY

**21ST AVE S & S 320TH STREET
SIGNALIZATION AND PEDESTRIAN
IMPROVEMENTS PROJECT
PROJECT #36225**

SP-48

CFW SPECIAL PROVISIONS VER. 2023.06

Any claims or causes of action which the Contractor has against the Contracting Agency arising from the Contract shall be resolved, as prescribed herein, through binding arbitration or litigation.

The Contractor and the Contracting Agency mutually agree that those claims or causes of action which total \$1,000,000 or less, which are not resolved by mediation, shall be resolved through litigation unless the parties mutually agree in writing to resolve the claim through binding arbitration.

The Contractor and the Contracting Agency mutually agree that those claims or causes of action in excess of \$1,000,000, which are not resolved by mediation, shall be resolved through litigation unless the parties mutually agree in writing to resolve the claim through binding arbitration.

1-09.13(3)A Arbitration General
(January 19, 2022 APWA GSP)

Revise the third paragraph to read:

The Contracting Agency and the Contractor mutually agree to be bound by the decision of the arbitrator, and judgment upon the award rendered by the arbitrator may be entered in the Superior Court of the county in which the Contracting Agency's headquarters is located, provided that where claims subject to arbitration are asserted against a county, RCW 36.01.050 shall control venue and jurisdiction of the Superior Court. The decision of the arbitrator and the specific basis for the decision shall be in writing. The arbitrator shall use the Contract as a basis for decisions.

1-09.13(4) Venue for Litigation
(December 30, 2022 APWA GSP)

Revise this section to read:

Litigation shall be brought in the Superior Court of the county in which the Contracting Agency's headquarters is located, provided that where claims are asserted against a county, RCW 36.01.050 shall control venue and jurisdiction of the Superior Court. It is mutually agreed by the parties that when litigation occurs, the Contractor shall permit the Contracting Agency to have timely access to all records deemed necessary by the Contracting Agency to assist in evaluating the claims or action.

1-10 TEMPORARY TRAFFIC CONTROL

1-10.1 General

1-10.1(2) Description
(April 12, 2018 CFW GSP)

Section 1-10.1(2) is supplemented with the following:

Business Open During Construction Signs

The Contractor shall provide a "Business Open During Construction" sign at every non-residential driveway approach within the project limits. Business Open During Construction Signs shall be considered Construction Signs Class A.

CITY OF FEDERAL WAY

SP-49

21ST AVE S & S 320TH STREET
SIGNALIZATION AND PEDESTRIAN
IMPROVEMENTS PROJECT
PROJECT #36225

City of Federal Way Project Signs

City of Federal Way Project signs shall be considered Construction Signs Class A. The Contractor shall provide two (2) project signs (4' x 8') per the detail available from the City.

1-10.2 Traffic Control Management

(November 2, 2022 WSDOT GSP, OPTION 1)

Section 1-10.2 is supplemented with the following:

Work Zone Safety Contingency

Enhancements to improve the effectiveness of the accepted traffic control plans to increase the safety of the work zones shall be discussed on a weekly basis between the Contractor and the Contracting Agency. Enhancements shall be mutually agreed upon by the Contractor and Engineer prior to performing any Work to implement the enhancement.

Enhancements do not include the use of Uniformed Police Officers or WSP, address changes to the allowed work hour restrictions, or changes to the staging plans in the Contract (if applicable). If allowed by the Engineer, these items will be addressed in accordance with Section 1-04.4.

The Contractor shall be solely responsible for submitting any traffic control plan revision to implement the enhancement in accordance with Section 1-10.2(2).

1-10.2(1) General

(October 3, 2022 WSDOT GSP, OPTION 1)

Section 1-10.2(1) is supplemented with the following:

The Traffic Control Supervisor shall be certified by one of the following:

The Northwest Laborers-Employers Training Trust
27055 Ohio Ave.
Kingston, WA 98346
(360) 297-3035
<https://www.nwlett.edu>

Evergreen Safety Council
12545 135th Ave. NE
Kirkland, WA 98034-8709
1-800-521-0778
<https://www.esc.org>

The American Traffic Safety Services Association
15 Riverside Parkway, Suite 100
Fredericksburg, Virginia 22406-1022
Training Dept. Toll Free (877) 642-4637
Phone: (540) 368-1701
<https://altssa.com/training>

Integrity Safety
13912 NE 20th Ave

CITY OF FEDERAL WAY

**21ST AVE S & S 320TH STREET
SIGNALIZATION AND PEDESTRIAN
IMPROVEMENTS PROJECT
PROJECT #36225**

SP-50

CFW SPECIAL PROVISIONS VER. 2023.06

Vancouver, WA 98686
(360) 574-6071
<https://www.integritysafety.com>

US Safety Alliance
(904)705-5660
<https://www.ussafetyalliance.com>

K&D Services Inc.
2719 Rockefeller Ave.
Everett, WA 98201
(800) 343-4049
<https://www.kndservices.net>

1-10.2(2) Traffic Control Plans
(April 12, 2018 CFW GSP)

Section 1-10.2(2) is supplemented with the following:

The following minimum Traffic Control requirements shall be maintained during the construction of the project:

1. If the Contractor opts to utilize traffic control plans other than those provided in these Contract Documents, the Contractor shall provide traffic control plans to the City of Federal Way for review and approval a minimum of five (5) working days prior to implementation. These plans shall supplement Construction Staging Plans. The plans as provided by the Contractor shall include and not be limited to the following information:
 - Stop line locations with station and offset to verify safety of intersection turning radius for vehicles.
 - Minimum lane widths provided for vehicular travel.
 - Turn pocket length, gap, and tapers in conformance with the City of Federal Way Standard Detail DWG 3-19A.
2. Detours will not be allowed except as noted herein or Section 1-07.23(2) as amended.
3. Temporary paint striping, reflective marking tape, and/or retroreflective tubular markers shall be required for each shift of traffic control. The Contractor shall provide temporary striping, reflective marking tape, and/or reflective tubular markers as required at the direction of the Engineer.
4. The Contractor provided Traffic Control Plans shall lay out traffic control device spacing, tapers, etc., to scale, and shall contain accurate dimensions and legends and shall be signed by the preparer.

1-10.3 Traffic Control Labor, Procedures and Devices

1-10.3(1)C Signalized Intersection Traffic Control
(September 3, 2021 CFW GSP)

Section 1-10.3(1)C is a new section:

CITY OF FEDERAL WAY

SP-51

**21ST AVE S & S 320TH STREET
SIGNALIZATION AND PEDESTRIAN
IMPROVEMENTS PROJECT
PROJECT #36225**

CFW SPECIAL PROVISIONS VER. 2023.06

Signalized Intersection Traffic Control is required when a signal system is in flashing mode, or is not operational. Signalized intersection traffic may not be flagged with an active signal in full operation.

Placing a signalized intersection into flash mode requires an approved traffic control plan. Additionally, the days/times that a signal is placed into flash mode must be pre-approved by the City. The signal should only be switched into flash mode by the City. The type of work that requires signals to be placed into flash mode may include, but is not limited to: installation of signal poles, signal switchover, paving, striping, or excavation in the intersection.

The Contractor shall minimize the limits of the work zone area at intersections whenever possible in order to avoid having the signal be placed into flash mode.

Signalized Intersection Traffic Control Labor shall conform to WAC 468-95-302 and approved traffic control plans.

If flaggers are utilized to provide traffic control of signalized intersections:

- At least two flaggers are required to flag from the center of the intersection, in addition to a flagger controlling each leg of the intersection.

If off-duty Uniformed Police Officers are utilized to provide traffic control of signalized intersections:

- A uniformed police officer (UPO) is a sworn police officer from a local law enforcement agency or a Washington State Patrol officer.
- Off-duty uniformed police officers must have a marked police vehicle with them on the project site. Unmarked police vehicles or personal vehicles are not acceptable.
- There is currently no availability of UPO's from the City of Federal Way Police Department. Many other law enforcement agencies also have little to no availability of off-duty officers. No other agencies or private companies are authorized to perform off-duty work within the City without project-specific approval from the Federal Way Police Chief or his designee. If the Contractor is able to procure a UPO from another law enforcement agency that is acceptable to the Federal Way Chief of Police, a change order will be required to add a bid item for "Contractor Provided Off-Duty Uniformed Police Officer".

1-10.4 Measurement

1-10.4(2) Item Bids with Lump Sum for Incidentals **(August 2, 2004 WSDOT GSP, OPTION 1)**

Section 1-10.4(2) is supplemented with the following:

The proposal does not contain the item "Project Temporary Traffic Control", lump sum. The provisions of Section 1-10.4(2) shall apply.

1-10.5 Payment

1-10.5(2) Item Bids with Lump Sum for Incidentals

CITY OF FEDERAL WAY

SP-52

21ST AVE S & S 320TH STREET
SIGNALIZATION AND PEDESTRIAN
IMPROVEMENTS PROJECT
PROJECT #36225

(November 2, 2022 WSDOT GSP, OPTION 7)

Section 1-10.5(2) is supplemented with the following:
“Work Zone Safety Contingency”, by force account.

All costs as authorized by the Engineer will be paid for by force account as specified in Section 1-09.6.

For purpose of providing a common proposal for all bidders, the Contracting Agency has entered an amount for the item “Work Zone Safety Contingency” in the Proposal to become a part of the Contractor’s total bid.

The Engineer may choose to use existing bid items for the implementation of the agreed upon enhancement.

END OF DIVISION 1

CITY OF FEDERAL WAY

**21ST AVE S & S 320TH STREET
SIGNALIZATION AND PEDESTRIAN
IMPROVEMENTS PROJECT
PROJECT #36225**

SP-53

CFW SPECIAL PROVISIONS VER. 2023.06

DIVISION 2 EARTHWORK

2-01 CLEARING, GRUBBING, AND ROADSIDE CLEANUP

2-01.1 Description

(March 13, 1995 WSDOT GSP, OPTION 1)

Section 2-01.1 is supplemented with the following:

Clearing and grubbing on this project shall be performed within the following limits:

Limits for clearing & grubbing shall be as shown on the plans. Clearing shall include removal of trees as noted on the plans or as directed by the Engineer to accommodate the improvements. Tree removal shall include removal of stumps and/or grinding of stumps to a depth at least two feet below finish grade.

2-01.3 Construction Requirements

2-01.3(3) Clearing Limit Fence

(April 12, 2018 CFW GSP)

Section 2-01.3(3) is a new section:

Clearing limit fence shall be 4-feet high, orange, high density polyethylene fencing with mesh openings 1½-inch by 3-inches nominal and weigh at least 7 oz. per linear foot. Either wood or steel posts shall be used. Wood posts shall have minimum dimensions of 1½ inches by 1½ inches by the minimum length of 5 feet, and shall be free of knots, splits, or gouges. Steel posts shall consist of either size No. 6 rebar or larger, ASTM A 120 steel pipe with a minimum diameter of 1 inch, U, T, L or C shape steel posts with a minimum weight of 1.35 lbs./ft. or other steel posts having equivalent strength and bending resistance to the post sizes listed. The spacing of the support posts shall be a maximum of 6½ feet.

2-01.3(4) Roadside Cleanup

(January 5, 1998 WSDOT GSP, OPTION 1)

Section 2-01.3(4) is supplemented with the following:

The Contractor shall restore, repair or correct all portions of the roadside or adjacent landscapes that were unavoidably damaged due to the performance or installation of the specified work. Unavoidable damage shall be determined only by the Engineer. All materials utilized shall be in accordance with Sections 9-14 and 9-15 and other applicable sections of the Standard Specifications or Special Provisions, whichever may apply. All work shall be performed in accordance with Sections 8-02 and 8-03 and other applicable sections of the Standard Specifications. The Contractor shall review the work with the Engineer and receive approval to proceed prior to commencing the work.

2-01.4 Measurement

(April 12, 2018 CFW GSP)

Section 2-01.4 is supplemented with the following:

“Clearing and Grubbing” will be measured on a lump sum basis. Installation, maintenance, and removal of the Clearing Limit Fence shall be included in the Clearing and Grubbing bid item.

CITY OF FEDERAL WAY

21ST AVE S & S 320TH STREET
SIGNALIZATION AND PEDESTRIAN
IMPROVEMENTS PROJECT
PROJECT #36225

SP-54

CFW SPECIAL PROVISIONS VER. 2023.06

“Roadside Cleanup”, will be measured by force account.

2-01.5 Payment

(April 12, 2018 CFW GSP)

Section 2-01.5 is supplemented with the following:

“Clearing and Grubbing”, lump sum.

“Roadside Cleanup”, force account.

2-02 REMOVAL OF STRUCTURES AND OBSTRUCTIONS

2-02.3 Construction Requirements

(September 7, 2021 WSDOT GSP, OPTION 1)

Section 2-02.3 is supplemented with the following:

Removal of Obstructions

The following miscellaneous Obstructions shall be removed and disposed of:

ITEMS TO BE REMOVED INCLUDE, BUT IS NOT LIMITED TO, THE FOLLOWING: ^{1, 2}		
STATION / OFFSET	ITEM DESCRIPTION	QUANTITY
10.52, 58' LT to 10+60, 76' LT	Remove Curb Wall	21 LF
11+43, 75' RT to 11+81, 54' RT	Remove Curb Wall	14 EA
ITEMS TO BE SALVAGED TO THE CITY INCLUDE, BUT IS NOT LIMITED TO, THE FOLLOWING:		
<i>The above list of items to be removed and disposed of is provided for the convenience of the contractor. The contractor shall review the plans, specifications, and project site to verify other items to be removed.</i>		
<i>² Removal of pavements, curbs, sidewalks, concrete, and driveway approaches are included in the “Roadway Excavation Incl. Haul” bid item.</i>		

(October 4, 2021 WSDOT GSP, OPTION 5)

Section 2-02.3 is supplemented with the following:

Removal and Disposal of Asbestos Material

In the event suspected Asbestos Containing Material (ACM) is encountered, the Contractor shall immediately notify the Engineer and the provisions of Section 1-04.7 shall apply. Prior to commencing asbestos related work, the Contractor shall obtain all permits from and provide notification to, the Washington State Department of Labor and Industries, the Washington State Department of Ecology, the local clean air agency, and other permitting and regulatory agencies with jurisdiction over the work involving asbestos as the laws, rules, and regulations require.

The ACM shall only be disturbed under the supervision of a Washington State Certified Asbestos Supervisor (CAS). The CAS shall be certified in accordance with WAC 295-65-012.

CITY OF FEDERAL WAY

21ST AVE S & S 320TH STREET
SIGNALIZATION AND PEDESTRIAN
IMPROVEMENTS PROJECT
PROJECT #36225

SP-55

The CAS shall supervise the asbestos removal and ensure that the handling and removal of asbestos is accomplished by certified asbestos workers and in accordance with Washington State Department of Labor and Industries standards. The Contractor shall ensure that the removal and disposal of asbestos meets the requirements of EPA regulation 40 CFR Part 61, local health department regulations, and all other applicable regulations.

No asbestos is expected to be encountered. However, if the Contractor believes they have encountered asbestos, they shall immediately notify the Engineer in accordance with Section 1-04.7.

2-02.3(3) Removal of Pavement, Sidewalks, Curbs, and Gutters
(April 12, 2018 CFW GSP)

Section 2-02.3(3) is supplemented with the following:

Prior to removal of pavement, the Contractor shall make a full-depth sawcut to delineate the areas of pavement removal from those areas of pavement to remain. The Engineer shall approve the equipment and procedures used to make the full-depth sawcut. No wastewater from the sawcutting operation shall be released directly to any stream or storm sewer system.

(December 1, 2021 CFW GSP)

Section 2-02.3(3) is supplemented with the following:

Removal of pavement, curbs, gutters, and sidewalks within the entire project limits shall be measured and paid as "Roadway Excavation incl. Haul" in accordance with Section 2-03.

2-02.3(5) Adjust Existing Utility to Grade
(April 12, 2018 CFW GSP)

2-02.3(5) is a new section:

As shown in the Plans, existing utilities such as monuments, manholes, catch basin frames and grates, water valves, and meter boxes shall be adjusted to finished grade. The Contractor shall, prior to the beginning of any work, familiarize himself with the existing utility locations. The Contractor shall adjust City-owned utilities. Final adjustment shall be smooth and flush with finished grade. The Contractor shall mark the location of all utilities prior to paving the new surface. Unless otherwise provided for in the Special Provisions and Proposal, costs for adjusting utilities to grade, including coordinating the work with other utilities, shall be incidental to the various items of work and no additional compensation will be allowed.

Existing facilities shall be adjusted to the finished grade as shown in the Drawings and as further specified herein. Existing box, ring, grate, and cover shall be reset in a careful and workmanlike manner to conform to the new grade. Special care shall be exercised in all operations. Any damage occurring to the manholes, concrete inlets, monument cases, valve boxes, or water mains, due to the Contractor's operations, shall be repaired at the Contractor's own expense. Adjustments shall be made using bricks, concrete blocks, or cement, and the interior of the manhole adjustment shall be mortared smoothly. All covers and frames shall be thoroughly cleaned. The Contractor shall be responsible for

CITY OF FEDERAL WAY

21ST AVE S & S 320TH STREET
SIGNALIZATION AND PEDESTRIAN
IMPROVEMENTS PROJECT
PROJECT #36225

SP-56

CFW SPECIAL PROVISIONS VER. 2023.06

referencing and keeping a record of such references of all manholes, catch basins, monument cases, meter boxes, and valve boxes encountered, and shall submit a copy of these references to the Engineer.

The manholes, catch basins, monument cases, meter boxes, and valve boxes shall be adjusted to grade in accordance with Section 1-05.3(1). Final restoration of finished grade surfaces shall be performed in the following manner:

1. Within a Gravel Surface: Provide a 6-inch-deep and 6-inch-wide concrete collar installed and restored with 3 inches of crushed surfacing top course.
2. Within a Grass Surface: Provide crushed surfacing top course backfill and 3 inches of Topsoil Type A, and seed.
3. Within an Asphalt Cement Concrete Paved Surface: See City standard detail for Utility Adjustment.

2-02.4 Vacant

(December 1, 2021 CFW GSP)

Section 2-02.4 Vacant shall be deleted and replaced with the following:

2-02.5 Payment

(December 1, 2021 CFW GSP)

Section 2-02.5 is supplemented with the following:

Payment will be made in accordance with Section 1-04.1 for the following bid items when included in the proposal:

“Removal of Structure and Obstruction”, lump sum. Structure Excavation Class B for the removal of items shall be considered included in this bid item.

2-03 ROADWAY EXCAVATION AND EMBANKMENT

2-03.2 Pavement Removal

(April 12, 2018 CFW GSP)

Section 2-03.2 is replaced with the following:

Where shown in the Plans or where designated by the Engineer, the Contractor shall remove asphalt, concrete, Portland cement concrete pavement, sidewalks and curbs.

Prior to removal, the Contractor shall make a full-depth sawcut to delineate the areas of pavement removal from those areas of pavement to remain. The Engineer shall approve the equipment and procedures used to make the full-depth sawcut. No wastewater from the sawcutting operation shall be released directly to any stream or storm sewer system. Alternatively, the Contractor may elect grinding for pavement removal, where appropriate.

The removed pavement shall become the property of the Contractor and shall be removed from the project. Damage caused to portions of the pavement to remain, due to the Contractor's operation, shall be repaired by the Contractor at the Contractor's expense and to the satisfaction of the Engineer.

Removal of pavement, sidewalks, curbs, and gutters throughout the project shall be measured and paid as “Roadway Excavation Incl. Haul” and no additional payment will be made.

CITY OF FEDERAL WAY

**21ST AVE S & S 320TH STREET
SIGNALIZATION AND PEDESTRIAN
IMPROVEMENTS PROJECT
PROJECT #36225**

SP-57

CFW SPECIAL PROVISIONS VER. 2023.06

2-03.3 Construction Requirements

Section 2-03.3(10) Selected Material

(April 12, 2018 CFW GSP)

Section 2-03.3(10) is supplemented with the following:

Selected Material when specified or required by the Engineer for use on the project shall meet the requirements of specified in Section 9-03.14(3) for Common Borrow.

Section 2-03.3(14)E Unsuitable Foundation Excavation

(August 27, 2021 CFW GSP)

Section 2-03.3(14)E is supplemented with the following:

All embankments shall be founded on dense, non-yielding granular foundation soil as approved by the engineer. Remove all organic materials and debris, trash, or other deleterious material prior to beginning construction of new embankments. Proof roll the foundation.

Section 2-03.3(14)G Backfilling

(April 12, 2018 CFW GSP)

Section 2-03.3(14)G is supplemented with the following:

Remove all water and non-compatible materials from excavations prior to backfilling or attempting to compact embankment soil. Place native soils or provide import Gravel Borrow as required to complete the work. Backfill all embankments in accordance with 2-03.3(14)C, Compacting Earth Embankments, Method C.

Section 2-03.3(14)N Wet Weather Earthwork

(April 12, 2018 CFW GSP)

Section 2-03.3(14)N is a new section:

Earthwork completed in wet weather or under wet conditions shall be accomplished in small sections to minimize exposure to wet weather. Each section shall be sufficiently small so that the removal of soil and placement of backfill can be accomplished on the same day. No soil shall be left un-compacted and exposed to water. Soil that is too wet for compaction shall be removed and replaced with Gravel Borrow material. Grading and earthwork should not be accomplished during periods of heavy continuous rainfall.

2-03.4 Measurement

(March 13, 1995 WSDOT GSP, OPTION 2)

Section 2-03.4 is supplemented with the following:

Only one determination of the original ground elevation will be made on this project. Measurement for roadway excavation and embankment will be based on the original ground elevations recorded previous to the award of this contract.

If discrepancies are discovered in the ground elevations, which will materially affect the quantities of earthwork, the original computations of earthwork quantities will be adjusted accordingly.

Earthwork quantities will be computed, either manually or by means of electronic data processing equipment, by use of the average end area method or by the finite element analysis method utilizing digital terrain modeling techniques.

CITY OF FEDERAL WAY

21ST AVE S & S 320TH STREET
SIGNALIZATION AND PEDESTRIAN
IMPROVEMENTS PROJECT
PROJECT #36225

SP-58

CFW SPECIAL PROVISIONS VER. 2023.06

Copies of the ground cross-section notes will be available for the bidder's inspection, before the opening of bids, at the Engineer's office and at the Region office.

Upon award of the contract, copies of the original ground cross-sections will be furnished to the successful bidder on request to the Engineer.

(April 12, 2018 CFW GSP)

Section 2-03.4 is supplemented with the following:

If the Contractor excavates outside the neat-line limits designated for "Roadway Excavation, Incl. Haul" or performs extra excavation, it shall be considered for the Contractor's benefit and shall be included in the cost of other Bid Items.

2-03.5 Payment

(April 12, 2018 CFW GSP)

Section 2-03.5 is supplemented with the following:

Payment will be made in accordance with Section 1-04.1 for the following bid items when included in the proposal:

"Roadway Excavation Incl. Haul", per cubic yard.

(March 13, 1995 WSDOT GSP, OPTION 2)

Section 2-03.5 is supplemented with the following:

All costs in connection with the preparation of waste sites and waste deposits shall be included in the Mobilization.

2-09 STRUCTURE EXCAVATION

2-09.3 Construction Requirements

2-09.3(1) General Requirements

(March 22, 2023 CFW GSP)

Section 2-09.3(1) is supplemented with the following:

All shoring, including sheeting and bracing, or equivalent trench stabilization and worker protection system required to perform and protect the excavation, and to safeguard the personnel who may enter the excavation, shall be furnished by the Contractor. If workers enter any trench or other excavation four feet (4') or more in depth that does not meet the open pit requirements as generally set forth in Section 2-09.3(3)B, it shall be shored.

The Contractor alone shall be responsible for worker safety, and the Contracting Agency assumes no responsibility therefore.

Upon completing the Work, the Contractor shall remove all shoring, unless otherwise shown in the Plans or directed by the Engineer.

The Contractor is advised that the Contracting Agency has not so delegated, and the Engineer does not purport to be, a trench excavation system safety expert, is not so engaged in that capacity under this Contract, and has neither the authority nor the responsibility to enforce construction safety laws, rules, regulations, or

CITY OF FEDERAL WAY

**21ST AVE S & S 320TH STREET
SIGNALIZATION AND PEDESTRIAN
IMPROVEMENTS PROJECT
PROJECT #36225**

SP-59

CFW SPECIAL PROVISIONS VER. 2023.06

procedures, or to order the suspension of work for claimed violations of trench excavation safety.

The furnishing by the Contracting Agency of resident project representation and inspection shall not make the Contracting Agency responsible for the enforcement of such laws, rules, regulations, or procedures, nor shall such make the Contracting Agency responsible for construction means, methods, techniques, sequences, procedures, or for the Contractor's failure to properly perform the Work necessary for proper trench excavation.

2-09.3(1)D Disposal of Excavated Material
(March 17, 2020 CFW GSP)

Replace the third paragraph with the following:

If the Contract includes Structure Excavation, Class A or B, including haul; Shoring or Extra Excavation, Class A or B; or Trench Safety System, the unit contract price shall include all costs for loading and hauling excavated materials to a permitted disposal site, or to and from a temporary stockpile. Any such stockpiled materials, either suitable or designated for incorporation into the project, shall be handled in accordance with Section 2-09.3(1)E.

2-09.3(1)E Backfilling
(April 12, 2018 CFW GSP)

The first paragraph of Section 2-09.3(1) is replaced with the following:

The backfilling of openings dug for Structures or for Removal of Structures and Obstructions shall be a necessary part of and incidental to the excavation. Backfill material shall be Gravel Borrow unless the use of native or other material is approved by the engineer.

2-09.5 Payment
(March 17, 2020 CFW GSP)

Replace the fourteenth paragraph with the following:

The unit contract price per square foot for "Shoring or Extra Excavation Class B" shall be full pay for furnishing, placing, moving, and removing temporary shoring, or equivalent trench stabilization and worker protection system, and for all excavation, backfill, compact, and other work required when extra excavation is used in lieu of such temporary shoring or equivalent trench safety system. If select backfill material is required for backfilling within the limits of the excavation, it shall also be required as backfill material for the extra excavation at the Contractor's expense.

END OF DIVISION 2

CITY OF FEDERAL WAY

**21ST AVE S & S 320TH STREET
SIGNALIZATION AND PEDESTRIAN
IMPROVEMENTS PROJECT
PROJECT #36225**

SP-60

CFW SPECIAL PROVISIONS VER. 2023.06

**DIVISION 3
AGGREGATE PRODUCTION AND ACCEPTANCE**

3-01 PRODUCTION FROM QUARRY AND PIT SITES

3-01.4 Contractor Furnished Material Sources

3-01.4(1) Acquisition and Development

(April 12, 2018 CFW GSP)

Section 3-01.4(1) is supplemented with the following:

No source has been provided for any materials necessary for the construction of these improvements.

If the source of material provided by the Contractor necessitates hauling over roads other than City streets, the Contractor shall, at his own cost and expense, make all arrangements for the use of haul routes.

END OF DIVISION 3

CITY OF FEDERAL WAY

**21ST AVE S & S 320TH STREET
SIGNALIZATION AND PEDESTRIAN
IMPROVEMENTS PROJECT
PROJECT #36225**

SP-61

CFW SPECIAL PROVISIONS VER. 2023.06

***** PLAN CENTER COPY *** Official bid documents, plan holder's list, and addenda (if applicable) are available on BXWA.com**

DIVISION 4 BASES

4-04 BALLAST AND CRUSHED SURFACING

4-04.3 Construction Requirements

4-04.3(3) Mixing

(April 12, 2018 CFW GSP)

Item 2 of Section 4-04.3(3), is replaced with the following:

2. **Road Mix Method** - The road mix method of mixing surfacing material will not be allowed.

4-04.3(4) Placing and Spreading

(April 12, 2018 CFW GSP)

Item 2 of Section 4-04(4), is replaced with the following:

2. **Road Mix Method** - The road mix method of mixing surfacing material will not be allowed.

4-04.5 Payment

(December 1, 2021 CFW GSP)

Section 4-04.5 is supplemented with the following:

The unit contract price for Ballast and Crushed Surfacing and Maintenance Rock shall also include compacting, spreading, and removing and hauling to waste when required by the Engineer.

END OF DIVISION 4

CITY OF FEDERAL WAY

21ST AVE S & S 320TH STREET
SIGNALIZATION AND PEDESTRIAN
IMPROVEMENTS PROJECT
PROJECT #36225

SP-62

CFW SPECIAL PROVISIONS VER. 2023.06

*** PLAN CENTER COPY *** Official bid documents, plan holder's list, and addenda (if applicable) are available on BXWA.com

DIVISION 5 SURFACE TREATMENTS AND PAVEMENTS

5-04 HOT MIX ASPHALT ***(July 18, 2018 APWA GSP)***

Delete Section 5-04 and amendments, Hot Mix Asphalt and replace it with the following:

5-04.1 Description

This Work shall consist of providing and placing one or more layers of plant-mixed hot mix asphalt (HMA) on a prepared foundation or base in accordance with these Specifications and the lines, grades, thicknesses, and typical cross-sections shown in the Plans. The manufacture of HMA may include warm mix asphalt (WMA) processes in accordance with these Specifications. WMA processes include organic additives, chemical additives, and foaming.

HMA shall be composed of asphalt binder and mineral materials as may be required, mixed in the proportions specified to provide a homogeneous, stable, and workable mixture.

5-04.2 Materials

Materials shall meet the requirements of the following sections:

Asphalt Binder	9-02.1(4)
Cationic Emulsified Asphalt	9-02.1(6)
Anti-Stripping Additive	9-02.4
HMA Additive	9-02.5
Aggregates	9-03.8
Recycled Asphalt Pavement	9-03.8(3)B
Mineral Filler	9-03.8(5)
Recycled Material	9-03.21
Portland Cement	9-01
Sand	9-03.1(2)
(As noted in 5-04.3(5)C for crack sealing)	
Joint Sealant	9-04.2
Foam Backer Rod	9-04.2(3)A

The Contract documents may establish that the various mineral materials required for the manufacture of HMA will be furnished in whole or in part by the Contracting Agency. If the documents do not establish the furnishing of any of these mineral materials by the Contracting Agency, the Contractor shall be required to furnish such materials in the amounts required for the designated mix. Mineral materials include coarse and fine aggregates, and mineral filler.

The Contractor may choose to utilize recycled asphalt pavement (RAP) in the production of HMA. The RAP may be from pavements removed under the Contract, if any, or pavement material from an existing stockpile.

The Contractor may use up to 20 percent RAP by total weight of HMA with no additional sampling or testing of the RAP. The RAP shall be sampled and tested at a frequency of one sample for every 1,000 tons produced and not less than ten samples per project. The asphalt content and gradation test data shall be reported to the Contracting Agency when submitting the mix design for approval on the QPL. The Contractor shall include the RAP as part of the mix design as defined in these Specifications.

CITY OF FEDERAL WAY

**21ST AVE S & S 320TH STREET
SIGNALIZATION AND PEDESTRIAN
IMPROVEMENTS PROJECT
PROJECT #36225**

SP-63

CFW SPECIAL PROVISIONS VER. 2023.06

*** PLAN CENTER COPY *** Official bid documents, plan holder's list, and addenda (if applicable) are available on BXWA.com

The grade of asphalt binder shall be as required by the Contract. Blending of asphalt binder from different sources is not permitted.

The Contractor may only use warm mix asphalt (WMA) processes in the production of HMA with 20 percent or less RAP by total weight of HMA. The Contractor shall submit to the Engineer for approval the process that is proposed and how it will be used in the manufacture of HMA.

Production of aggregates shall comply with the requirements of Section 3-01.

Preparation of stockpile site, the stockpiling of aggregates, and the removal of aggregates from stockpiles shall comply with the requirements of Section 3-02.

5-04.2(1) How to Get an HMA Mix Design on the QPL

If the contractor wishes to submit a mix design for inclusion in the Qualified Products List (QPL), please follow the WSDOT process outlined in Standard Specification 5-04.2(1).

5-04.2(1)A Vacant

5-04.2(2) Mix Design – Obtaining Project Approval

No paving shall begin prior to the approval of the mix design by the Engineer.

Nonstatistical evaluation will be used for all HMA not designated as Commercial HMA in the contract documents.

Commercial evaluation will be used for Commercial HMA and for other classes of HMA in the following applications: sidewalks, road approaches, ditches, slopes, paths, trails, gores, prelevel, and pavement repair. Other nonstructural applications of HMA accepted by commercial evaluation shall be as approved by the Project Engineer. Sampling and testing of HMA accepted by commercial evaluation will be at the option of the Project Engineer. The Proposal quantity of HMA that is accepted by commercial evaluation will be excluded from the quantities used in the determination of nonstatistical evaluation.

Nonstatistical Mix Design. Fifteen days prior to the first day of paving the contractor shall provide one of the following mix design verification certifications for Contracting Agency review;

- The WSDOT Mix Design Evaluation Report from the current WSDOT QPL, or one of the mix design verification certifications listed below.
- The proposed HMA mix design on WSDOT Form 350-042 with the seal and certification (stamp & signature) of a valid licensed Washington State Professional Engineer.
- The Mix Design Report for the proposed HMA mix design developed by a qualified City or County laboratory that is within one year of the approval date.**

The mix design shall be performed by a lab accredited by a national authority such as Laboratory Accreditation Bureau, L-A-B for Construction Materials Testing, The Construction Materials Engineering Council (CMEC's) ISO 17025 or AASHTO

CITY OF FEDERAL WAY

**21ST AVE S & S 320TH STREET
SIGNALIZATION AND PEDESTRIAN
IMPROVEMENTS PROJECT
PROJECT #36225**

SP-64

CFW SPECIAL PROVISIONS VER. 2023.06

*** PLAN CENTER COPY *** Official bid documents, plan holder's list, and addenda (if applicable) are available on BXWA.com

Accreditation Program (AAP) and shall supply evidence of participation in the AASHTO: resource proficiency sample program.

Mix designs for HMA accepted by Nonstatistical evaluation shall;

- Have the aggregate structure and asphalt binder content determined in accordance with WSDOT Standard Operating Procedure 732 and meet the requirements of Sections 9-03.8(2), except that Hamburg testing for ruts and stripping are at the discretion of the Engineer, and 9-03.8(6).
- Have anti-strip requirements, if any, for the proposed mix design determined in accordance with AASHTO T 283 or T 324, or based on historic anti-strip and aggregate source compatibility from previous WSDOT lab testing.

At the discretion of the Engineer, agencies may accept verified mix designs older than 12 months from the original verification date with a certification from the Contractor that the materials and sources are the same as those shown on the original mix design.

Commercial Evaluation Approval of a mix design for “Commercial Evaluation” will be based on a review of the Contractor’s submittal of WSDOT Form 350-042 (For commercial mixes, AASHTO T 324 evaluation is not required) or a Mix Design from the current WSDOT QPL or from one of the processes allowed by this section. Testing of the HMA by the Contracting Agency for mix design approval is not required.

For the Bid Item Commercial HMA, the Contractor shall select a class of HMA and design level of Equivalent Single Axle Loads (ESAL’s) appropriate for the required use.

5-04.2(2)B Using Warm Mix Asphalt Processes

The Contractor may elect to use additives that reduce the optimum mixing temperature or serve as a compaction aid for producing HMA. Additives include organic additives, chemical additives and foaming processes. The use of Additives is subject to the following:

- Do not use additives that reduce the mixing temperature more than allowed in Section 5-04.3(6) in the production of mixtures.
- Before using additives, obtain the Engineer’s approval using WSDOT Form 350-076 to describe the proposed additive and process.

5-04.3 Construction Requirements

5-04.3(1) Weather Limitations

Do not place HMA for wearing course on any Traveled Way beginning October 1st through March 31st of the following year without written concurrence from the Engineer.

Do not place HMA on any wet surface, or when the average surface temperatures are less than those specified below, or when weather conditions otherwise prevent the proper handling or finishing of the HMA.

Minimum Surface Temperature for Paving

Compacted Thickness (Feet)	Wearing Course	Other Courses
----------------------------	----------------	---------------

CITY OF FEDERAL WAY

**21ST AVE S & S 320TH STREET
SIGNALIZATION AND PEDESTRIAN
IMPROVEMENTS PROJECT
PROJECT #36225**

SP-65

Less than 0.10	55°F	45°F
0.10 to .20	45°F	35°F
More than 0.20	35°F	35°F

5-04.3(2) Paving Under Traffic

When the Roadway being paved is open to traffic, the requirements of this Section shall apply.

The Contractor shall keep intersections open to traffic at all times except when paving the intersection or paving across the intersection. During such time, and provided that there has been an advance warning to the public, the intersection may be closed for the minimum time required to place and compact the mixture. In hot weather, the Engineer may require the application of water to the pavement to accelerate the finish rolling of the pavement and to shorten the time required before reopening to traffic.

Before closing an intersection, advance warning signs shall be placed and signs shall also be placed marking the detour or alternate route.

During paving operations, temporary pavement markings shall be maintained throughout the project. Temporary pavement markings shall be installed on the Roadway prior to opening to traffic. Temporary pavement markings shall be in accordance with Section 8-23.

All costs in connection with performing the Work in accordance with these requirements, except the cost of temporary pavement markings, shall be included in the unit Contract prices for the various Bid items involved in the Contract.

5-04.3(3) Equipment

5-04.3(3)A Mixing Plant

Plants used for the preparation of HMA shall conform to the following requirements:

- 1. Equipment for Preparation of Asphalt Binder** – Tanks for the storage of asphalt binder shall be equipped to heat and hold the material at the required temperatures. The heating shall be accomplished by steam coils, electricity, or other approved means so that no flame shall be in contact with the storage tank. The circulating system for the asphalt binder shall be designed to ensure proper and continuous circulation during the operating period. A valve for the purpose of sampling the asphalt binder shall be placed in either the storage tank or in the supply line to the mixer.
- 2. Thermometric Equipment** – An armored thermometer, capable of detecting temperature ranges expected in the HMA mix, shall be fixed in the asphalt binder feed line at a location near the charging valve at the mixer unit. The thermometer location shall be convenient and safe for access by Inspectors. The plant shall also be equipped with an approved dial-scale thermometer, a mercury actuated thermometer, an electric pyrometer, or another approved thermometric instrument

placed at the discharge chute of the drier to automatically register or indicate the temperature of the heated aggregates. This device shall be in full view of the plant operator.

3. **Heating of Asphalt Binder** – The temperature of the asphalt binder shall not exceed the maximum recommended by the asphalt binder manufacturer nor shall it be below the minimum temperature required to maintain the asphalt binder in a homogeneous state. The asphalt binder shall be heated in a manner that will avoid local variations in heating. The heating method shall provide a continuous supply of asphalt binder to the mixer at a uniform average temperature with no individual variations exceeding 25°F. Also, when a WMA additive is included in the asphalt binder, the temperature of the asphalt binder shall not exceed the maximum recommended by the manufacturer of the WMA additive.
4. **Sampling and Testing of Mineral Materials** – The HMA plant shall be equipped with a mechanical sampler for the sampling of the mineral materials. The mechanical sampler shall meet the requirements of Section 1-05.6 for the crushing and screening operation. The Contractor shall provide for the setup and operation of the field testing facilities of the Contracting Agency as provided for in Section 3-01.2(2).
5. **Sampling HMA** – The HMA plant shall provide for sampling HMA by one of the following methods:
 - a. A mechanical sampling device attached to the HMA plant.
 - b. Platforms or devices to enable sampling from the hauling vehicle without entering the hauling vehicle.

5-04.3(3)B Hauling Equipment

Trucks used for hauling HMA shall have tight, clean, smooth metal beds and shall have a cover of canvas or other suitable material of sufficient size to protect the mixture from adverse weather. Whenever the weather conditions during the work shift include, or are forecast to include, precipitation or an air temperature less than 45°F or when time from loading to unloading exceeds 30 minutes, the cover shall be securely attached to protect the HMA.

The contractor shall provide an environmentally benign means to prevent the HMA mixture from adhering to the hauling equipment. Excess release agent shall be drained prior to filling hauling equipment with HMA. Petroleum derivatives or other coating material that contaminate or alter the characteristics of the HMA shall not be used. For live bed trucks, the conveyor shall be in operation during the process of applying the release agent.

5-04.3(3)C Pavers

HMA pavers shall be self-contained, power-propelled units, provided with an internally heated vibratory screed and shall be capable of spreading and finishing courses of HMA plant mix material in lane widths required by the paving section shown in the Plans.

The HMA paver shall be in good condition and shall have the most current equipment available from the manufacturer for the prevention of segregation of the HMA mixture installed, in good condition, and in working order. The equipment certification shall list the make, model, and year of the paver and any equipment that has been retrofitted.

CITY OF FEDERAL WAY

**21ST AVE S & S 320TH STREET
SIGNALIZATION AND PEDESTRIAN
IMPROVEMENTS PROJECT
PROJECT #36225**

SP-67

CFW SPECIAL PROVISIONS VER. 2023.06

***** PLAN CENTER COPY *** Official bid documents, plan holder's list, and addenda (if applicable) are available on BXWA.com**

The screed shall be operated in accordance with the manufacturer's recommendations and shall effectively produce a finished surface of the required evenness and texture without tearing, shoving, segregating, or gouging the mixture. A copy of the manufacturer's recommendations shall be provided upon request by the Contracting Agency. Extensions will be allowed provided they produce the same results, including ride, density, and surface texture as obtained by the primary screed. Extensions without augers and an internally heated vibratory screed shall not be used in the Traveled Way.

When specified in the Contract, reference lines for vertical control will be required. Lines shall be placed on both outer edges of the Traveled Way of each Roadway. Horizontal control utilizing the reference line will be permitted. The grade and slope for intermediate lanes shall be controlled automatically from reference lines or by means of a mat referencing device and a slope control device. When the finish of the grade prepared for paving is superior to the established tolerances and when, in the opinion of the Engineer, further improvement to the line, grade, cross-section, and smoothness can best be achieved without the use of the reference line, a mat referencing device may be substituted for the reference line. Substitution of the device will be subject to the continued approval of the Engineer. A joint matcher may be used subject to the approval of the Engineer. The reference line may be removed after the completion of the first course of HMA when approved by the Engineer. Whenever the Engineer determines that any of these methods are failing to provide the necessary vertical control, the reference lines will be reinstalled by the Contractor.

The Contractor shall furnish and install all pins, brackets, tensioning devices, wire, and accessories necessary for satisfactory operation of the automatic control equipment.

If the paving machine in use is not providing the required finish, the Engineer may suspend Work as allowed by Section 1-08.6. Any cleaning or solvent type liquids spilled on the pavement shall be thoroughly removed before paving proceeds.

5-04.3(3)D Material Transfer Device or Material Transfer Vehicle

A Material Transfer Device/Vehicle (MTD/V) shall only be used with the Engineer's approval, unless other-wise required by the contract.

Where an MTD/V is required by the contract, the Engineer may approve paving without an MTD/V, at the request of the Contractor. The Engineer will determine if an equitable adjustment in cost or time is due.

When used, the MTD/V shall mix the HMA after delivery by the hauling equipment and prior to laydown by the paving machine. Mixing of the HMA shall be sufficient to obtain a uniform temperature throughout the mixture. If a windrow elevator is used, the length of the windrow may be limited in urban areas or through intersections, at the discretion of the Engineer.

To be approved for use, an MTV:

1. Shall be self-propelled vehicle, separate from the hauling vehicle or paver.
2. Shall not be connected to the hauling vehicle or paver.
3. May accept HMA directly from the haul vehicle or pick up HMA from a windrow.

CITY OF FEDERAL WAY

**21ST AVE S & S 320TH STREET
SIGNALIZATION AND PEDESTRIAN
IMPROVEMENTS PROJECT
PROJECT #36225**

SP-68

CFW SPECIAL PROVISIONS VER. 2023.06

4. Shall mix the HMA after delivery by the hauling equipment and prior to placement into the paving machine.
5. Shall mix the HMA sufficiently to obtain a uniform temperature throughout the mixture.

To be approved for use, an MTD:

1. Shall be positively connected to the paver.
2. May accept HMA directly from the haul vehicle or pick up HMA from a windrow.
3. Shall mix the HMA after delivery by the hauling equipment and prior to placement into the paving machine.
4. Shall mix the HMA sufficiently to obtain a uniform temperature throughout the mixture.

5-04.3(3)E Rollers

Rollers shall be of the steel wheel, vibratory, oscillatory, or pneumatic tire type, in good condition and capable of reversing without backlash. Operation of the roller shall be in accordance with the manufacturer's recommendations. When ordered by the Engineer for any roller planned for use on the project, the Contractor shall provide a copy of the manufacturer's recommendation for the use of that roller for compaction of HMA. The number and weight of rollers shall be sufficient to compact the mixture in compliance with the requirements of Section 5-04.3(10). The use of equipment that results in crushing of the aggregate will not be permitted. Rollers producing pickup, washboard, uneven compaction of the surface, displacement of the mixture or other undesirable results shall not be used.

5-04.3(4) Preparation of Existing Paved Surfaces

When the surface of the existing pavement or old base is irregular, the Contractor shall bring it to a uniform grade and cross-section as shown on the Plans or approved by the Engineer.

Preleveling of uneven or broken surfaces over which HMA is to be placed may be accomplished by using an asphalt paver, a motor patrol grader, or by hand raking, as approved by the Engineer.

Compaction of preleveling HMA shall be to the satisfaction of the Engineer and may require the use of small steel wheel rollers, plate compactors, or pneumatic rollers to avoid bridging across preleveled areas by the compaction equipment. Equipment used for the compaction of preleveling HMA shall be approved by the Engineer.

Before construction of HMA on an existing paved surface, the entire surface of the pavement shall be clean. All fatty asphalt patches, grease drippings, and other objectionable matter shall be entirely removed from the existing pavement. All pavements or bituminous surfaces shall be thoroughly cleaned of dust, soil, pavement grindings, and other foreign matter. All holes and small depressions shall be filled with an appropriate class of HMA. The surface of the patched area shall be leveled and compacted thoroughly. Prior to the application of tack coat, or paving, the condition of the surface shall be approved by the Engineer.

CITY OF FEDERAL WAY

**21ST AVE S & S 320TH STREET
SIGNALIZATION AND PEDESTRIAN
IMPROVEMENTS PROJECT
PROJECT #36225**

SP-69

CFW SPECIAL PROVISIONS VER. 2023.06

***** PLAN CENTER COPY *** Official bid documents, plan holder's list, and addenda (if applicable) are available on BXWA.com**

A tack coat of asphalt shall be applied to all paved surfaces on which any course of HMA is to be placed or abutted; except that tack coat may be omitted from clean, newly paved surfaces at the discretion of the Engineer. Tack coat shall be uniformly applied to cover the existing pavement with a thin film of residual asphalt free of streaks and bare spots at a rate between 0.02 and 0.10 gallons per square yard of retained asphalt. The rate of application shall be approved by the Engineer. A heavy application of tack coat shall be applied to all joints. For Roadways open to traffic, the application of tack coat shall be limited to surfaces that will be paved during the same working shift. The spreading equipment shall be equipped with a thermometer to indicate the temperature of the tack coat material.

Equipment shall not operate on tacked surfaces until the tack has broken and cured. If the Contractor's operation damages the tack coat it shall be repaired prior to placement of the HMA.

The tack coat shall be CSS-1, or CSS-1h emulsified asphalt. The CSS-1 and CSS-1h emulsified asphalt may be diluted once with water at a rate not to exceed one part water to one part emulsified asphalt. The tack coat shall have sufficient temperature such that it may be applied uniformly at the specified rate of application and shall not exceed the maximum temperature recommended by the emulsified asphalt manufacturer.

5-04.3(4)A Crack Sealing

5-04.3(4)A1 General

When the Proposal includes a pay item for crack sealing, seal all cracks ¼ inch in width and greater.

Cleaning: Ensure that cracks are thoroughly clean, dry and free of all loose and foreign material when filling with crack sealant material. Use a hot compressed air lance to dry and warm the pavement surfaces within the crack immediately prior to filling a crack with the sealant material. Do not overheat pavement. Do not use direct flame dryers. Routing cracks is not required.

Sand Slurry: For cracks that are to be filled with sand slurry, thoroughly mix the components and pour the mixture into the cracks until full. Add additional CSS-1 cationic emulsified asphalt to the sand slurry as needed for workability to ensure the mixture will completely fill the cracks. Strike off the sand slurry flush with the existing pavement surface and allow the mixture to cure. Top off cracks that were not completely filled with additional sand slurry. Do not place the HMA overlay until the slurry has fully cured.

The sand slurry shall consist of approximately 20 percent CSS-1 emulsified asphalt, approximately 2 percent portland cement, water (if required), and the remainder clean Class 1 or 2 fine aggregate per section 9-03.1(2). The components shall be thoroughly mixed and then poured into the cracks and joints until full. The following day, any cracks or joints that are not completely filled shall be topped off with additional sand slurry. After the sand slurry is placed, the filler shall be struck off flush with the existing pavement surface and allowed to cure. The HMA overlay shall not be placed until the slurry has fully cured. The requirements of Section 1-06 will not apply to the portland cement and sand used in the sand slurry.

CITY OF FEDERAL WAY

**21ST AVE S & S 320TH STREET
SIGNALIZATION AND PEDESTRIAN
IMPROVEMENTS PROJECT
PROJECT #36225**

SP-70

CFW SPECIAL PROVISIONS VER. 2023.06

*** PLAN CENTER COPY *** Official bid documents, plan holder's list, and addenda (if applicable) are available on BXWA.com

In areas where HMA will be placed, use sand slurry to fill the cracks.

In areas where HMA will not be placed, fill the cracks as follows:

1. Cracks ¼ inch to 1 inch in width - fill with hot poured sealant.
2. Cracks greater than 1 inch in width – fill with sand slurry.

Hot Poured Sealant: For cracks that are to be filled with hot poured sealant, apply the material in accordance with these requirements and the manufacturer's recommendations. Furnish a Type 1 Working Drawing of the manufacturer's product information and recommendations to the Engineer prior to the start of work, including the manufacturer's recommended heating time and temperatures, allowable storage time and temperatures after initial heating, allowable reheating criteria, and application temperature range. Confine hot poured sealant material within the crack. Clean any overflow of sealant from the pavement surface. If, in the opinion of the Engineer, the Contractor's method of sealing the cracks with hot poured sealant results in an excessive amount of material on the pavement surface, stop and correct the operation to eliminate the excess material.

5-04.3(4)A2 Crack Sealing Areas Prior to Paving

In areas where HMA will be placed, use sand slurry to fill the cracks.

5-04.3(4)A3 Crack Sealing Areas Not to be Paved

In areas where HMA will not be placed, fill the cracks as follows:

- A. Cracks ¼ inch to 1 inch in width - fill with hot poured sealant.
- B. Cracks greater than 1 inch in width – fill with sand slurry.

5-04.3(4)B Vacant

5-04.3(4)C Pavement Repair

The Contractor shall excavate pavement repair areas and shall backfill these with HMA in accordance with the details shown in the Plans and as marked in the field. The Contractor shall conduct the excavation operations in a manner that will protect the pavement that is to remain. Pavement not designated to be removed that is damaged as a result of the Contractor's operations shall be repaired by the Contractor to the satisfaction of the Engineer at no cost to the Contracting Agency. The Contractor shall excavate only within one lane at a time unless approved otherwise by the Engineer. The Contractor shall not excavate more area than can be completely finished during the same shift, unless approved by the Engineer.

Unless otherwise shown in the Plans or determined by the Engineer, excavate to a depth of 1.0 feet. The Engineer will make the final determination of the excavation depth required. The minimum width of any pavement repair area shall be 40 inches unless shown otherwise in the Plans. Before any excavation, the existing pavement shall be sawcut or shall be removed by a pavement grinder. Excavated materials will become the property of the Contractor and shall be disposed of in a Contractor-provided site off the Right of Way or used in accordance with Sections 2-02.3(3) or 9-03.21.

CITY OF FEDERAL WAY

**21ST AVE S & S 320TH STREET
SIGNALIZATION AND PEDESTRIAN
IMPROVEMENTS PROJECT
PROJECT #36225**

SP-71

CFW SPECIAL PROVISIONS VER. 2023.06

Asphalt for tack coat shall be required as specified in Section 5-04.3(4). A heavy application of tack coat shall be applied to all surfaces of existing pavement in the pavement repair area.

Placement of the HMA backfill shall be accomplished in lifts not to exceed 0.35-foot compacted depth. Lifts that exceed 0.35-foot of compacted depth may be accomplished with the approval of the Engineer. Each lift shall be thoroughly compacted by a mechanical tamper or a roller.

5-04.3(5) Producing/Stockpiling Aggregates and RAP

Aggregates and RAP shall be stockpiled according to the requirements of Section 3-02. Sufficient storage space shall be provided for each size of aggregate and RAP. Materials shall be removed from stockpile(s) in a manner to ensure minimal segregation when being moved to the HMA plant for processing into the final mixture. Different aggregate sizes shall be kept separated until they have been delivered to the HMA plant.

5-04.3(5)A Vacant

5-04.3(6) Mixing

After the required amount of mineral materials, asphalt binder, recycling agent and anti-stripping additives have been introduced into the mixer the HMA shall be mixed until complete and uniform coating of the particles and thorough distribution of the asphalt binder throughout the mineral materials is ensured.

When discharged, the temperature of the HMA shall not exceed the optimum mixing temperature by more than 25°F as shown on the reference mix design report or as approved by the Engineer. Also, when a WMA additive is included in the manufacture of HMA, the discharge temperature of the HMA shall not exceed the maximum recommended by the manufacturer of the WMA additive. A maximum water content of 2 percent in the mix, at discharge, will be allowed providing the water causes no problems with handling, stripping, or flushing. If the water in the HMA causes any of these problems, the moisture content shall be reduced as directed by the Engineer.

Storing or holding of the HMA in approved storage facilities will be permitted with approval of the Engineer, but in no event shall the HMA be held for more than 24 hours. HMA held for more than 24 hours after mixing shall be rejected. Rejected HMA shall be disposed of by the Contractor at no expense to the Contracting Agency. The storage facility shall have an accessible device located at the top of the cone or about the third point. The device shall indicate the amount of material in storage. No HMA shall be accepted from the storage facility when the HMA in storage is below the top of the cone of the storage facility, except as the storage facility is being emptied at the end of the working shift.

Recycled asphalt pavement (RAP) utilized in the production of HMA shall be sized prior to entering the mixer so that a uniform and thoroughly mixed HMA is produced. If there is evidence of the recycled asphalt pavement not breaking down during the heating and mixing of the HMA, the Contractor shall immediately suspend the use of the RAP until changes have been approved by the Engineer. After the required amount of mineral materials, RAP, new asphalt binder and asphalt rejuvenator have been introduced into the mixer the HMA shall be mixed until complete and uniform coating of the particles and

CITY OF FEDERAL WAY

**21ST AVE S & S 320TH STREET
SIGNALIZATION AND PEDESTRIAN
IMPROVEMENTS PROJECT
PROJECT #36225**

SP-72

CFW SPECIAL PROVISIONS VER. 2023.06

*** PLAN CENTER COPY *** Official bid documents, plan holder's list, and addenda (if applicable) are available on BXWA.com

thorough distribution of the asphalt binder throughout the mineral materials, and RAP is ensured.

5-04.3(7) Spreading and Finishing

The mixture shall be laid upon an approved surface, spread, and struck off to the grade and elevation established. HMA pavers complying with Section 5-04.3(3) shall be used to distribute the mixture. Unless otherwise directed by the Engineer, the nominal compacted depth of any layer of any course shall not exceed the following:

HMA Class 1"	0.35 feet
HMA Class ¾" and HMA Class ½"	
wearing course	0.30 feet
other courses	0.35 feet
HMA Class ⅜"	0.15 feet

On areas where irregularities or unavoidable obstacles make the use of mechanical spreading and finishing equipment impractical, the paving may be done with other equipment or by hand.

When more than one JMF is being utilized to produce HMA, the material produced for each JMF shall be placed by separate spreading and compacting equipment. The intermingling of HMA produced from more than one JMF is prohibited. Each strip of HMA placed during a work shift shall conform to a single JMF established for the class of HMA specified unless there is a need to make an adjustment in the JMF.

5-04.3(8) Aggregate Acceptance Prior to Incorporation in HMA

For HMA accepted by nonstatistical evaluation the aggregate properties of sand equivalent, uncompacted void content and fracture will be evaluated in accordance with Section 3-04. Sampling and testing of aggregates for HMA accepted by commercial evaluation will be at the option of the Engineer.

5-04.3(9) HMA Mixture Acceptance

Acceptance of HMA shall be as provided under nonstatistical, or commercial evaluation.

Nonstatistical evaluation will be used for the acceptance of HMA unless Commercial Evaluation is specified.

Commercial evaluation will be used for Commercial HMA and for other classes of HMA in the following applications: sidewalks, road approaches, ditches, slopes, paths, trails, gores, prelevel, temporary pavement, and pavement repair. Other nonstructural applications of HMA accepted by commercial evaluation shall be as approved by the Engineer. Sampling and testing of HMA accepted by commercial evaluation will be at the option of the Engineer.

The mix design will be the initial JMF for the class of HMA. The Contractor may request a change in the JMF. Any adjustments to the JMF will require the approval of the Engineer and may be made in accordance with this section.

HMA Tolerances and Adjustments

CITY OF FEDERAL WAY

**21ST AVE S & S 320TH STREET
SIGNALIZATION AND PEDESTRIAN
IMPROVEMENTS PROJECT
PROJECT #36225**

SP-73

- Job Mix Formula Tolerances** – The constituents of the mixture at the time of acceptance shall be within tolerance. The tolerance limits will be established as follows:

For Asphalt Binder and Air Voids (Va), the acceptance limits are determined by adding the tolerances below to the approved JMF values. These values will also be the Upper Specification Limit (USL) and Lower Specification Limit (LSL) required in Section 1-06.2(2)D2

Property	Non-Statistical Evaluation	Commercial Evaluation
Asphalt Binder	+/- 0.5%	+/- 0.7%
Air Voids, Va	2.5% min. and 5.5% max	N/A

For Aggregates in the mixture:

- First, determine preliminary upper and lower acceptance limits by applying the following tolerances to the approved JMF.

Aggregate Percent Passing	Non-Statistical Evaluation	Commercial Evaluation
1", ¾", ½", and 3/8" sieves	+/- 6%	+/- 8%
No. 4 sieve	+/-6%	+/- 8%
No. 8 Sieve	+/- 6%	+/-8%
No. 200 sieve	+/- 2.0%	+/- 3.0%

- Second, adjust the preliminary upper and lower acceptance limits determined from step (a) the minimum amount necessary so that none of the aggregate properties are outside the control points in Section 9-03.8(6). The resulting values will be the upper and lower acceptance limits for aggregates, as well as the USL and LSL required in Section 1-06.2(2)D2.
- Job Mix Formula Adjustments** – An adjustment to the aggregate gradation or asphalt binder content of the JMF requires approval of the Engineer. Adjustments to the JMF will only be considered if the change produces material of equal or better quality and may require the development of a new mix design if the adjustment exceeds the amounts listed below.
 - Aggregates** –2 percent for the aggregate passing the 1½", 1", ¾", ½", ⅜", and the No. 4 sieves, 1 percent for aggregate passing the No. 8 sieve, and 0.5 percent for the aggregate passing the No. 200 sieve. The adjusted JMF shall be within the range of the control points in Section 9-03.8(6).
 - Asphalt Binder Content** – The Engineer may order or approve changes to asphalt binder content. The maximum adjustment from the approved mix design for the asphalt binder content shall be 0.3 percent

5-04.3(9)A Vacant

5-04.3(9)B Vacant

5-04.3(9)C Mixture Acceptance – Nonstatistical Evaluation

HMA mixture which is accepted by Nonstatistical Evaluation will be evaluated by the Contracting Agency by dividing the HMA tonnage into lots.

5-04.3(9)C1 Mixture Nonstatistical Evaluation – Lots and Sublots

A lot is represented by randomly selected samples of the same mix design that will be tested for acceptance. A lot is defined as the total quantity of material or work produced for each Job Mix Formula placed. Only one lot per JMF is expected. A subplot shall be equal to one day's production or 800 tons, whichever is less except that the final subplot will be a minimum of 400 tons and may be increased to 1200 tons.

CITY OF FEDERAL WAY

21ST AVE S & S 320TH STREET
 SIGNALIZATION AND PEDESTRIAN
 IMPROVEMENTS PROJECT
 PROJECT #36225

SP-74

All of the test results obtained from the acceptance samples from a given lot shall be evaluated collectively. If the Contractor requests a change to the JMF that is approved, the material produced after the change will be evaluated on the basis of the new JMF for the remaining sublots in the current lot and for acceptance of subsequent lots. For a lot in progress with a CPF less than 0.75, a new lot will begin at the Contractor's request after the Engineer is satisfied that material conforming to the Specifications can be produced.

Sampling and testing for evaluation shall be performed on the frequency of one sample per subplot.

5-04.3(9)C2 Mixture Nonstatistical Evaluation Sampling

Samples for acceptance testing shall be obtained by the Contractor when ordered by the Engineer. The Contractor shall sample the HMA mixture in the presence of the Engineer and in accordance with AASH-TO T 168. A minimum of three samples should be taken for each class of HMA placed on a project. If used in a structural application, at least one of the three samples shall to be tested.

Sampling and testing HMA in a Structural application where quantities are less than 400 tons is at the dis-cretion of the Engineer.

For HMA used in a structural application and with a total project quantity less than 800 tons but more than 400 tons, a minimum of one acceptance test shall be performed. In all cases, a minimum of 3 samples will be obtained at the point of acceptance, a minimum of one of the three samples will be tested for conformance to the JMF:

- If the test results are found to be within specification requirements, additional testing will be at the Engineer's discretion.
- If test results are found not to be within specification requirements, additional testing of the remaining samples to determine a Composite Pay Factor (CPF) shall be performed.

5-04.3(9)C3 Mixture Nonstatistical Evaluation – Acceptance Testing

Testing of HMA for compliance of Va will at the option of the Contracting Agency. If tested, compliance of Va will use WSDOT SOP 731.

Testing for compliance of asphalt binder content will be by WSDOT FOP for AASHTO T 308.

Testing for compliance of gradation will be by FOP for WAQTC T 27/T 11.

5-04.3(9)C4 Mixture Nonstatistical Evaluation – Pay Factors

For each lot of material falling outside the tolerance limits in 5-04.3(9), the Contracting Agency will determine a Composite Pay Factor (CPF) using the following price adjustment factors:

Table of Price Adjustment Factors	
Constituent	Factor “f”

CITY OF FEDERAL WAY

21ST AVE S & S 320TH STREET
 SIGNALIZATION AND PEDESTRIAN
 IMPROVEMENTS PROJECT
 PROJECT #36225

SP-75

All aggregate passing: 1½", 1", ¾", ½", ⅜" and No.4 sieves	2
All aggregate passing No. 8 sieve	15
All aggregate passing No. 200 sieve	20
Asphalt binder	40
Air Voids (Va) (where applicable)	20

Each lot of HMA produced under Nonstatistical Evaluation and having all constituents falling within the tolerance limits of the job mix formula shall be accepted at the unit Contract price with no further evaluation. When one or more constituents fall outside the nonstatistical tolerance limits in the Job Mix Formula shown in Table of Price Adjustment Factors, the lot shall be evaluated in accordance with Section 1-06.2 to determine the appropriate CPF. The nonstatistical tolerance limits will be used in the calculation of the CPF and the maximum CPF shall be 1.00. When less than three sublots exist, backup samples of the existing sublots or samples from the Roadway shall be tested to provide a minimum of three sets of results for evaluation.

5-04.3(9)C5 Vacant

5-04.3(9)C6 Mixture Nonstatistical Evaluation – Price Adjustments

For each lot of HMA mix produced under Nonstatistical Evaluation when the calculated CPF is less than 1.00, a Nonconforming Mix Factor (NCMF) will be determined. The NCMF equals the algebraic difference of CPF minus 1.00 multiplied by 60 percent. The total job mix compliance price adjustment will be calculated as the product of the NCMF, the quantity of HMA in the lot in tons, and the unit Contract price per ton of mix.

If a constituent is not measured in accordance with these Specifications, its individual pay factor will be considered 1.00 in calculating the Composite Pay Factor (CPF).

5-04.3(9)C7 Mixture Nonstatistical Evaluation - Retests

The Contractor may request a subplot be retested. To request a retest, the Contractor shall submit a written request within 7 calendar days after the specific test results have been received. A split of the original acceptance sample will be retested. The split of the sample will not be tested with the same tester that ran the original acceptance test. The sample will be tested for a complete gradation analysis, asphalt binder content, and, at the option of the agency, Va. The results of the retest will be used for the acceptance of the HMA in place of the original subplot sample test results. The cost of testing will be deducted from any monies due or that may come due the Contractor under the Contract at the rate of \$500 per sample.

5-04.3 (9)D Mixture Acceptance – Commercial Evaluation

If sampled and tested, HMA produced under Commercial Evaluation and having all constituents falling within the tolerance limits of the job mix formula shall be accepted at the unit Contract price with no further evaluation. When one or more constituents fall outside the commercial tolerance limits in the Job Mix Formula shown in 5-04.3(9), the lot shall be evaluated in accordance with Section 1-06.2 to determine the appropriate CPF. The commercial tolerance limits will be used in the calculation of the CPF and the

CITY OF FEDERAL WAY

**21ST AVE S & S 320TH STREET
SIGNALIZATION AND PEDESTRIAN
IMPROVEMENTS PROJECT
PROJECT #36225**

SP-76

maximum CPF shall be 1.00. When less than three sublots exist, backup samples of the existing sublots or samples from the street shall be tested to provide a minimum of three sets of results for evaluation.

For each lot of HMA mix produced and tested under Commercial Evaluation when the calculated CPF is less than 1.00, a Nonconforming Mix Factor (NCMF) will be determined. The NCMF equals the algebraic difference of CPF minus 1.00 multiplied by 60 percent. The Job Mix Compliance Price Adjustment will be calculated as the product of the NCMF, the quantity of HMA in the lot in tons, and the unit Contract price per ton of mix.

If a constituent is not measured in accordance with these Specifications, its individual pay factor will be considered 1.00 in calculating the Composite Pay Factor (CPF).

5-04.3(10) HMA Compaction Acceptance

HMA mixture accepted by nonstatistical evaluation that is used in traffic lanes, including lanes for intersections, ramps, truck climbing, weaving, and speed change, and having a specified compacted course thickness greater than 0.10-foot, shall be compacted to a specified level of relative density. The specified level of relative density shall be a Composite Pay Factor (CPF) of not less than 0.75 when evaluated in accordance with Section 1-06.2, using a LSL of 92.0 (minimum of 92 percent of the maximum density). The maximum density shall be determined by WSDOT FOP for AASHTO T 729. The specified level of density attained will be determined by the evaluation of the density of the pavement. The density of the pavement shall be determined in accordance with WSDOT FOP for WAQTC TM 8, except that gauge correlation will be at the discretion of the Engineer, when using the nuclear density gauge and WSDOT SOP 736 when using cores to determine density.

Tests for the determination of the pavement density will be taken in accordance with the required procedures for measurement by a nuclear density gauge or roadway cores after completion of the finish rolling.

If the Contracting Agency uses a nuclear density gauge to determine density the test procedures FOP for WAQTC TM 8 and WSDOT SOP T 729 will be used on the day the mix is placed and prior to opening to traffic.

Roadway cores for density may be obtained by either the Contracting Agency or the Contractor in accordance with WSDOT SOP 734. The core diameter shall be 4-inches minimum, unless otherwise approved by the Engineer. Roadway cores will be tested by the Contracting Agency in accordance with WSDOT FOP for AASHTO T 166.

If the Contract includes the Bid item "Roadway Core" the cores shall be obtained by the Contractor in the presence of the Engineer on the same day the mix is placed and at locations designated by the Engineer. If the Contract does not include the Bid item "Roadway Core" the Contracting Agency will obtain the cores.

For a lot in progress with a CPF less than 0.75, a new lot will begin at the Contractor's request after the Engineer is satisfied that material conforming to the Specifications can be produced.

HMA mixture accepted by commercial evaluation and HMA constructed under conditions other than those listed above shall be compacted on the basis of a test point evaluation of the compaction train. The test point evaluation shall be performed in accordance with instructions from the Engineer. The number of passes with an approved compaction train, required to attain the maximum test point density, shall be used on all subsequent paving.

HMA for preleveling shall be thoroughly compacted. HMA that is used for preleveling wheel rutting shall be compacted with a pneumatic tire roller unless otherwise approved by the Engineer.

Test Results

For a subplot that has been tested with a nuclear density gauge that did not meet the minimum of 92 percent of the reference maximum density in a compaction lot with a CPF below 1.00 and thus subject to a price reduction or rejection, the Contractor may request that a core be used for determination of the relative density of the subplot. The relative density of the core will replace the relative density determined by the nuclear density gauge for the subplot and will be used for calculation of the CPF and acceptance of HMA compaction lot.

When cores are taken by the Contracting Agency at the request of the Contractor, they shall be requested by noon of the next workday after the test results for the subplot have been provided or made available to the Contractor. Core locations shall be outside of wheel paths and as determined by the Engineer. Traffic control shall be provided by the Contractor as requested by the Engineer. Failure by the Contractor to provide the requested traffic control will result in forfeiture of the request for cores. When the CPF for the lot based on the results of the HMA cores is less than 1.00, the cost for the coring will be deducted from any monies due or that may become due the Contractor under the Contract at the rate of \$200 per core and the Contractor shall pay for the cost of the traffic control.

5-04.3(10)A HMA Compaction – General Compaction Requirements

Compaction shall take place when the mixture is in the proper condition so that no undue displacement, cracking, or shoving occurs. Areas inaccessible to large compaction equipment shall be compacted by other mechanical means. Any HMA that becomes loose, broken, contaminated, shows an excess or deficiency of asphalt, or is in any way defective, shall be removed and replaced with new hot mix that shall be immediately compacted to conform to the surrounding area.

The type of rollers to be used and their relative position in the compaction sequence shall generally be the Contractor's option, provided the specified densities are attained. Unless the Engineer has approved otherwise, rollers shall only be operated in the static mode when the internal temperature of the mix is less than 175°F. Regardless of mix temperature, a roller shall not be operated in a mode that results in checking or cracking of the mat. Rollers shall only be operated in static mode on bridge decks.

5-04.3(10)B HMA Compaction – Cyclic Density

Low cyclic density areas are defined as spots or streaks in the pavement that are less than 90 percent of the theoretical maximum density. At the Engineer's discretion, the Engineer may evaluate the HMA pavement for low cyclic density, and when doing so will

CITY OF FEDERAL WAY

**21ST AVE S & S 320TH STREET
SIGNALIZATION AND PEDESTRIAN
IMPROVEMENTS PROJECT
PROJECT #36225**

SP-78

CFW SPECIAL PROVISIONS VER. 2023.06

***** PLAN CENTER COPY *** Official bid documents, plan holder's list, and addenda (if applicable) are available on BXWA.com**

follow WSDOT SOP 733. A \$500 Cyclic Density Price Adjustment will be assessed for any 500-foot section with two or more density readings below 90 percent of the theoretical maximum density.

5-04.3(10)C Vacant

5-04.3(10)D HMA Nonstatistical Compaction

5-04.3(10)D1 HMA Nonstatistical Compaction – Lots and Sublots

HMA compaction which is accepted by nonstatistical evaluation will be based on acceptance testing performed by the Contracting Agency dividing the project into compaction lots.

A lot is represented by randomly selected samples of the same mix design that will be tested for acceptance. A lot is defined as the total quantity of material or work produced for each Job Mix Formula placed. Only one lot per JMF is expected. A subplot shall be equal to one day's production or 400 tons, whichever is less except that the final subplot will be a minimum of 200 tons and may be increased to 800 tons. Testing for compaction will be at the rate of 5 tests per subplot per WSDOT T 738.

The subplot locations within each density lot will be determined by the Engineer. For a lot in progress with a CPF less than 0.75, a new lot will begin at the Contractor's request after the Engineer is satisfied that material conforming to the Specifications can be produced.

HMA mixture accepted by commercial evaluation and HMA constructed under conditions other than those listed above shall be compacted on the basis of a test point evaluation of the compaction train. The test point evaluation shall be performed in accordance with instructions from the Engineer. The number of passes with an approved compaction train, required to attain the maximum test point density, shall be used on all subsequent paving.

HMA for preleveling shall be thoroughly compacted. HMA that is used to prelevel wheel ruts shall be compacted with a pneumatic tire roller unless otherwise approved by the Engineer.

5-04.3(10)D2 HMA Compaction Nonstatistical Evaluation – Acceptance Testing

The location of the HMA compaction acceptance tests will be randomly selected by the Engineer from within each subplot, with one test per subplot.

5-04.3(10)D3 HMA Nonstatistical Compaction – Price Adjustments

For each compaction lot with one or two sublots, having all sublots attain a relative density that is 92 percent of the reference maximum density the HMA shall be accepted at the unit Contract price with no further evaluation. When a subplot does not attain a relative density that is 92 percent of the reference maximum density, the lot shall be evaluated in accordance with Section 1-06.2 to determine the appropriate CPF. The maximum CPF shall be 1.00, however, lots with a calculated CPF in excess of 1.00 will be used to offset lots with CPF values below 1.00 but greater than 0.90. Lots with CPF lower than 0.90 will be evaluated for compliance per 5-04.3(11). Additional testing by either a nuclear moisture-density gauge or cores will be completed as required to provide a minimum of three tests for evaluation.

CITY OF FEDERAL WAY

**21ST AVE S & S 320TH STREET
SIGNALIZATION AND PEDESTRIAN
IMPROVEMENTS PROJECT
PROJECT #36225**

SP-79

CFW SPECIAL PROVISIONS VER. 2023.06

*** PLAN CENTER COPY *** Official bid documents, plan holder's list, and addenda (if applicable) are available on BXWA.com

For compaction below the required 92% a Non-Conforming Compaction Factor (NCCF) will be determined. The NCCF equals the algebraic difference of CPF minus 1.00 multiplied by 40 percent. The Compaction Price Adjustment will be calculated as the product of CPF, the quantity of HMA in the compaction control lot in tons, and the unit Contract price per ton of mix.

5-04.3(11) Reject Work

5-04.3(11)A Reject Work General

Work that is defective or does not conform to Contract requirements shall be rejected. The Contractor may propose, in writing, alternatives to removal and replacement of rejected material. Acceptability of such alternative proposals will be determined at the sole discretion of the Engineer. HMA that has been rejected is subject to the requirements in Section 1-06.2(2) and this specification, and the Contractor shall submit a corrective action proposal to the Engineer for approval.

5-04.3(11)B Rejection by Contractor

The Contractor may, prior to sampling, elect to remove any defective material and replace it with new material. Any such new material will be sampled, tested, and evaluated for acceptance.

5-04.3(11)C Rejection Without Testing (Mixture or Compaction)

The Engineer may, without sampling, reject any batch, load, or section of Roadway that appears defective. Material rejected before placement shall not be incorporated into the pavement. Any rejected section of Roadway shall be removed.

No payment will be made for the rejected materials or the removal of the materials unless the Contractor requests that the rejected material be tested. If the Contractor elects to have the rejected material tested, a minimum of three representative samples will be obtained and tested. Acceptance of rejected material will be based on conformance with the nonstatistical acceptance Specification. If the CPF for the rejected material is less than 0.75, no payment will be made for the rejected material; in addition, the cost of sampling and testing shall be borne by the Contractor. If the CPF is greater than or equal to 0.75, the cost of sampling and testing will be borne by the Contracting Agency. If the material is rejected before placement and the CPF is greater than or equal to 0.75, compensation for the rejected material will be at a CPF of 0.75. If rejection occurs after placement and the CPF is greater than or equal to 0.75, compensation for the rejected material will be at the calculated CPF with an addition of 25 percent of the unit Contract price added for the cost of removal and disposal.

5-04.3(11)D Rejection - A Partial Sublot

In addition to the random acceptance sampling and testing, the Engineer may also isolate from a normal sublot any material that is suspected of being defective in relative density, gradation or asphalt binder content. Such isolated material will not include an original sample location. A minimum of three random samples of the suspect material will be obtained and tested. The material will then be statistically evaluated as an independent lot in accordance with Section 1-06.2(2).

CITY OF FEDERAL WAY

21ST AVE S & S 320TH STREET
SIGNALIZATION AND PEDESTRIAN
IMPROVEMENTS PROJECT
PROJECT #36225

SP-80

CFW SPECIAL PROVISIONS VER. 2023.06

*** PLAN CENTER COPY *** Official bid documents, plan holder's list, and addenda (if applicable) are available on BXWA.com

5-04.3(11)E Rejection - An Entire Sublot

An entire sublot that is suspected of being defective may be rejected. When a sublot is rejected a minimum of two additional random samples from this sublot will be obtained. These additional samples and the original sublot will be evaluated as an independent lot in accordance with Section 1-06.2(2).

5-04.3(11)F Rejection - A Lot in Progress

The Contractor shall shut down operations and shall not resume HMA placement until such time as the Engineer is satisfied that material conforming to the Specifications can be produced:

1. When the Composite Pay Factor (CPF) of a lot in progress drops below 1.00 and the Contractor is taking no corrective action, or
2. When the Pay Factor (PF) for any constituent of a lot in progress drops below 0.95 and the Contractor is taking no corrective action, or
3. When either the PFI for any constituent or the CPF of a lot in progress is less than 0.75.

5-04.3(11)G Rejection - An Entire Lot (Mixture or Compaction)

An entire lot with a CPF of less than 0.75 will be rejected.

5-04.3(12) Joints

5-04.3(12)A HMA Joints

5-04.3(12)A1 Transverse Joints

The Contractor shall conduct operations such that the placing of the top or wearing course is a continuous operation or as close to continuous as possible. Unscheduled transverse joints will be allowed and the roller may pass over the unprotected end of the freshly laid mixture only when the placement of the course must be discontinued for such a length of time that the mixture will cool below compaction temperature. When the Work is resumed, the previously compacted mixture shall be cut back to produce a slightly beveled edge for the full thickness of the course.

A temporary wedge of HMA constructed on a 20H:1V shall be constructed where a transverse joint as a result of paving or planing is open to traffic. The HMA in the temporary wedge shall be separated from the permanent HMA by strips of heavy wrapping paper or other methods approved by the Engineer. The wrapping paper shall be removed and the joint trimmed to a slightly beveled edge for the full thickness of the course prior to resumption of paving.

The material that is cut away shall be wasted and new mix shall be laid against the cut. Rollers or tamping irons shall be used to seal the joint.

5-04.3(12)A2 Longitudinal Joints

The longitudinal joint in any one course shall be offset from the course immediately below by not more than 6 inches nor less than 2 inches. All longitudinal joints constructed in the wearing course shall be located at a lane line or an edge line of the Traveled Way. A notched wedge joint shall be constructed along all longitudinal joints in the wearing surface

CITY OF FEDERAL WAY

21ST AVE S & S 320TH STREET
SIGNALIZATION AND PEDESTRIAN
IMPROVEMENTS PROJECT
PROJECT #36225

SP-81

CFW SPECIAL PROVISIONS VER. 2023.06

*** PLAN CENTER COPY *** Official bid documents, plan holder's list, and addenda (if applicable) are available on BXWA.com

of new HMA unless otherwise approved by the Engineer. The notched wedge joint shall have a vertical edge of not less than the maximum aggregate size or more than $\frac{1}{2}$ of the compacted lift thickness and then taper down on a slope not steeper than 4H:1V. The sloped portion of the HMA notched wedge joint shall be uniformly compacted.

5-04.3(12)B Bridge Paving Joint Seals

5-04.3(12)B1 HMA Sawcut and Seal

Prior to placing HMA on the bridge deck, establish sawcut alignment points at both ends of the bridge paving joint seals to be placed at the bridge ends, and at interior joints within the bridge deck when and where shown in the Plans. Establish the sawcut alignment points in a manner that they remain functional for use in aligning the sawcut after placing the overlay.

Submit a Type 1 Working Drawing consisting of the sealant manufacturer's application procedure.

Construct the bridge paving joint seal as specified in the Plans and in accordance with the detail shown in the Standard Plans. Construct the sawcut in accordance with the detail shown in the Standard Plan. Construct the sawcut in accordance with Section 5-05.3(8)B and the manufacturer's application procedure.

5-04.3(12)B2 Paved Panel Joint Seal

Construct the paved panel joint seal in accordance with the requirements specified in section 5-04.3(12)B1 and the following requirement:

1. Clean and seal the existing joint between concrete panels in accordance with Section 5-01.3(8) and the details shown in the Standard Plans.

5-04.3(13) Surface Smoothness

The completed surface of all courses shall be of uniform texture, smooth, uniform as to crown and grade, and free from defects of all kinds. The completed surface of the wearing course shall not vary more than $\frac{1}{8}$ inch from the lower edge of a 10-foot straightedge placed on the surface parallel to the centerline. The transverse slope of the completed surface of the wearing course shall vary not more than $\frac{1}{4}$ inch in 10 feet from the rate of transverse slope shown in the Plans.

When deviations in excess of the above tolerances are found that result from a high place in the HMA, the pavement surface shall be corrected by one of the following methods:

1. Removal of material from high places by grinding with an approved grinding machine, or
2. Removal and replacement of the wearing course of HMA, or
3. By other method approved by the Engineer.

Correction of defects shall be carried out until there are no deviations anywhere greater than the allowable tolerances.

Deviations in excess of the above tolerances that result from a low place in the HMA and deviations resulting from a high place where corrective action, in the opinion of the Engineer, will not produce satisfactory results will be accepted with a price adjustment. The Engineer shall deduct from monies due or that may become due to the Contractor the sum of \$500.00 for each and every section of single traffic lane 100 feet in length in which any excessive deviations described above are found.

When utility appurtenances such as manhole covers and valve boxes are located in the traveled way, the utility appurtenances shall be adjusted to the finished grade prior to paving. This requirement may be waived when requested by the Contractor, at the discretion of the Engineer or when the adjustment details provided in the project plan or specifications call for utility appurtenance adjustments after the completion of paving.

Utility appurtenance adjustment discussions will be included in the Pre-Paving planning (5-04.3(14)B3). Submit a written request to waive this requirement to the Engineer prior to the start of paving.

5-04.3(14) Planing (Milling) Bituminous Pavement

The planing plan must be approved by the Engineer and a pre planing meeting must be held prior to the start of any planing. See Section 5-04.3(14)B2 for information on planing submittals.

Locations of existing surfacing to be planed are as shown in the Drawings.

Where planing an existing pavement is specified in the Contract, the Contractor must remove existing surfacing material and to reshape the surface to remove irregularities. The finished product must be a prepared surface acceptable for receiving an HMA overlay.

Use the cold milling method for planing unless otherwise specified in the Contract. Do not use the planer on the final wearing course of new HMA.

Conduct planing operations in a manner that does not tear, break, burn, or otherwise damage the surface which is to remain. The finished planed surface must be slightly grooved or roughened and must be free from gouges, deep grooves, ridges, or other imperfections. The Contractor must repair any damage to the surface by the Contractor's planing equipment, using an Engineer approved method.

Repair or replace any metal castings and other surface improvements damaged by planing, as determined by the Engineer.

A tapered wedge cut must be planed longitudinally along curb lines sufficient to provide a minimum of 4 inches of curb reveal after placement and compaction of the final wearing course. The dimensions of the wedge must be as shown on the Drawings or as specified by the Engineer.

A tapered wedge cut must also be made at transitions to adjoining pavement surfaces (meet lines) where butt joints are shown on the Drawings. Cut butt joints in a straight line with vertical faces 2 inches or more in height, producing a smooth transition to the existing adjoining pavement.

CITY OF FEDERAL WAY

**21ST AVE S & S 320TH STREET
SIGNALIZATION AND PEDESTRIAN
IMPROVEMENTS PROJECT
PROJECT #36225**

SP-83

CFW SPECIAL PROVISIONS VER. 2023.06

***** PLAN CENTER COPY *** Official bid documents, plan holder's list, and addenda (if applicable) are available on BXWA.com**

After planing is complete, planed surfaces must be swept, cleaned, and if required by the Contract, patched and preleveled.

The Engineer may direct additional depth planing. Before performing this additional depth planing, the Contractor must conduct a hidden metal in pavement detection survey as specified in Section 5-04.3(14)A.

5-04.3(14)A Pre-Planing Metal Detection Check

Before starting planing of pavements, and before any additional depth planing required by the Engineer, the Contractor must conduct a physical survey of existing pavement to be planed with equipment that can identify hidden metal objects.

Should such metal be identified, promptly notify the Engineer.

See Section 1-07.16(1) regarding the protection of survey monumentation that may be hidden in pavement.

The Contractor is solely responsible for any damage to equipment resulting from the Contractor's failure to conduct a pre-planing metal detection survey, or from the Contractor's failure to notify the Engineer of any hidden metal that is detected.

5-04.3(14)B Paving and Planing Under Traffic

5-04.3(14)B1 General

In addition the requirements of Section 1-07.23 and the traffic controls required in Section 1-10, and unless the Contract specifies otherwise or the Engineer approves, the Contractor must comply with the following:

1. Intersections:
 - a. Keep intersections open to traffic at all times, except when paving or planing operations through an intersection requires closure. Such closure must be kept to the minimum time required to place and compact the HMA mixture, or plane as appropriate. For paving, schedule such closure to individual lanes or portions thereof that allows the traffic volumes and schedule of traffic volumes required in the approved traffic control plan. Schedule work so that adjacent intersections are not impacted at the same time and comply with the traffic control restrictions required by the Traffic Engineer. Each individual intersection closure or partial closure, must be addressed in the traffic control plan, which must be submitted to and accepted by the Engineer, see Section 1-10.2(2).
 - b. When planing or paving and related construction must occur in an intersection, consider scheduling and sequencing such work into quarters of the intersection, or half or more of an intersection with side street detours. Be prepared to sequence the work to individual lanes or portions thereof.
 - c. Should closure of the intersection in its entirety be necessary, and no trolley service is impacted, keep such closure to the minimum time required to place and compact the HMA mixture, plane, remove asphalt, tack coat, and as needed.

- d. Any work in an intersection requires advance warning in both signage and a number of Working Days advance notice as determined by the Engineer, to alert traffic and emergency services of the intersection closure or partial closure.
 - e. Allow new compacted HMA asphalt to cool to ambient temperature before any traffic is allowed on it. Traffic is not allowed on newly placed asphalt until approval has been obtained from the Engineer.
2. Temporary centerline marking, post-paving temporary marking, temporary stop bars, and maintaining temporary pavement marking must comply with Section 8-23.
 3. Permanent pavement marking must comply with Section 8-22.

5-04.3(14)B2 Submittals – Planing Plan and HMA Paving Plan

The Contractor must submit a separate planing plan and a separate paving plan to the Engineer at least 5 Working Days in advance of each operation's activity start date. These plans must show how the moving operation and traffic control are coordinated, as they will be discussed at the pre-planing briefing and pre-paving briefing. When requested by the Engineer, the Contractor must provide each operation's traffic control plan on 24 x 36 inch or larger size Shop Drawings with a scale showing both the area of operation and sufficient detail of traffic beyond the area of operation where detour traffic may be required. The scale on the Shop Drawings is 1 inch = 20 feet, which may be changed if the Engineer agrees sufficient detail is shown.

The planing operation and the paving operation include, but are not limited to, metal detection, removal of asphalt and temporary asphalt of any kind, tack coat and drying, staging of supply trucks, paving trains, rolling, scheduling, and as may be discussed at the briefing.

When intersections will be partially or totally blocked, provide adequately sized and noticeable signage alerting traffic of closures to come, a minimum 2 Working Days in advance. The traffic control plan must show where peace officers will be stationed when signalization is or may be, countermanded, and show areas where flaggers are proposed.

At a minimum, the planing and the paving plan must include:

1. A copy of the accepted traffic control plan, see Section 1-10.2(2), detailing each day's traffic control as it relates to the specific requirements of that day's planing and paving. Briefly describe the sequencing of traffic control consistent with the proposed planing and paving sequence, and scheduling of placement of temporary pavement markings and channelizing devices after each day's planing, and paving.
2. A copy of each intersection's traffic control plan.
3. Haul routes from Supplier facilities, and locations of temporary parking and staging areas, including return routes. Describe the complete round trip as it relates to the sequencing of paving operations.
4. Names and locations of HMA Supplier facilities to be used.
5. List of all equipment to be used for paving.
6. List of personnel and associated job classification assigned to each piece of paving equipment.

CITY OF FEDERAL WAY

**21ST AVE S & S 320TH STREET
SIGNALIZATION AND PEDESTRIAN
IMPROVEMENTS PROJECT
PROJECT #36225**

SP-85

CFW SPECIAL PROVISIONS VER. 2023.06

***** PLAN CENTER COPY *** Official bid documents, plan holder's list, and addenda (if applicable) are available on BXWA.com**

7. Description (geometric or narrative) of the scheduled sequence of planing and of paving, and intended area of planing and of paving for each day's work, must include the directions of proposed planing and of proposed paving, sequence of adjacent lane paving, sequence of skipped lane paving, intersection planing and paving scheduling and sequencing, and proposed notifications and coordinations to be timely made. The plan must show HMA joints relative to the final pavement marking lane lines.
8. Names, job titles, and contact information for field, office, and plant supervisory personnel.
9. A copy of the approved Mix Designs.
10. Tonnage of HMA to be placed each day.
11. Approximate times and days for starting and ending daily operations.

5-04.3(14)B3 Pre-Paving and Pre-Planing Briefing

At least 2 Working Days before the first paving operation and the first planing operation, or as scheduled by the Engineer for future paving and planing operations to ensure the Contractor has adequately prepared for notifying and coordinating as required in the Contract, the Contractor must be prepared to discuss that day's operations as they relate to other entities and to public safety and convenience, including driveway and business access, garbage truck operations, Metro transit operations and working around energized overhead wires, school and nursing home and hospital and other accesses, other contractors who may be operating in the area, pedestrian and bicycle traffic, and emergency services. The Contractor, and Subcontractors that may be part of that day's operations, must meet with the Engineer and discuss the proposed operation as it relates to the submitted planing plan and paving plan, approved traffic control plan, and public convenience and safety. Such discussion includes, but is not limited to:

1. General for both Paving Plan and for Planing Plan:
 - a. The actual times of starting and ending daily operations.
 - b. In intersections, how to break up the intersection, and address traffic control and signalization for that operation, including use of peace officers.
 - c. The sequencing and scheduling of paving operations and of planing operations, as applicable, as it relates to traffic control, to public convenience and safety, and to other contractors who may operate in the Project Site.
 - d. Notifications required of Contractor activities, and coordinating with other entities and the public as necessary.
 - e. Description of the sequencing of installation and types of temporary pavement markings as it relates to planning and to paving.
 - f. Description of the sequencing of installation of, and the removal of, temporary pavement patch material around exposed castings and as may be needed
 - g. Description of procedures and equipment to identify hidden metal in the pavement, such as survey monumentation, monitoring wells, street car rail, and castings, before planning, see Section 5-04.3(14)B2.
 - h. Description of how flaggers will be coordinated with the planing, paving, and related operations.
 - i. Description of sequencing of traffic controls for the process of rigid pavement base repairs.
 - j. Other items the Engineer deems necessary to address.
2. Paving – additional topics:

CITY OF FEDERAL WAY

**21ST AVE S & S 320TH STREET
SIGNALIZATION AND PEDESTRIAN
IMPROVEMENTS PROJECT
PROJECT #36225**

SP-86

CFW SPECIAL PROVISIONS VER. 2023.06

*** PLAN CENTER COPY *** Official bid documents, plan holder's list, and addenda (if applicable) are available on BXWA.com

- a. When to start applying tack and coordinating with paving.
- b. Types of equipment and numbers of each type equipment to be used. If more pieces of equipment than personnel are proposed, describe the sequencing of the personnel operating the types of equipment. Discuss the continuance of operator personnel for each type equipment as it relates to meeting Specification requirements.
- c. Number of JMFs to be placed, and if more than one JMF how the Contractor will ensure different JMFs are distinguished, how pavers and MTVs are distinguished if more than one JMF is being placed at the time, and how pavers and MTVs are cleaned so that one JMF does not adversely influence the other JMF.
- d. Description of contingency plans for that day's operations such as equipment breakdown, rain out, and Supplier shutdown of operations.
- e. Number of sublots to be placed, sequencing of density testing, and other sampling and testing.

5-04.3(15) Sealing Pavement Surfaces

Apply a fog seal where shown in the plans. Construct the fog seal in accordance with Section 5-02.3. Unless otherwise approved by the Engineer, apply the fog seal prior to opening to traffic.

5-04.3(16) HMA Road Approaches

HMA approaches shall be constructed at the locations shown in the Plans or where staked by the Engineer. The Work shall be performed in accordance with Section 5-04.

5-04.3(17) Temporary Asphalt Pavement

(December 1, 2021 CFW GSP)

Section 5-04.3(17) is a new section:

Temporary asphalt pavement shall be placed by the Contractor immediately upon the request of the Engineer for the maintenance of traffic during construction. These areas include: voids created by the removal of existing improvements (i.e. Traffic islands, curbs), providing paved access to private properties, and ramps for property access during cement concrete driveway approach construction. All temporary paving shall be approved by the Engineer before placement. Any areas of temporary pavement to be removed and replaced shall be approved by the Engineer beforehand. This work shall also include the removal of temporary asphalt concrete pavement in its entirety prior to final paving.

Hot Mix Asphalt Temporary Pavement: Hot mix asphalt will be used for any trench or pavement restoration within the traveled way. Whether temporary or permanent, saw cut and treat edges with CSS-1 asphalt emulsion and apply a minimum 3-inch pavement depth or match existing, whichever is greater. Also, fill voids created by the removal of existing traffic islands and curbing, paving over excavated roadway to temporary access to adjacent properties, and ramps for property access during concrete approach construction.

Cold Mix Asphalt Temporary Pavement: Cold mix asphalt is allowed for temporary paving outside the traveled way. The cold mix shall be approved by the Engineer and placed in a 2-inch minimum thickness. Placement of temporary

CITY OF FEDERAL WAY

21ST AVE S & S 320TH STREET
SIGNALIZATION AND PEDESTRIAN
IMPROVEMENTS PROJECT
PROJECT #36225

SP-87

CFW SPECIAL PROVISIONS VER. 2023.06

*** PLAN CENTER COPY *** Official bid documents, plan holder's list, and addenda (if applicable) are available on BXWA.com

pavement without prior approval of the Engineer shall be considered as a benefit of the Contractor and no cost to the owner. Any areas of temporary pavement to be removed and replaced require prior approval by the Engineer. This work shall include the removal of the temporary pavement prior to paving of final asphalt concrete pavement.

5-04.4 Measurement

HMA Cl. ____ PG ____, HMA for ____ Cl. ____ PG ____, and Commercial HMA will be measured by the ton in accordance with Section 1-09.2, with no deduction being made for the weight of asphalt binder, mineral filler, or any other component of the mixture. If the Contractor elects to remove and replace mix as allowed by Section 5-04.3(11), the material removed will not be measured.

Roadway cores will be measured per each for the number of cores taken.

Preparation of untreated roadway will be measured by the mile once along the centerline of the main line Roadway. No additional measurement will be made for ramps, Auxiliary Lanes, service roads, Frontage Roads, or Shoulders. Measurement will be to the nearest 0.01 mile.

Soil residual herbicide will be measured by the mile for the stated width to the nearest 0.01 mile or by the square yard, whichever is designated in the Proposal.

Pavement repair excavation will be measured by the square yard of surface marked prior to excavation.

Asphalt for prime coat will be measured by the ton in accordance with Section 1-09.2.

Prime coat aggregate will be measured by the cubic yard, truck measure, or by the ton, whichever is designated in the Proposal.

Asphalt for fog seal will be measured by the ton, as provided in Section 5-02.4.

Longitudinal joint seals between the HMA and cement concrete pavement will be measured by the linear foot along the line and slope of the completed joint seal.

Planing bituminous pavement will be measured by the square yard.

Temporary pavement marking will be measured by the linear foot as provided in Section 8-23.4.

Water will be measured by the M gallon as provided in Section 2-07.4.

(April 12, 2018 CFW GSP)

Section 5-04.4 is supplemented with the following:

Hot Mix Asphalt Temporary Pavement shall be measured by the ton of material actually placed, with no deduction being made for the weight of liquid asphalt, blending sand, mineral filler, or any other component of the mixture. Hot Mix Asphalt Temporary Pavement shall be paid under the "Temporary Pavement" bid

CITY OF FEDERAL WAY

**21ST AVE S & S 320TH STREET
SIGNALIZATION AND PEDESTRIAN
IMPROVEMENTS PROJECT
PROJECT #36225**

SP-88

CFW SPECIAL PROVISIONS VER. 2023.06

***** PLAN CENTER COPY *** Official bid documents, plan holder's list, and addenda (if applicable) are available on BXWA.com**

item and shall include placement and compaction of hot mix asphalt, removal and disposal of temporary pavement.

Cold Mix Asphalt Temporary Pavement will not be measured and shall be considered incidental to other bid items.

5-04.5 Payment

Payment will be made for each of the following Bid items that are included in the Proposal:

“HMA Cl. ___ PG ___”, per ton.

“HMA for Approach Cl. ___ PG ___”, per ton.

“HMA for Preleveling Cl. ___ PG ___”, per ton.

“HMA for Pavement Repair Cl. ___ PG ___”, per ton.

“Commercial HMA”, per ton.

The unit Contract price per ton for “HMA Cl. ___ PG ___”, “HMA for Approach Cl. ___ PG ___”, “HMA for Preleveling Cl. ___ PG ___”, “HMA for Pavement Repair Cl. ___ PG ___”, and “Commercial HMA” shall be full compensation for all costs, including anti-stripping additive, incurred to carry out the requirements of Section 5-04 except for those costs included in other items which are included in this Subsection and which are included in the Proposal.

“Preparation of Untreated Roadway”, per mile.

The unit Contract price per mile for “Preparation of Untreated Roadway” shall be full pay for all Work described under 5-04.3(4) , with the exception, however, that all costs involved in patching the Roadway prior to placement of HMA shall be included in the unit Contract price per ton for “HMA Cl. ___ PG ___” which was used for patching. If the Proposal does not include a Bid item for “Preparation of Untreated Roadway”, the Roadway shall be prepared as specified, but the Work shall be included in the Contract prices of the other items of Work.

“Preparation of Existing Paved Surfaces”, per mile.

The unit Contract Price for “Preparation of Existing Paved Surfaces” shall be full pay for all Work described under Section 5-04.3(4) with the exception, however, that all costs involved in patching the Roadway prior to placement of HMA shall be included in the unit Contract price per ton for “HMA Cl. ___ PG ___” which was used for patching. If the Proposal does not include a Bid item for “Preparation of Untreated Roadway”, the Roadway shall be prepared as specified, but the Work shall be included in the Contract prices of the other items of Work.

“Crack Sealing”, by force account.

CITY OF FEDERAL WAY

**21ST AVE S & S 320TH STREET
SIGNALIZATION AND PEDESTRIAN
IMPROVEMENTS PROJECT
PROJECT #36225**

SP-89

CFW SPECIAL PROVISIONS VER. 2023.06

*** PLAN CENTER COPY *** Official bid documents, plan holder's list, and addenda (if applicable) are available on BXWA.com

“Crack Sealing” will be paid for by force account as specified in Section 1-09.6. For the purpose of providing a common Proposal for all Bidders, the Contracting Agency has entered an amount in the Proposal to become a part of the total Bid by the Contractor.

“Pavement Repair Excavation Incl. Haul”, per cubic yard.

The unit Contract price per cubic yard for “Pavement Repair Excavation Incl. Haul” shall be full payment for all costs incurred to perform the Work described in Section 5-04.3(4) with the exception, however, that all costs involved in the placement of HMA shall be included in the unit Contract price per ton for “HMA for Pavement Repair Cl. ___ PG ___”, per ton.

“Asphalt for Prime Coat”, per ton.

The unit Contract price per ton for “Asphalt for Prime Coat” shall be full payment for all costs incurred to obtain, provide and install the material in accordance with Section 5-04.3(4).

“Prime Coat Agg.”, per cubic yard, or per ton.

The unit Contract price per cubic yard or per ton for “Prime Coat Agg.” shall be full pay for furnishing, loading, and hauling aggregate to the place of deposit and spreading the aggregate in the quantities required by the Engineer.

“Asphalt for Fog Seal”, per ton.

Payment for “Asphalt for Fog Seal” is described in Section 5-02.5.

“Longitudinal Joint Seal”, per linear foot.

The unit Contract price per linear foot for “Longitudinal Joint Seal” shall be full payment for all costs incurred to perform the Work described in Section 5-04.3(12).

“Planing Bituminous Pavement”, per square yard.

The unit Contract price per square yard for “Planing Bituminous Pavement” shall be full payment for all costs incurred to perform the Work described in Section 5-04.3(14).

“Temporary Pavement Marking”, per linear foot.

Payment for “Temporary Pavement Marking” is described in Section 8-23.5.

“Water”, per M gallon.

Payment for “Water” is described in Section 2-07.5.

“Job Mix Compliance Price Adjustment”, by calculation.

CITY OF FEDERAL WAY

SP-90

**21ST AVE S & S 320TH STREET
SIGNALIZATION AND PEDESTRIAN
IMPROVEMENTS PROJECT
PROJECT #36225**

CFW SPECIAL PROVISIONS VER. 2023.06

*** PLAN CENTER COPY *** Official bid documents, plan holder's list, and addenda (if applicable) are available on BXWA.com

“Job Mix Compliance Price Adjustment” will be calculated and paid for as described in Section 5-04.3(9)C6.

“Compaction Price Adjustment”, by calculation.

“Compaction Price Adjustment” will be calculated and paid for as described in Section 5-04..3(10)D3.

“Roadway Core”, per each.

The Contractor’s costs for all other Work associated with the coring (e.g., traffic control) shall be incidental and included within the unit Bid price per each and no additional payments will be made.

“Cyclic Density Price Adjustment”, by calculation.

“Cyclic Density Price Adjustment” will be calculated and paid for as described in Section 5-04.3(10)B.

(April 12, 2018 CFW GSP)

Section 5-04.5 is supplemented with the following:

“Temporary Pavement”, per ton.

END OF DIVISION 5

CITY OF FEDERAL WAY

**21ST AVE S & S 320TH STREET
SIGNALIZATION AND PEDESTRIAN
IMPROVEMENTS PROJECT
PROJECT #36225**

SP-91

CFW SPECIAL PROVISIONS VER. 2023.06

***** PLAN CENTER COPY *** Official bid documents, plan holder's list, and addenda (if applicable) are available on BXWA.com**

DIVISION 6 STRUCTURES

6-06 Bridge Railings

6-06.5 Payment

Section 6-06.5 is supplemented with the following:

“44” Breakaway Cable Pedestrian Railing” per linear foot.

END OF DIVISION 6

CITY OF FEDERAL WAY

**21ST AVE S & S 320TH STREET
SIGNALIZATION AND PEDESTRIAN
IMPROVEMENTS PROJECT
PROJECT #36225**

SP-92

CFW SPECIAL PROVISIONS VER. 2023.06

***** PLAN CENTER COPY *** Official bid documents, plan holder's list, and addenda (if applicable) are available on BXWA.com**

**DIVISION 7
DRAINAGE STRUCTURES, STORM SEWERS,
SANITARY SEWERS, WATER MAINS, AND CONDUITS**

7-05 MANHOLES, INLETS, CATCH BASINS, AND DRYWELLS

7-05.3 Construction Requirements

7-05.3(1) Adjusting Manholes, Valve Boxes and Catch Basins to Grade
(April 12, 2018 CFW GSP)

Section 7-05.3 is supplemented with the following:

Manholes, valve boxes, catch basins, and other structures shall not be adjusted to final grade until the adjacent pavement is completed, at which time the center of each structure shall be carefully relocated from references previously established by the Contractor. The asphalt concrete pavement shall be removed to a neat circular shape for circular grates and covers and a neat rectangular shape for rectangular grates and covers. The edge of the cut shall be 1.5 feet from the outside edge of the cast iron frame of the structure. The base materials and crushed rock shall be removed to the full depth of adjustment plus 2 inches. The manhole and catch basin frames shall be lifted and reset to the final grade, plumb to the roadway, and shall remain operational and accessible. (Reference City of Federal Way Standard Drawing 3-55 for Utility Adjustment).

The Contractor shall adjust manholes and catch basins with pre-cast grade rings, and mortar and high impact adjustment risers with a maximum 2-inch thickness where required for heavy-duty frames and covers within the travelled roadway. Metal adjustment rings shall not be used. If more than three grade rings are required to adjust a manhole or Type 2 catch basin to final grade, including existing grade rings, the Contractor shall remove the existing cone section or top slab, install a pre-cast manhole section of sufficient height to limit the number of grade rings to a maximum of three, and reinstall the cone section or top slab prior to paving operations. Grade adjustment rings and high impact riser installation shall be inspected by the Engineer prior to frame installation. Cover and grate frames shall be securely grouted to the structure.

Where existing structures are located within the wheel path of a proposed travel lane, catch basins adjusted to grade shall also include conversion risers and heavy duty locking frames and covers and high-impact risers.

Following frame installation, the edges of the removed asphalt pavement and the outer edge of the reset frame shall be painted with asphalt for tack coat. The entire void around the adjustment shall then be filled with Commercial HMA, placed and compacted in maximum 3-inch lifts, to match the adjacent pavement surface. The joint between the patch and existing pavement shall then be painted with asphalt for tack coat and immediately covered with dry paving sand before the asphalt for tack coat solidifies.

CITY OF FEDERAL WAY

**21ST AVE S & S 320TH STREET
SIGNALIZATION AND PEDESTRIAN
IMPROVEMENTS PROJECT
PROJECT #36225**

SP-93

CFW SPECIAL PROVISIONS VER. 2023.06

*** PLAN CENTER COPY *** Official bid documents, plan holder's list, and addenda (if applicable) are available on BXWA.com

7-05.3(6) Cleaning
(April 12, 2019 CFW GSP)

Section 7-05.3(6) is a new section:

Prior to final project acceptance by the City, the Contractor shall be responsible to ensure the sumps of all manholes, inlets, catch basins, and drywells are clean of sediment and debris.

7-05.5 Payment
(December 16, 2022 CFW GSP)

Section 7-05.5 is supplemented with the following:

The unit contract price for “Adjust Manhole” and/or “Adjust Catch Basin” and/or “Adjust Inlet” applies to existing storm drainage catch basins, inlets, and manholes that require adjustment to grade by addition or removal of adjustment risers. The unit contract price includes all labor, tools, equipment, and materials necessary to adjust drainage structures to finished grade, sawcutting, temporary patching hot mix to allow for the passage of traffic, restoration of the area around the adjusted structure, and providing new rings and covers or frames and grates. Conversion of catch basin/manhole/inlet lids (i.e. convert to heavy duty, solid, round locking lid) shall be included in this bid item. Grade rings and adjustment risers (concrete or high-impact) shall be considered incidental to this bid item and will not be measured for separate payment. Payment will be made once the adjustment is fully complete and grouted. Partial payment will not be made if risers have been added, but the grouting has not been completed to the satisfaction of the City.

7-07 CLEANING EXISTING DRAINAGE STRUCTURES

7-07.5 Payment
(April 12, 2018 CFW GSP)

Section 7-07.5 is replaced with the following:

All costs associated with cleaning existing drainage structures shall be considered incidental to and included in the various bid items and no additional payment shall be made.

7-12 VALVES FOR WATER MAINS

7-12.4 Measurement
(December 1, 2021 CFW GSP)

Section 7-12.4 is supplemented with the following:

“Adjust Water Valve to Grade” will be measured per each.

7-12.5 Payment
(December 1, 2021 CFW GSP)

Section 7-12.5 is replaced with the following:

The unit contract price for “Adjust Water Valve to Grade” applies to existing water valves that require adjustment to grade. The unit contract price includes all labor, tools, equipment, and materials necessary to adjust valves to finished grade, sawcutting, temporary patching hot mix to allow for the passage of traffic, restoration of the area around the adjusted structure. Non-slip MMA coating for lids in accessible surfaces shall be considered incidental to this bid item and will

CITY OF FEDERAL WAY

21ST AVE S & S 320TH STREET
SIGNALIZATION AND PEDESTRIAN
IMPROVEMENTS PROJECT
PROJECT #36225

SP-94

not be measured for separate payment. Payment will be made once the adjustment is fully complete.

END OF DIVISION 7

CITY OF FEDERAL WAY

**21ST AVE S & S 320TH STREET
SIGNALIZATION AND PEDESTRIAN
IMPROVEMENTS PROJECT
PROJECT #36225**

SP-95

CFW SPECIAL PROVISIONS VER. 2023.06

***** PLAN CENTER COPY *** Official bid documents, plan holder's list, and addenda (if applicable) are available on BXWA.com**

DIVISION 8 MISCELLANEOUS CONSTRUCTION

8-01 EROSION CONTROL AND WATER POLLUTION CONTROL

8-01.3 Construction Requirements

8.01.3(1) General

(April 12, 2018 CFW GSP)

The first paragraph of 8-01.3(1) is deleted and replaced with the following:

The Contractor shall install a high visibility fence along the right-of-way lines shown in the Plans or as instructed by the Engineer.

8-01.3(1)A Submittals

(April 12, 2018 CFW GSP)

Section 8-01.3(1)A is revised to read:

A Stormwater Pollution Prevention Plan (SWPPP) shall be prepared by the Contractor and submitted for approval to the Engineer. The plan shall consist of the Contractor's complete strategy to meet the requirements of the Department of Ecology's NPDES and State Waste Discharge General Permit for Stormwater Discharges Associated With Construction Activity (General Permit). The SWPPP shall include and modify as necessary the Site Preparation and Erosion Control Plan drawings provided as part of the Contract Plans. The Contractor shall prepare review and modify the SWPPP as necessary to be consistent with the actual work schedule, sequencing, and construction methods that will be used on the project. The Contractor's SWPPP shall meet the requirements of the general permit. The Contractor's modifications to the SWPPP shall also incorporate the content and requirements for the Spill Prevention, Control and Countermeasures (SPCC) Plan in accordance with Section 1-07.15(1).

The SWPPP shall document all the erosion and sediment control Best Management Practices (BMPs) proposed, whether permanent or temporary. The plan shall document installation procedures, materials, scheduling, and maintenance procedures for each erosion and sediment control BMP. The Contractor shall submit the SWPPP for the Engineer's approval before any work begins. The Contractor shall allow at least five working days for the Engineer's review of the initial SWPPP or any revisions to the modified SWPPP. Failure to approve all or part of any such plan shall not make the Contracting Agency liable to the Contractor for any work delays. The Contractor may not begin work without an approved Contractor's SWPPP.

The Contractor shall complete and modify the SWPPP to meet the Contractor's schedule and method of construction. All TESC Plans shall meet the requirements of the current edition of the WSDOT Temporary Erosion and Sediment Control Manual M 3109 and be adapted as needed throughout construction based on site inspections and discharge samples to maintain compliance with the CSWGP. The Contractor shall develop a schedule for implementation of the SWPPP work and incorporate it into the Contractor's progress schedule.

CITY OF FEDERAL WAY

**21ST AVE S & S 320TH STREET
SIGNALIZATION AND PEDESTRIAN
IMPROVEMENTS PROJECT
PROJECT #36225**

SP-96

CFW SPECIAL PROVISIONS VER. 2023.06

In addition, the SWPPP shall outline the procedures to be used to prevent high pH stormwater or dewatering water from entering surface waters. The plan shall include how the pH of the water will be maintained between pH 6.5 and pH 8.5 prior to being discharged from the project or entering surface waters. Prior to beginning any concrete or grinding work, the Contractor shall submit the plan, for the Engineer's review and approval.

As a minimum, the SWPPP shall include all the SWPPP requirements identified in the General Permit, including:

Narrative discussing and justifying erosion control decisions (12 elements)

Drawings illustrating BMPs types and locations

Engineering calculations for ponds and vaults used for erosion control

A schedule for phased installation and removal of the proposed BMPs, including:

- A. BMPs that will be installed at the beginning of project startup.
- B. BMPs that will be installed at the beginning of each construction season.
- C. BMPs that will be installed at the end of each construction season.
- D. BMPs that will be removed at the end of each construction season.
- E. BMPs that will be removed upon completion of the project.

An Ecology template is available to the Contractor for producing the SWPPP, using project-specific information added by the Contractor. The template and instructions are available at:

<http://www.ecy.wa.gov/programs/wq/stormwater/construction/>

Turbidity and pH Exceedances

Following any exceedances of the turbidity or pH benchmarks, the Contractor shall provide the following at no additional cost to the Contracting agency:

1. The necessary SWPPP revisions and on-site measures/revisions including additional source control, BMP maintenance, and/or additional stormwater treatment BMPs that are necessary to prevent continued exceedance of turbidity and/or pH benchmarks.
2. The regulatory notification to the Dept. of Ecology and to the Engineer of any monitoring results requiring regulatory notification.
3. The additional daily sampling and reporting measures described in the General Permit to verify when project site runoff is in compliance.

8-01.3(1)B Erosion and Sediment Control (ESC) Lead ***(October 3, 2022 WSDOT GSP, OPTION 1)***

Item number 3 and 4 in the second paragraph of Section 8-01.3(1)B are revised to read:

CITY OF FEDERAL WAY

**21ST AVE S & S 320TH STREET
SIGNALIZATION AND PEDESTRIAN
IMPROVEMENTS PROJECT
PROJECT #36225**

SP-97

3. Submit to the Engineer no later than the end of the next working day following the inspection a TESC Inspection Report that includes:
 - a. When, where, and how BMPs were installed, maintained, modified, and removed.
 - b. Observations of BMP effectiveness and proper placement.
 - c. Recommendations for improving future BMP performance with upgraded or replacement BMPs when inspections reveal TESC BMP deficiencies.
 - d. Identify for each discharge point location whether there is compliance with state water quality standards in WAC 173-201A for turbidity and pH.

8-01.3(2) Seeding, Fertilizing, and Mulching

8-01.3(2)B Seeding and Fertilizing (September 3, 2019 WSDOT GSP, OPTION 3)

Section 8-01.3(2)B is supplemented with the following:

Grass seed shall be a commercially prepared mix, made up of low growing species which will grow without irrigation at the project location, and approved by the Engineer. The application rate shall be two pounds per 1000 square feet. Fertilizer shall be a commercially prepared mix of 10-20-20 and shall be applied at the rate of 10 pounds per 1000 square feet.

8-02 ROADSIDE RESTORATION

8-02.3 Construction Requirements

8-02.3(1) Responsibility During Construction (April 12, 2018 CFW GSP)

Section 8-02.3(1) is supplemented with the following:

Landscape construction is anticipated to begin after all curbs, sidewalks, walls, and associated roadside work is completed. Landscape materials shall not be installed until weather permits and installation has been authorized by the Engineer. If water restrictions are anticipated or in force, planting of landscape materials may be delayed.

Throughout planting operations, the Contractor shall keep the premises clean, free of excess soils, plants, and other materials, including refuse and debris, resulting from the Contractor's work. At the end of each work day, and as each planting area is completed, it shall be neatly dressed, and all surrounding walks and paved areas shall be cleaned to the satisfaction of the Engineer. No flushing will be allowed. At the conclusion of work, the Contractor shall remove surplus soils, materials, and debris from the construction site and shall leave the project in a condition acceptable to the Engineer.

8-02.3(8) Planting (March 22, 2023 CFW GSP)

CITY OF FEDERAL WAY

SP-98

21ST AVE S & S 320TH STREET
SIGNALIZATION AND PEDESTRIAN
IMPROVEMENTS PROJECT
PROJECT #36225

Section 8-02.3(8) is supplemented with the following:

All Topsoil Type A required to pit plant trees and bark mulch for topdressing, as specified in the plans, shall be considered incidental to and included in the unit contract price of the trees.

Use loosened and replaced compacted mineral native soil without organics under tree rootball. Use topsoil on sides of tree rootball only. Use full depth topsoil for shrubs.

Trees shall be handled by the rootball, not by the trunk. Burlap and wire shall remain intact until trees are set in their final positions within each planting pit.

Plant trees and shrubs upright and rotate in order to give the best appearance or relationship to adjacent plants, topography, and structures. Hold plant rigidly in position until topsoil has been backfilled and water settled free of voids and air pockets and tamped firmly around the ball or roots.

When the pit is backfilled halfway, place the specified quantity of fertilizer plant tablets and stakes as shown in the Plans. Evenly space the fertilizer tablets around the perimeter of, and immediately adjacent to the root system. Carefully place water and compact planting topsoil, filling all voids. Tree root crowns to be 1" higher than finished grade to allow for settlement.

When the planting pit is three quarters backfilled, fill with water and allow water to soak away. Fill the pits with additional topsoil to finish grade and continue backfilling as detailed in the Plans. Water trees immediately after planting.

The contractor shall apply 3 inches of pea gravel flush with bottom of tree grates in tree wells per City Standard Detail 3-31.

8-02.3(11) Bark or Wood Chip Mulch

(March 22, 2023 CFW GSP)

Section 8-02.3(11) is supplemented with the following:

Bark Mulch shall be placed over all tree planting pits to a depth no less than two (2) inches, or as detailed in the Plans. Thoroughly water and hose down plants with a fine spray to wash the leaves of the plants immediately after application.

8-02.3(17) Protection of Private Property and Property Restoration

(March 22, 2023 CFW GSP)

Section 8-02.3(17) is a new section:

Property Restoration shall consist of fine grading and restoration of adjacent landscaped areas; adjustment and/or replacement of private irrigation systems; slope restoration behind sidewalks; timber edgings; installing and replacing private wood and chain link fencing; and other work not currently identified in the plans, as directed by the Engineer.

The Contractor is specifically reminded that any unnecessary damage caused by construction activities will be repaired at the Contractor's expense.

Restore all disturbed areas to original condition or better. Grass areas shall be restored with hydroseed where directed.

Removal of tree roots outside the limits of construction, as directed by the Engineer and under the supervision of a certified arborist, shall be paid for under "Property Restoration".

Topsoil shall be Type A and mulch shall be Bark or Wood Chip Mulch, per these Special Provisions.

All materials shall conform to Sections 9-14 Erosion Control and Roadside Planting and 9-15 Irrigation System of the Standard Specifications.

The force account provided for property restoration also includes any adjustments and/or replacements of existing irrigation systems not covered under Section 8-03 Irrigation Systems of the Special Provisions. This work shall also consist of modifying existing landscape lighting systems as may become necessary by these improvements.

The Contractor is advised that protecting existing private irrigation and lighting systems from damage does not constitute a basis for claim or extra work.

8-02.4 Measurement

(April 12, 2018 CFW GSP)

Section 8-02.4 is supplemented with the following:

Topsoil, bark mulch, compost, and/or soil amendments will be measured by the cubic yard in the haul conveyance at the point of delivery.

"Property Restoration" will be paid by force account and must be approved by the engineer prior to completing the work.

8-02.5 Payment

(April 12, 2018 CFW GSP)

Section 8-02.5 is supplemented with the following:

"Bark Mulch" per cubic yard. The unit contract price shall be full pay for furnishing and spreading the mulch.

"Property Restoration" per force account.

8-03 IRRIGATION SYSTEMS

8-03.3 Construction Requirements

(April 12, 2018 CFW GSP)

Section 8-03.3 is supplemented with the following:

All work shall be in strict conformance with the Lakehaven Utility District Water System and Sewer Standards, together with the plans, details and manufacturer's written information regarding recommended installation procedures. References to the use of galvanized pipe in the Standard Specifications and Amendments shall be replaced with Schedule 80 PVC or other Engineer accepted pipe material.

CITY OF FEDERAL WAY

**21ST AVE S & S 320TH STREET
SIGNALIZATION AND PEDESTRIAN
IMPROVEMENTS PROJECT
PROJECT #36225**

SP-100

CFW SPECIAL PROVISIONS VER. 2023.06

***** PLAN CENTER COPY *** Official bid documents, plan holder's list, and addenda (if applicable) are available on BXWA.com**

Private sprinkler irrigation systems found to encroach within the limits of improvements shall be modified as necessary to remove the encroachment and to ensure satisfactory operation of the remaining system. The Contractor shall ensure that existing private systems remain in operation during the construction of this project. The Contractor shall furnish temporary water to disconnected existing irrigation systems. Private irrigation systems that have been damaged during construction activities shall be repaired within 5 working days. The Contractor shall be liable for any damage due to irrigation facilities damaged by his operations and shall repair such damaged facilities to an "equal or better than" original condition. This work will include, but not be limited to, cutting and capping existing pipe, relocating existing risers and sprinkler heads new pipe heads and connections, and testing of the system. Payment will be by Force Account for Property Restoration.

8-04 CURBS, GUTTERS, AND SPILLWAYS

8-04.3 Construction Requirements ***(March 22, 2023 CFW GSP)***

Section 8-04.3 is supplemented with the following:

The sub-base for curb and gutter sections shall be compacted to 95 percent density at or below optimum moisture content, as per Section 2-03.3(14)D revised, before placing the curb and gutter.

White-pigmented curing compounds will not be allowed.

The top of the finished concrete shall not deviate more than one-eighth (1/8") in ten feet (10') or the alignment one-fourth (1/4") in ten feet (10').

Where shown in the Plans, the concrete curb will be ramped for wheel chairs as shown in the City Standard Plan Details.

Where shown in the plans, the Contractor shall paint the curbs with 2-coats of yellow paint. Paint and application shall conform to the Standard Specifications for traffic paint striping.

8-04.3(1) Cement Concrete Curbs, Gutters, and Spillways ***(December 16, 2022 CFW GSP)***

Section 8-04.3(1) is supplemented with the following:

The concrete class requirements in paragraph one are applicable for Type I/II Portland cement. See Section 9.01.2(1)B for requirements for Type 1L cement.

8-04.4 Measurement

(April 12, 2018 CFW GSP)

Section 8-04.4 is supplemented with the following:

Painting of curbs, where required, will not be measured and is considered incidental to the unit price of the type of curb.

8-04.5 Payment

(April 12, 2018 CFW GSP)

Section 8-04.5 is supplemented with the following:

CITY OF FEDERAL WAY

21ST AVE S & S 320TH STREET
SIGNALIZATION AND PEDESTRIAN
IMPROVEMENTS PROJECT
PROJECT #36225

SP-101

“Extruded Curb, Type 6”, per linear foot.

“Double Wide Extruded Cement Concrete Curb”, per linear foot.

8-07 PRECAST TRAFFIC CURB

8-07.1 Description

(December 12, 2012 CFW GSP)

Section 8-07.1 is deleted and replaced with the following:

This Work consists of furnishing and installing precast traffic curb, block traffic curb, sloped mountable curb, or dual faced sloped mountable curb of the design and type specified in the Plans in accordance with these Specifications and the Standard Plans, in the locations indicated in the Plans or as identified by the Engineer.

8-07.2 Materials

(August 9, 2014 CFW GSP)

Section 8-07.2 is supplemented with the following:

Block Traffic Curb 9-18.3

8-09 RAISED PAVEMENT MARKERS

8-09.1 Description

(December 12, 2012 CFW GSP)

Section 8-09.1 is supplemented with the following:

RPM's shall be installed per City of Federal Way Standard Details.

8-14 CEMENT CONCRETE SIDEWALKS

8-14.2 Materials

(December 16, 2022 CFW GSP)

Section 8-14.2 is supplemented with the following:

The Cement Concrete Sidewalk and curb ramps shall be constructed of Class 4000 concrete or greater if Type I/II Portland cement is used. If Type 1L Blended hydraulic cement is used, see 9-01.2(1)B.

8-14.3 Construction Requirements

(December 16, 2022 CFW GSP)

Section 8-14.3 is supplemented with the following :

The concrete class requirements in paragraph one are applicable for Type I/II Portland cement. See Section 9.01.2(1)B for requirements for Type 1L cement.

(April 3, 2017 WSDOT GSP, OPTION 1)

Section 8-14.3 is supplemented with the following :

The Contractor shall request a pre-meeting with the Engineer to be held 2 to 5 working days before any work can start on cement concrete sidewalks, curb ramps or other pedestrian access routes to discuss construction requirements. Those attending shall include:

CITY OF FEDERAL WAY

**21ST AVE S & S 320TH STREET
SIGNALIZATION AND PEDESTRIAN
IMPROVEMENTS PROJECT
PROJECT #36225**

SP-102

1. The Contractor and Subcontractor in charge of constructing forms, and placing, and finishing the cement concrete.
2. Engineer (or representative) and Project Inspectors for the cement concrete sidewalk, curb ramp or pedestrian access route Work.

Items to be discussed in this meeting shall include, at a minimum, the following:

1. Slopes shown on the Plans
2. Inspection
3. Traffic control
4. Pedestrian control, access routes and delineation
5. Accommodating utilities
6. Form work
7. Installation of detectable warning surfaces
8. Contractor ADA survey and ADA Feature as-built requirements
9. Cold Weather Protection

(January 7, 2019 WSDOT GSP, OPTION 2)

Section 8-14.3 is supplemented with the following:

Timing Restrictions

Curb ramps shall be constructed on one leg of the intersection at a time. The curb ramps shall be completed and open to traffic within five calendar days before construction can begin on another leg of the intersection unless otherwise allowed by the Engineer.

Unless otherwise allowed by the Engineer, the five calendar day time restriction begins when an existing curb ramp for the quadrant or traffic island/median is closed to pedestrian use and ends when the quadrant or traffic island/median is fully functional and open for pedestrian access.

(January 7, 2019 WSDOT GSP, OPTION 3)

Section 8-14.3 is supplemented with the following:

Layout and Conformance to Grades

Using the information provided in the Contract documents, the Contractor shall layout, grade, and form each new curb ramp, sidewalk, and curb and gutter.

(March 22, 2023 CFW GSP)

Section 8-14.3 is supplemented with the following :

Cement concrete sidewalk thickness shall be as shown in the Plans. Score joints shall be constructed at a maximum distance of 5 feet from each full depth expansion joint, except where specific dimensions are detailed in the Plans. Asphalt mastic joint fillers in the sidewalk shall be 3/8" x 4" and of the same material as that used in the curb, and shall be placed in the same location as that in the curb.

No concrete for sidewalk shall be poured against dry forms or dry subgrade.

CITY OF FEDERAL WAY

**21ST AVE S & S 320TH STREET
SIGNALIZATION AND PEDESTRIAN
IMPROVEMENTS PROJECT
PROJECT #36225**

SP-103

CFW SPECIAL PROVISIONS VER. 2023.06

The Contractor may provide suitable vibrating finishers for use in finishing concrete sidewalks. The type of vibrator and its method of use shall be subject to the approval of the City.

All completed work shall be so barricaded as to prevent damage. Any damaged sections shall be removed and replaced at the Contractor's expense. Landscaped areas disturbed during construction shall be restored to original condition at the Contractor's expense.

Scored Cement Concrete Sidewalk shall be broom finished and scored as detailed in the Plans.

*(***PROJECT-SPECIFIC SPECIAL PROVISION***)*

Replace the third paragraph of Section 8-14.4 with the following:

Detectable warning surfaces, not part of ramps, will be measured by the square foot of cast in place detectable warning surfaces constructed as shown in the Plans.

8-14.3(5)C Surface Applied Detectable Warning Surface
(December 16, 2022 CFW GSP)

Section 8-14.3(5)C is replaced with the following :

Glued or stick down Detectable Warning Surfaces are allowed on asphalt surfaces only for temporary work zone applications.

MMA-Style Truncated Dome Detectable Warning Surfaces applied to asphalt surfaces for permanent installations shall be liquid-applied Vanguard ADA Systems, or approved equal.

8-14.5 Payment

(April 12, 2018 CFW GSP)

Section 8-14.5 is supplemented with the following:

Payment for "Cement Conc. Curb Ramp Type ____" will not be made until the City has verified that the ramp(s) meet ADA requirements.

*(***PROJECT-SPECIFIC SPECIAL PROVISION***)*

Replace the last paragraph of Section 8-14.5 with the following:

The unit Contract price per square foot of "Detectable Warning Surface", shall be full pay for cast in place detectable warning surfaces, not constructed as part of ramps.

8-20 ILLUMINATION. TRAFFIC SIGNAL SYSTEMS. INTELLIGENT TRANSPORTATION SYSTEMS. AND ELECTRICAL

8-20.1 Description

8-20.1(1) Regulations and Code

(March 13, 2012 CFW GSP)

Section 8-20.1(1) is supplemented with the following:

CITY OF FEDERAL WAY

21ST AVE S & S 320TH STREET
SIGNALIZATION AND PEDESTRIAN
IMPROVEMENTS PROJECT
PROJECT #36225

SP-104

Where applicable, materials shall conform to the latest requirements of Puget Sound Energy and the Washington State Department of Labor and Industries.

8-20.1(2) Industry Codes and Standards

(March 13, 2012 CFW GSP)

The following is added at the end of the first paragraph of this section:

National Electrical Safety Code (NESC) Committee, IEEE Post Office Box 1331445 Hoes Lane, Piscataway, NJ 08855-1331.

8-20.1(3) Permitting and Inspections

(April 12, 2018 CFW GSP)

Section 8-20.1(3) is supplemented with the following:

The Contractor shall be responsible for obtaining all required electrical permits, including all required City electrical permits. All costs to obtain and comply with electrical permits shall be included in the applicable bid items for the work involved.

8-20.2 Materials

Section 8-20.2 is supplemented with the following:

(March 13, 2012 CFW GSP)

Control density fill shall meet the requirements of Washington Aggregates and Concrete Association.

Bedding material shall consist of 5/8-inch minus crushed rock free of any deleterious substances (Section 9-03.1(5)A of the Standard Specifications).

8-20.2(1) Equipment List And Drawings

(January 26, 2012 CFW GSP)

The first paragraph is deleted and replaced with the following:

Within one (1) week following the pre-construction conference, the Contractor shall submit to the Engineer a completed "Request for Approval of Materials" that describes the material proposed for use to fulfill the Plans and Specifications. Manufacturer's technical information shall be submitted for signal, Safe City Cameras and related equipment (Pan-Tilt-Zoom, Fisheye, Bullet and License Plate Reader), electrical and luminaire equipment, all wire, conduit, junction boxes, and all other items to be used on the project. Approvals by the Engineer must be received before material will be allowed on the job site. Materials not approved will not be permitted on the job site.

(March 13, 1995 WSDOT GSP, OPTION 3)

Section 8-20.2(1) is supplemented with the following:

If traffic signal standards, strain pole standards, or combination traffic signal and lighting standards are required, final verified dimensions including pole base to signal mast arm connection point, pole base to light source distances (H1), mast arm length, offset distances to mast arm mounted appurtenances, and orientations of pole mounted appurtenances will be furnished by the Engineer as part of the final approved shop drawings prior to fabrication.

8-20.3 Construction Requirements

CITY OF FEDERAL WAY

21ST AVE S & S 320TH STREET
SIGNALIZATION AND PEDESTRIAN
IMPROVEMENTS PROJECT
PROJECT #36225

SP-105

8-20.3(1) General
(January 26, 2012 CFW GSP)

Section 8-20.3(1) is supplemented with the following:

Contractor Owned Removals

All removals associated with an electrical system, which are not designated to remain the property of the Contracting Agency, shall become the property of the Contractor and shall be removed from the project.

The Contractor shall:

Remove all wires for discontinued circuits from the conduit system or as directed by the Engineer.

Remove elbow sections of abandoned conduit entering junction boxes or as directed by the Engineer.

Abandoned conduit encountered during excavation shall be removed to the nearest outlets or as directed by the Engineer.

Remove foundations entirely, unless the Plans state otherwise.

Backfill voids created by removal of foundations and junction boxes. Backfilling and compaction shall be performed in accordance with Section 2-09.3(1)E.

(January 26, 2012 CFW GSP)

Section 8-20.3(1) is supplemented with the following:

Signal Display Installation

Signal displays shall be installed no more than 30 days prior to scheduled signal turn on or changeover. Signal displays and reflectorized backplates when installed prior to signal turn-on or changeover shall be covered and not visible to vehicular traffic at any time.

(PROJECT-SPECIFIC SPECIAL PROVISION***)***

Section 8-20.3(1) is supplemented with the following:

Signal System Turn On

The Contractor shall provide a detailed work plan for the signal system turn on to be approved by the Engineer. They shall not deviate from the work plan without prior written approval from the Engineer. The work plan shall show the exact date of the signal system turn on.

The turn on of the signal equipment shall commence after 8:30 AM and be completed by 3:00 PM on the same day (unless as noted below). Turn ons must take place on Tuesday, Wednesday, or Thursday, unless otherwise approved by the Engineer. During turn on, traffic control shall be provided. The exact work plan and schedule for turn on shall be pre-approved by the Engineer.

Certain intersections may require a night-time turn on due to traffic volumes. If the City determines a night-time turn on is required, they will provide direction as to

CITY OF FEDERAL WAY

**21ST AVE S & S 320TH STREET
SIGNALIZATION AND PEDESTRIAN
IMPROVEMENTS PROJECT
PROJECT #36225**

SP-106

CFW SPECIAL PROVISIONS VER. 2023.06

the allowable hours of work. No additional payment will be made to the Contractor for a night-time switchover.

(December 17, 2012 CFW GSP)

Section 8-20.3(1) is supplemented with the following:

Fiber Optic Cable Service Outage Duration & Notification

The maximum allowable interruption to the operation of the existing fiber optic cable service is three days, including testing. Outages of fiber optic cable may affect multiple parties, including but not limited to, the City, King County, and/or WSDOT. Proposed outage dates shall be reviewed and approved by the City. The City shall coordinate the outage with WSDOT. The Contractor shall coordinate the outage with King County Metro and King County Traffic at least two (2) weeks in advance of the proposed outage. The notification shall include description of work, location, duration of outage including start and ending date/time and emergency contact information. Notification in writing shall be sent to the following:

Owen Kehoe
King County Metro
Phone: 206-477-5811
Email: owen.kehoe@kingcounty.gov

Jeffery Barnett
King County Metro
Phone: 206-263-7826
Email: Jeffery.Barnett@kingcounty.gov

King County Signal Shop
Attn: Mark Parrett
155 Monroe Avenue NE
Renton, Washington 98056
Phone: 206-396-3763

8-20.3(2) Excavating and Backfilling

(March 22, 2023 CFW GSP)

Section 8-20.3(2) is supplemented with the following:

The Contractor shall supply all trenching necessary for the complete and proper installation of the traffic signal system, interconnect conduit and wiring, and illumination system.

Trenching shall conform to the following:

1. In paved areas, edges of the trench shall be sawcut the full depth of the pavement and sawcuts shall be parallel. All trenches for placement of conduit shall be straight and as narrow in width as practical to provide a minimum of pavement disturbance. The existing pavement shall be removed in an approved manner. The trench bottom shall be graded to provide a uniform grade.

2. Bedding and backfill materials for electrical trenches shall be as follows:

Electrical conduit trench depth shall be a minimum of 24 inches cover over conduits.

CITY OF FEDERAL WAY

**21ST AVE S & S 320TH STREET
SIGNALIZATION AND PEDESTRIAN
IMPROVEMENTS PROJECT
PROJECT #36225**

SP-107

CFW SPECIAL PROVISIONS VER. 2023.06

Bedding material for trenches 18 inches or less in width shall be crushed surfacing top course. Bedding material for trenches greater than 18 inches or for joint utility trenches shall be pit run sand. Bedding material shall be placed two inches below the conduit(s) and shall extend to two inches above the conduit(s).

Backfill material for trenches located within the roadway limits (back of curb to back of curb), including perpendicular crossings of roadways and underneath driveways shall be controlled density fill (CDF), vibrated in place.

Backfill material for trenches located outside of roadway and driveway limits shall be Bank Run Gravel for Trench Backfill conforming to WSDOT 9-03.19, unless the engineer determines that native material is suitable.

3. Backfill shall be carefully placed so that the backfilling operation will not disturb the conduit in any way. The backfill shall be thoroughly mechanically tamped in eight-inch (8") layers with each layer compacted to ninety-five percent (95%) of maximum density in traveled ways, and ninety percent (90%) of maximum density elsewhere at optimum soil moisture content.

Excavation for foundations shall be completed by vector excavation. This excavation shall be incidental to the signal or illumination bid items.

Underground utilities of record are shown on the construction Plans insofar as information is available. These, however, are shown for convenience only and the City assumes no responsibility for improper locations or failure to show utility locations on the construction Plans.

The location of existing underground utilities, when shown in the Plans, is approximate only, and the Contractor shall be responsible for determining their exact location. The Contractor shall check with the utility companies concerning any possible conflict prior to commencing excavation in any area, as not all utilities may be shown in the Plans.

The Contractor shall be responsible for potholing for conflicts with underground utility locations prior to determining exact locations of signal and luminaire pole foundations, underground vaults and directional boring operations. Prior to construction, if any conflicts are expected, it shall be brought to the attention of the Engineer for resolution.

The Contractor shall be entirely responsible for coordination with the utility companies and arranging for the movement or adjustment, either temporary or permanent, of their facilities within the project limits.

If a conflict is identified, the Contractor shall contact the Engineer. The Contractor and City shall locate alternative locations for poles, cabinet, or junction boxes. The

CITY OF FEDERAL WAY

**21ST AVE S & S 320TH STREET
SIGNALIZATION AND PEDESTRIAN
IMPROVEMENTS PROJECT
PROJECT #36225**

SP-108

CFW SPECIAL PROVISIONS VER. 2023.06

***** PLAN CENTER COPY *** Official bid documents, plan holder's list, and addenda (if applicable) are available on BXWA.com**

Contractor shall get approval from the Engineer prior to installation. The Contractor may consider changing depth or alignment of conduit to avoid utility conflicts.

Before beginning any excavation work for foundations, vaults, junction boxes or conduit runs, the contractor shall confirm that the location proposed on the Contract Plans does not conflict with utility location markings placed on the surface by the various utility companies. If a conflict is identified, the following process shall be used to resolve the conflict:

1. Contact the Engineer and determine if there is an alternative location for the foundation, junction box, vault or conduit trench.
2. If an adequate alternate location is not obvious for the underground work, select a location that may be acceptable and pothole to determine the exact location of other utilities. Potholing must be approved by the Engineer.
3. If an adequate alternate alignment still cannot be identified following potholing operations, the pothole area should be restored and work in the area should stop until a new design can be developed.

The Contractor shall not attempt to adjust the location of an existing utility unless specifically agreed to by the utility owner.

8-20.3(4) Foundations
(March 22, 2023 CFW GSP)

Section 8-20.3(4) is supplemented with the following:

The concrete class requirements in paragraph one are applicable for Type I/II Portland cement. See Section 9.01.22(1)B for requirements for Type 1L cement.

Excavation for foundations shall be completed by vector excavation. This excavation shall be incidental to the signal or illumination bid items.

Pole foundations within the sidewalk area shall be constructed in a single pour to the bottom of the cement concrete sidewalk. The sidewalk shall be constructed in a separate pour.

Pole foundations not within the sidewalk area shall incorporate a 3-foot by 3-foot by 4-inch-thick cement concrete pad set flush with the adjacent ground. Where the pad abuts a sidewalk, the pad shall extend to the sidewalk and the top of the pad shall be flush with the sidewalk. A construction joint shall be provided between the two units.

The foundation for the controller and service cabinets shall conform to the detail in the Plans. Conduits shall be centered horizontally except service conduit, which shall be placed at the side of the power panel.

Foundations for Type I traffic signal poles shall conform to Standard Plan J-21.10.

Foundations for Type II and Type III traffic signal poles shall conform to details on the Signal Standard Sheet in the Plans.

CITY OF FEDERAL WAY

SP-109

**21ST AVE S & S 320TH STREET
SIGNALIZATION AND PEDESTRIAN
IMPROVEMENTS PROJECT
PROJECT #36225**

CFW SPECIAL PROVISIONS VER. 2023.06

*** PLAN CENTER COPY *** Official bid documents, plan holder's list, and addenda (if applicable) are available on BXWA.com

Foundations for streetlight poles shall conform to City of Federal Way Drawing Number 3-39 except that foundation depth shall be as noted on the Illumination Pole Schedule.

Foundations for the decorative streetlight poles shall conform to City of Federal Way Drawing Number 3-43 except that foundation depth shall be as noted on the Illumination Pole Schedule.

8-20.3(4A) Controller Foundations
(March 22, 2023 CFW GSP)

Section 8-20.3(4)A is a new section:

The controller foundation shall conform to the City of Federal Way's Drawing No. 3-45B and 3-45C included in the Appendix of these Specifications.

Additionally, the pad mount shall conform to the following:

1. The concrete pedestal height shall be 20 inches.
2. The spare two-inch conduit shall run to the nearest junction box, unless placement of such would exceed the junction box capacity in which case the spare two-inch conduit shall run to the next nearest junction box.
3. Conduits shall be centered horizontally except service conduit which shall be placed at the side of the power panel.
4. Pedestal shall be tapered from top to bottom at 1:10 on all four sides.
5. Unit shall be mounted on a cement concrete pad per Plan Details.
6. Conduits shall be placed in the front 1/3 of the foundation. Foundations constructed with conduits located within the three (3) inch cabinet mounting flange shall be removed and reconstructed. Modification of the three (3) inch cabinet mounting flange will not be accepted.

The service cabinet foundation shall also be constructed on the larger cement concrete pad noted in the Plans and shall conform to the City of Federal Way's Drawing No. 3-45 included in the Appendix of these Specifications.

8-20.3(5) Conduit

8-20.3(5)A General
(March 16, 2011 CFW GSP)

Section 8-20.3(5) is supplemented with the following:

All conduit trenches shall be straight and as narrow in width as is practical to provide a minimum of pavement disturbance.

When conduit risers are installed, they shall be attached to the pole every 4 feet and shall be equipped with weather heads.

Conduit for the service wires between the Puget Sound Energy pole and the service panel and all above ground conduit shall be hot-dip galvanized rigid steel.

All conduits shall be clearly labeled at each junction box, handhole, vault or other utility appurtenance. Labeling shall be permanent and shall consist of the owner/type name and a unique conduit number or color. The owner name shall be

CITY OF FEDERAL WAY

**21ST AVE S & S 320TH STREET
SIGNALIZATION AND PEDESTRIAN
IMPROVEMENTS PROJECT
PROJECT #36225**

SP-110

CFW SPECIAL PROVISIONS VER. 2023.06

approved by the Engineer prior to starting work. The recommended owner/type abbreviations are:

PSE – Puget Sound Energy
QWEST – Qwest
COMCAST(AT&T)/C – Cable
COMCAST(AT&T)/F – Fiber
SIC – City Signal Interconnect
City Spare – City spares
Cobra – COBRA luminaire system

Traffic signal interconnect shall be placed, wherever feasible, in the joint utility trench being constructed under this contract (if applicable). This work shall be coordinated with the other utilities to ensure a 2" minimum conduit is provided solely for the traffic signal interconnect. Conduit size shall be verified with City Traffic Engineer prior to installation.

8-20.3(5)B Conduit Type

(March 16, 2011 CFW GSP)

Section 8-20.3(5)B is supplemented with the following:

All conduits for signal cable raceways under driveways shall be rigid galvanized steel or Schedule 80 polyvinyl chloride (PVC).

Whenever PVC conduit is used a ground wire shall be provided.

8-20.3(5)E3 Boring

Section 8-20.3(5)E3 is supplemented with the following:

*(***PROJECT-SPECIFIC SPECIAL PROVISION***)*

Should the contractor elect to utilize a boring method of installation for locations not required for directional boring, they shall first obtain approval by the City before proceeding. The City reserves the right to require open trench excavation unless otherwise noted.

A complete set of as-built plans showing all bores (successful and failed) within 10 calendar days of completing the boring shall be submitted to the Engineer. The plans shall be copies of the Contract Plans and include roadway profile, cross-section, boring location and subsurface conditions. The plans must include elevations of the installation.

8-20.3(5)E4 Directional Boring

Section 8-20.3(5)E4 is supplemented with the following:

*(***PROJECT-SPECIFIC SPECIAL PROVISION***)*

All conduit crossings of S 320th Street or for conduits runs within 15 feet of the centerline of S 320th Street shall be by directional boring. No open cut trenching will be allowed.

8-20.3(6) Junction Boxes, Cable Vaults, and Pull Boxes

(March 22, 2023 CFW GSP)

Section 8-20.3(6) is supplemented with the following:

CITY OF FEDERAL WAY

21ST AVE S & S 320TH STREET
SIGNALIZATION AND PEDESTRIAN
IMPROVEMENTS PROJECT
PROJECT #36225

SP-111

CFW SPECIAL PROVISIONS VER. 2023.06

*** PLAN CENTER COPY *** Official bid documents, plan holder's list, and addenda (if applicable) are available on BXWA.com

Unless otherwise noted in the Plans or approved by the Engineer, junction boxes, cable vaults and pull boxes shall not be placed within the traveled way or shoulders.

All junction boxes, cable vaults, and pull boxes placed within the traveled way or paved shoulders shall be heavy-duty. Standard Duty nonconcrete junction boxes shall not be installed within the City of Federal Way.

Junction boxes shall not be located within the traveled way, wheelchair ramps, or driveways, or interfere with any other previous or relocated installation. The lid of the junction box shall be flush with the surrounding area and be adequately supported by abutting pavements or soils.

All streetlight junction boxes not placed in the sidewalk shall be placed immediately adjacent to a sidewalk or curb surrounded by concrete (or asphalt if adjacent to roadway) to prevent the box from lifting out of the dirt.

All streetlight junction box lids shall be welded shut after final inspection and approval by King County.

All lids located within sidewalk areas, along an ADA pedestrian route, or in other accessible surfaces within the public right-of-way or on publicly owned properties, must meet ADA requirements and be slip-resistant. Acceptable slip-resistant products shall be non-slip Methyl methacrylate (MMA) coating. Placement of the non-slip MMA coating shall be in accordance with the manufacturer's recommendations. Vertical edges of the utility shall be flush with the adjoining surface to the extent possible after installation.

Wiring shall not be pulled into any conduit until all associated junction boxes have been adjusted to, or installed in, their final grade and location, unless installation is necessary to maintain system operation. If wire is installed for this reason, sufficient slack shall be left to allow for future adjustment.

Wiring shall be replaced for full length if sufficient slack as specified in Section 8-20.3(8) is not maintained. No splicing will be permitted.

Junction boxes Type 1 and 2 shall meet the requirements of WSDOT Standard Plan J-40.10. Type 8 junction boxes shall meet the requirements of WSDOT Standard Plan J-40.30. Junction boxes shall be inscribed based upon system per WSDOT Standard Plan J-40.30. Junction box lids and frames shall be grounded per Section 8-20.3(9).

Junction boxes shall be located at the station and offset indicated in the Plans except that field adjustments may be made at the time of construction by the Engineer to better fit existing field conditions.

Junction boxes for copper and/or fiber signal interconnect shall be placed at a maximum interval of 300 feet and shall be inscribed with "TS" as described on WSDOT Standard Plan J-40.30.

CITY OF FEDERAL WAY

**21ST AVE S & S 320TH STREET
SIGNALIZATION AND PEDESTRIAN
IMPROVEMENTS PROJECT
PROJECT #36225**

SP-112

CFW SPECIAL PROVISIONS VER. 2023.06

*** PLAN CENTER COPY *** Official bid documents, plan holder's list, and addenda (if applicable) are available on BXWA.com

Communications/fibers vaults shall be provided for the purpose of storing slack cabling and installing splice enclosures. The location of all communication vaults shall be as indicated in the Plans and shall be field verified by the Contractor.

Communication/fibers vaults shall be configured such that the tensile and bending limitations of the fiber optic cable are not compromised. Vaults shall be configured to mechanically protect the fiber optic cable against installation force as well as inert forces after cable pulling operations.

Where indicated in the Plans, new vaults shall be installed as described herein and shown in the Plans. The Contractor shall furnish and install racking hardware for cable storage in all new vaults and in all existing vaults where cable storage is identified in the plans. The Contractor shall secure and store the cable in the racking hardware per manufacturer's instruction.

Fiber vaults shall be installed in accordance with the following:

1. All openings around conduits shall be sealed and filled with grout to prevent water and debris from entering the vaults or pull boxes. The grout shall meet the specifications of the fiber vault manufacturers.
2. Backfilling around the work shall not be allowed until the concrete or mortar has set.
3. Upon acceptance of work, fiber vaults shall be free of debris and ready for cable installation. All grounding requirements shall be met prior to cable installation.
4. Fiber vaults shall be adjusted to final grade using risers or rings manufactured by the fiber vault and pull box manufacturer. Fiber vaults with traffic bearing lids shall be raised to final grade using ring risers to raise the cover only. All voids created in and around the vault while adjusting it to grade shall be filled with grout.
5. Fiber vaults shall be installed at the approximate location shown in the Drawings. Final location to be approved by the Engineer.
6. All existing conduits will need to be open and exposed for access within the vault. Care shall be taken to identify which conduits have existing cables. All conduits will extend 2 inches within the vault walls. At the 2-inch mark the excess conduit on the existing structure will need to be removed and all cables exposed.
7. Once the conduits are located, excavate a hole large enough to install the fiber vault. The vault shall have a concrete floor as indicated on the Drawings. The floor shall be installed on 6 inches of crushed surfacing top course. If a fiber vault is installed outside a paved area, an asphalt pad shall be constructed surrounding the junction box. Ensure that the existing conduits are at a minimum of 4 inches above the top of the floor. If the

existing conduits contain existing cables, the new vault will need to be bottomless to allow the existing conduit and cable to be routed into the new vault.

(March 6, 2012 CFW GSP)

Section 8-20.3(8) is supplemented with the following:

Cable entering cabinets shall be neatly bundled and wrapped. Each wire shall bear the circuit number and be thoroughly tested before being connected to the appropriate terminal.

Circuit conductors shall be standard copper wire in all conduit runs with size specified in the Plans. Conductors from luminaire bases to the luminaire fixture shall be minimum No. 14 AWG pole and bracket cable.

(March 6, 2012 CFW GSP)

The following is inserted between the 3rd and 4th paragraph of this section:

Loop wires will be spliced to lead in wires at the junction box with an approved mastic tape, 3-M 06147 or equal, leaving 3 feet of loose wire.

Connectors will be copper and sized for the wire. Mastic splice material will be centered on the wire and folded up around both sides and joined at the top. Splice will then be worked from the center outward to the ends. The ends will be visible and fully sealed around the wire. The end of the lead-in cables shall have the sheathing removed 8 inches and shall be dressed external to the splice.

The 8th paragraph of this section is deleted and replaced with the following:

Fused quick disconnect kits shall be of the SEC type or equivalent. Underground illumination splices shall be epoxy or underground service buss/lighting connector kits. Installation shall conform to details in the Standard Plans.

The following is inserted between the 11th and 12th paragraphs of this section:

Field Wiring Chart (IMSA Standards)

501 +Input	506 AC+Control	511 Remote-All Red
502 AC-	507 AC+Crosswalk	512-520 Special
503 AC+Lights	508 AC+Detectors	551-562 Interconnect
504 AC+Lights	509 AC+12 Volts	593-598 Rail Road Preemption
505 AC+Lights	510 Remote-Flash	

Phases		1	2	3	4	5	6	7	8	A	B
Emergency Vehicle Preemption	Orange (B+)		581		584		587		590		
	Yellow (Call)		582		585		588		591		
	Blue (BB)		583		586		589		592		
Vehicle Heads	Red	611	621	631	641	651	661	671	681	691	601
	Orange	612	622	632	642	652	662	672	682	692	602
	Green	613	623	633	643	653	663	673	683	693	603
	Black	614	624	634	644	654	664	674	684	694	604
	White (Common)	616	626	636	646	656	666	676	686	696	606
Pedestrian Heads and PPB	Red (Hand)	711	721	731	741	751	761	771	781	791	701
	Green (Man)	712	722	732	742	752	762	772	782	792	702
	White (Common for Lights)	716	726	736	746	756	766	776	786	796	706
	Orange (Push button)	714	724	734	744	754	764	774	784	794	704
	Black (Common for Push button)	715	725	735	745	755	764	775	785	795	705
Vehicle Detectors	Loop 1	811	821	831	841	851	861	871	881	891	801
	Loop 1	812	822	832	842	852	862	872	882	892	802
	Loop 2	813	823	833	843	853	863	873	883	893	803
	Loop 2	814	824	834	844	854	864	874	884	894	804
	Loop 3	815	825	835	845	855	865	875	885	895	805
	Loop 3	816	826	836	846	856	866	876	886	896	806
	Loop 4	817	827	837	847	857	867	877	887	897	807
	Loop 4	818	828	838	848	858	868	878	888	898	808
Vehicle Detectors/ Count Loops	Loop 1	911	921	931	941	951	961	971	981	991	901
	Loop 1	912	922	932	942	952	962	972	982	992	902
	Loop 2	913	923	933	943	953	963	973	983	993	903
	Loop 2	914	924	934	944	954	964	974	984	994	904
	Loop 3	915	925	935	945	955	965	975	985	995	905
	Loop 3	916	926	936	946	956	966	976	986	996	906
	Loop 4	917	927	937	947	957	967	977	987	997	907
	Loop 4	918	928	938	948	958	968	978	988	998	908

8-20.3(8)A Copper Interconnect Cable Installation
(June 6, 2012 CFW GSP)

Section 8-20.3(8)A is a new section:

CITY OF FEDERAL WAY

21ST AVE S & S 320TH STREET
**SIGNALIZATION AND PEDESTRIAN
IMPROVEMENTS PROJECT
PROJECT #36225**

SP-115

Copper interconnect cable shall be 12 pair No. 19 AWG communications cable meeting IMSA Specification No. 40-20-1984. A 12 position terminal block shall be mounted on a panel on the rack on the interior side of the controller cabinet. Interconnect cables shall not be spliced or terminated except inside the traffic signal controller cabinet at terminal panel locations. Termination of copper interconnect cable shall be performed by a King County Signal technician. The contractor shall notify King County when cable is ready for terminations with a minimum of two working day's notice.

8-20.3(8)B Fiber Optic Cable Installation
(March 22, 2023 CFW GSP)

Section 8-20.3(8)B and all its subsections are new sections:

The fiber optic cable shall be singlemode cable conforming to the requirements of Section 9-29.3(1) Fiber Optic Cable and Section 9-29.3(1)A Singlemode Fiber Optic Cable. Fiber Optic Cable shall be Corning ALTOS All-Dielectric Cable or approved equal.

8-20.3(8)B1 Fiber Optic Cable Submittals

Submit the product data, samples, and qualification submittals specified below in one package at the same time. The Engineer's approval of any submitted documentation shall in no way relieve the Contractor from compliance with the safety and performance requirements as specified herein.

Submittals required by this item shall include, but not be limited to, the following:

- A. A material staging Plan, should the Contractor propose City owned property as a staging area.
- B. detailed fiber optic installation procedure including the following:
 - Fiber optic cable cutting lengths reflecting the cable order and reel allocations.
 - Cable pulling Plan which shall state the exact operational procedures to be utilized and which identifies the physical locations for equipment placement, proposed equipment setup at each location, pulling tension on all cables for each pull, staffing, and the pulling methodology for each type of cable.
 - Exact splice points as provided for herein.
- C. Product Data:
 1. Catalog sheets, specifications and installation instructions for all products.
 2. Complete manufacturer's construction details and specifications for the cables.Include for each type of cable:
 - a. Physical and optical characteristics of the optical fibers including cable manufacturer's certified test data (attenuation, bandwidth).
 - b. Physical characteristics of strength members, and jackets.
 - c. Maximum pulling strain allowed.
 - d. Crush resistance.
 - e. Overall dimension of cable.

CITY OF FEDERAL WAY

**21ST AVE S & S 320TH STREET
SIGNALIZATION AND PEDESTRIAN
IMPROVEMENTS PROJECT
PROJECT #36225**

SP-116

CFW SPECIAL PROVISIONS VER. 2023.06

***** PLAN CENTER COPY *** Official bid documents, plan holder's list, and addenda (if applicable) are available on BXWA.com**

D. Splicing and termination data, including the following:

1. List of materials.
2. Method of connecting cables.
3. Details of cable preparation.
4. Method of applying materials, including quantities.
5. Written statement from cable manufacturer that splices and terminations submitted are acceptable for use with their cable.
6. Written statement from cable manufacturer indicating recommended pulling compounds.

E. Cable Installer's Qualifications Data:

The persons installing the Work of this Section and their Supervisor shall be personally experienced in optical fiber cable systems and shall have been engaged in the installation of optical fiber cable systems for a minimum of 3 years. Qualifications shall be submitted to the Engineer at least 30 calendar days prior to the start of fiber installation for approval of qualifications.

1. The Contractor shall submit the name of each person who will be performing the Work and their employer's name, business address and telephone number.
2. The Contractor shall submit the name and addresses of 5 similar projects that the foregoing people have worked on during the past 3 years.

F. Cable Splicer's Qualifications Data:

Personnel that have at least three years field experience in single-mode fiber optic cable splicing shall accomplish all cable splicing. Qualifications shall be submitted to the Engineer at least 30 calendar days prior to the splicing for approval of qualifications.

1. Name of each person who will be performing the Work and their employer's name, business address and telephone number.
2. All information required showing that the experience criteria have been met.

List of Completed Installations: If brand names other than those specified are proposed for use, furnish the name, address, and telephone number of at least 5 comparable installations that can prove the proposed products have operated satisfactorily for one year.

8-20.3(8)B2 Fiber Optic Cable Installation

Pre-installation tests shall be conducted on the cable reels prior to installation. These tests shall be performed in accordance with EIA/TIA-455-78 for single-mode fibers using an optical time domain reflectometer (OTDR). Both ends of the cable shall be accessible for the tests, and it may be necessary to remove a portion of the protective wooden lagging on the reel.

Measurements shall be made using the 1310 nm and 1550 nm wavelengths or as specified by the City, and shall be compared to the factory test results. Any test that reveals the material does not meet the acceptable stated factory specifications shall constitute failure. A copy of these test results shall be provided to the City.

CITY OF FEDERAL WAY

21ST AVE S & S 320TH STREET
SIGNALIZATION AND PEDESTRIAN
IMPROVEMENTS PROJECT
PROJECT #36225

SP-117

CFW SPECIAL PROVISIONS VER. 2023.06

*** PLAN CENTER COPY *** Official bid documents, plan holder's list, and addenda (if applicable) are available on BXWA.com

The fiber optic cable shall not be installed prior to the installation of vaults, cabinets or pull points/junction boxes. Installation procedures shall be in conformance with the procedures specified by the cable manufacturer for the specific cable being installed.

The Contractor shall determine a suitable cable installation method to ensure that all cable installation requirements shall be met in all conduit sections. All work shall be carried out in accordance and consistent with the highest standards of quality and craftsmanship in the communication industry with regard to the electrical and mechanical integrity of the connections; the finished appearance of the installation; as well as the accuracy and completeness of the documentation.

The Contractor shall make a physical survey of the project site for the purpose of establishing the exact cable routing and cutting lengths prior to the commencement of any fiber optic work or committing any fiber optic materials. Unless otherwise directed by the Engineer, underground splicing of fiber optic cable in junction boxes or vaults will not be permitted. All termination splicing will take place in the traffic signal controller cabinets.

The cable shall be clearly marked with a permanent plastic tag in each junction box and vault it passes through and at each cable riser. The Contractor shall attach the cable to the racks and hooks with industry standard cable ties immediately upon entering the pull point/junction box. Each cable shall be looped and tied independently of one another. The fiber cable is to be routed in the top corners of vaults while ensuring proper bend radius. The cable is not to pass through any existing cable loop.

All work areas shall be clean and orderly at the completion of work and at times required by the Engineer during the progress of work.

Fiber Optic Cables shall be installed in continuous lengths without intermediate splices throughout the project, except at the location(s) specified in the Plans.

The Contractor shall comply with the cable manufacturer's specifications and recommended procedures including, but not limited to the following:

1. Installation.
2. Proper attachment to the cable strength elements for pulling during installation.
3. Bi-directional pulling.
4. Cable tensile limitations and the tension monitoring procedure.
5. Cable bending radius limitations.

The Contractor shall protect the loops from tangling or kinking. At no time during the length of the project shall the cable's minimum bending radius specifications be violated.

In all cable vaults and/or junction boxes designated in the plans, minimum cable slack of 15 yards shall be left by the Contractor, unless otherwise specified in the

CITY OF FEDERAL WAY

**21ST AVE S & S 320TH STREET
SIGNALIZATION AND PEDESTRIAN
IMPROVEMENTS PROJECT
PROJECT #36225**

SP-118

CFW SPECIAL PROVISIONS VER. 2023.06

***** PLAN CENTER COPY *** Official bid documents, plan holder's list, and addenda (if applicable) are available on BXWA.com**

plans. The cable slack length of fiber optic cable shall be coiled and secured with tie wraps to racking hardware or as specified in the plans.

The pulling eye/ sheath termination hardware on the fiber optic cables shall not be pulled over any sheave blocks.

When power equipment is used to install fiber optic cabling, the pulling speed shall not exceed 30 yards per minute. The pulling tension limitation for fiber optic cables shall not be exceeded under any circumstances.

Large diameter wheels, pulling sheaves and cable guides shall be used to maintain the appropriate bending radius. Tension monitoring shall be accomplished using commercial dynamometers or load-cell instruments.

Patch cords placed between pad mounted cabinets shall be protected by plastic spiral wrapping. Spiral wrap shall cover the entire length of the patch cord(s) to within 12 inches of end. The spiral wrap shall be installed before the patch cords are pulled into the conduit(s) and be rated for use in electrical installations.

During installation the Contractor shall keep a log that notes the length marking on the cable at every pull point/junction box. This will help determine the exact location of problems along the cable run during the OTDR testing.

The Contractor shall replace any damaged conductors or cables in occupied conduits as a result of Contractor's operations at the Contractor's cost.

8-20.3(8)B3 Fiber Optic Cable Splicing

This section describes the minimum requirements for splicing and connecting of the specified fiber optic cables.

Unless otherwise directed/approved by the Engineer, underground splicing of fiber optic cable in junction boxes or vaults will not be permitted. All termination splicing will take place in the traffic signal controller cabinets.

If approved by the Engineer, the fiber optic network may be spliced in fiber optic splice enclosures/vaults or as shown in the Plans. The Contractor shall use the fusion method with local injection and detection for all fiber optic splicing. All splices shall be securely stored in splice trays. Generally, splices shall not be performed in vaults smaller than 3'-6" x 3'-6" x 3'-6" (444-LA). When it is determined by the Engineer that a splice is performed in a vault smaller than 444-LA vault, appropriate slack coils will be provided to allow the splice case to be removed from the vault. When splicing is required in vaults (444-LA or larger), the splice case will be affixed to the side of the vault using the unistrut rack fasteners cast into the wall of the vault.

At least 2 feet (610 mm) of bare fiber shall be coiled and stored in the splice tray in a protected manner. At least 3 feet (914 mm) of each buffer tube in the fiber optic cable shall be coiled and stored in the splice enclosure or patch panel. All cables

shall be properly fastened to prevent against pulling out of the splice enclosure or patch panel.

All fusions shall be labeled with the fiber number using a pre-printed vinyl number tag. All splice trays shall be labeled with the range of fibers spliced in the tray. Cables at each location shall be designated with the next termination point at the other end of the cable.

All splicing in fiber optic splice enclosures shall be completed using "butt splicing".

The Contractor shall provide all required brackets and other racking hardware required for the fiber optic cable racking operations as specified.

All fusion splicing equipment shall be in good working order, properly calibrated, and meeting all industry standards and safety regulations. Splices shall utilize two half shells bolted together with stainless steel bolts and be fitted neoprene gasket. Selected splices shall not require a re-entry kit. Cable preparation, closure installation and splicing shall be accomplished in accordance with accepted and approved industry standards.

Upon completion of the splicing operation, all waste material shall be deposited in suitable containers for fiber optic disposal, removed from the job site, and disposed of in an environmentally acceptable manner.

The average splice loss of each fiber shall be 0.15 dB or less per splice. The average splice loss is defined as the summation of the attenuation as measured in both directions through the fusion splice, divided in half.

No individual splice loss measured in a single direction shall exceed 0.20 dB. The Contractor shall seal all cables where the cable jacket is removed. The cable shall be sealed per the cable manufacturer's recommendation with an approved blocking material.

If approved, all below ground splices shall be contained in waterproof splice enclosures. All splices shall be contained in splice trays utilizing strain relief, such as heatshrink wraps, as recommended by the splice tray manufacturer. Upon sealing the splice closure, the Contractor shall show that the closure maintains 68.4 kPa of pressure for a 24-hour period.

The fiber splice enclosure shall provide for the termination and protection of the fiber optic cable within the communications/fibers vaults. The fiber splice enclosure shall be installed per manufacturer's directions. The Contractor shall provide the splice enclosures and make splices at locations shown in the Plans. The Contractor shall test all fiber optic cables, splices, and connectors as shown in the Plans and as specified in these Special Provisions.

The splice enclosure shall be mounted to allow the cable to enter the enclosure without exceeding the cable manufacturer's minimum bending radius. Sufficient

CITY OF FEDERAL WAY

SP-120

**21ST AVE S & S 320TH STREET
SIGNALIZATION AND PEDESTRIAN
IMPROVEMENTS PROJECT
PROJECT #36225**

CFW SPECIAL PROVISIONS VER. 2023.06

***** PLAN CENTER COPY *** Official bid documents, plan holder's list, and addenda (if applicable) are available on BXWA.com**

cable shall be coiled with the splice enclosure to allow the enclosure to be removed from the vault or aerial span for splicing.

The unprotected fiber exposed for splicing within the enclosure shall be protected from mechanical damage using the fiber support tubes and shall be secured within the splice enclosure. The fibers shall be labeled with vinyl markers as directed by the City.

The enclosure shall be sealed following the splicing procedure as recommended by the manufacturer to provide a moisture proof environment for the splices. Care shall be taken at the cable entry points to ensure a tight and waterproof seal is made which will not leak upon aging.

The Contractor shall coil sufficient length of each cable in the communications/fibers vault that will allow the splice enclosure to be removed from the communications vault, and splices to be performed above ground in a vehicle specifically equipped for such work. Such coiled cable shall be located adjacent to the splice enclosure. Lengths of coiled cable shall be provided where shown in the Plans. The splice enclosure shall be bonded to the ground as per manufacturer's recommendations.

8-20.3(8)B4 Fiber Optic Cable Terminations

Fiber optic cable shall be terminated utilizing factory manufactured pigtailed with LC type connectors and UPC type polishing. Pigtails shall be fusion spliced to fiber optic cable.

8-20.3(8)B5 Fiber Optic Cable Patch Panels

Terminated fiber optic cable shall be installed in the signal controller cabinet utilizing patch panels. Patch panel(s) shall be Corning model Single-Panel Housing (SPH-01P) or approved equal. Panel(s) shall be wall mountable. Mounting location shall be as directed by the Engineer.

8-20.3(8)B6 Fiber Optic Cable Labeling

All fiber optic cable and patch cords shall be identified whenever entering or leaving a cabinet, vault, pull point/box or enclosure and at all terminals.

Permanent plastic marking tags fastened securely to the cables shall be used for identification.

Cable designation shall consistently conform to the overall scheme approved by the City to indicate location, circuit, device, cable number, terminal branch, position etc. Letters and numbers shall be used. Identification shall be made with a clear, machine produced, indelible marking.

All conduits shall be numbered and documented on the site plan as-built drawings.

Splice cases will be labeled at each entry point with nomenclature that includes the cable origination point, strand count, and destination. Fiber splice cases will be

labeled as "F-xxxx", where xxxx = the service cabinet location number based upon a City defined coordinate system.

All termination panels shall be labeled at each termination point for each fiber. Termination labels shall conform to the overall scheme approved by the City to indicate location, device and next access point. Identification shall be made with a clear, machine produced, indelible marking.

8-20.3(8)B7 Fiber Optic As-Built Records

The Contractor shall provide the Engineer with a cable route diagram indicating the actual cable route and "meter marks" for all intersections, directional change points in the cable mounting, and all termination points. The Contractor shall record these points during cable installation. The Contractor shall provide Cable system "as-built" drawings showing the exact cable route to the Engineer. Information such as the location of slack cable and its quantity shall also be recorded in the cable route diagram.

8-20.3(8)B8 Fiber Optic Cable Testing

The contractor is responsible for demonstrating the functionality of the installed optical fiber system through testing for compliance with the transmission requirements of this specification, the cable and hardware manufacturer's specifications, and prescribed industry standards and practices. The contractor shall, at its cost, provide suitable test equipment, instruments and labor for the purpose of tests.

The Contractor shall provide sufficient notice consistent with section 8-20.3(1) – Fiber Optic Service Outage Duration and Notification prior to the commencement of the first test. The Contractor shall submit with this notice a schedule of all tests covered by this notice.

8-20.3(8)B9 Type of Testing

The types or acceptance testing for optical fiber cable system certification are:

1. Attenuation testing
2. Optical Time Domain Reflectometer (OTDR) testing

8-20.3(8)B10 Attenuation Testing

Insertion loss testing shall be used to measure end-to-end attenuation on each new fiber installed between a field device and a fiber termination cabinet. Insertion loss testing shall be performed at the 1310 nanometer wavelength in both directions.

Prior to commencing testing, the Contractor shall submit the manufacturer and model number of the test equipment along with certification that it has been calibrated within 6 months of the proposed test dates.

The following information shall be documented for each fiber test measurement:

1. Wavelength
2. Fiber type
3. Cable, tube and fiber IDs

CITY OF FEDERAL WAY

**21ST AVE S & S 320TH STREET
SIGNALIZATION AND PEDESTRIAN
IMPROVEMENTS PROJECT
PROJECT #36225**

SP-122

CFW SPECIAL PROVISIONS VER. 2023.06

***** PLAN CENTER COPY *** Official bid documents, plan holder's list, and addenda (if applicable) are available on BXWA.com**

4. Near end and far end test locations
5. End-to-end attenuation
6. Date, time and operator

8-20.3(8)B11 Optical Time Domain Reflectometer (OTDR Testing)

An optical time domain reflectometer (OTDR) with recording capability shall be utilized to test the end-to-end transmission quality of each optical fiber. Quality tests shall consider both attenuation and discontinuities. The OTDR shall be equipped with 1310 nanometer and 1550 nanometer light sources for singlemode optical fibers.

The OTDR shall be capable of providing electronic and hard copy records of each test measurement.

The OTDR shall be equipped with sufficient internal masking to allow the entire cable section to be tested. This may be achieved by using an optical fiber pigtail of sufficient length to display the required cable section or by using an ODTR with sufficient normalization to display the required cable section.

Prior to commencing testing, the Contractor shall submit the manufacturer and model number of the OTDR test unit along with certification that it has been calibrated within the 6 months of the proposed test dates.

Each new mainline and lateral fiber shall be tested in both directions at the 1310 and 1550 nanometer wavelengths. Existing mainline and lateral fibers that are spliced to or re-spliced as part of this contract shall also be tested in both directions and at both wavelengths.

The following information shall be documented for each fiber test measurement:

1. X-Y scatter plot for fiber length
2. Wavelength
3. Refraction index
4. Fiber type
5. Averaging time
6. Pulse width
7. Cable and fiber IDs
8. Near end and far end test locations
9. Date, time, and operator
10. Event table that includes: event ID, type, location, loss and reflection

8-20.3(8)B12 Fiber Optic Cable Testing Documentation

The Contractor shall submit on hard copy and one electronic copy of the fiber test results to the Engineer for approval. The Contractor shall take corrective actions on portions of the fiber installation determined to be out of compliance with these specifications.

Upon acceptance of the cable installation and test results, the Contractor shall submit three (3) hard copies and one electronic copy of the fiber test results to the Engineer.

CITY OF FEDERAL WAY

**21ST AVE S & S 320TH STREET
SIGNALIZATION AND PEDESTRIAN
IMPROVEMENTS PROJECT
PROJECT #36225**

SP-123

CFW SPECIAL PROVISIONS VER. 2023.06

***** PLAN CENTER COPY *** Official bid documents, plan holder's list, and addenda (if applicable) are available on BXWA.com**

Hard copy submittals shall be bound in 3-ring binders. The electronic submittal shall be on a compact disk and include one licensed copy of the applicable OTDR reader program.

The following information shall be included in each test result submittal:

1. Contract number, contract name, Contractor name and address.
2. Dates of cable manufacture, installation and testing.
3. Cable specifications.
4. Locations of all splices.
5. OTDR test results.
6. Attenuation test results.

8-20.3(8)B13 Racking in Fiber Vaults

The Contractor shall rack the cable in vertical figure eight loops, which shall permit pulling slack from the vault without introducing twist to the cable. The splice closures shall also be racked.

Cables shall be racked and secured with nylon ties. Nylon ties shall not be over-tightened. Identification or warning tags shall be securely attached to the cables in at least two locations in each fiber vault.

All coiled cable shall be protected to prevent damage to the cable and fibers. Racking shall include securing cables to brackets (racking hardware) that extend from the sidewalls of the fiber vault.

8-20.3(8)B14 Documentation

Documentation for each system element shall consist of the manufacturer's name and model number, serial number when available, materials and operating specifications, wiring schematic and parts list, owners manuals, factory service manuals, and procedures for factory testing and system acceptance testing specified elsewhere herein. The Contractor shall submit three (3) copies of the documentation specified above prior to installation of the cable or components described in the submittal. In addition, the Contractor shall submit three (3) copies of an overall system wiring schematic and termination chart for the installed elements (operation and maintenance manuals). All documentation for each individual element shall be neatly bound in a way for the information is secured together and is totally legible without removing the information from the binding. This documentation shall be in addition to any other data, shop drawings, etc. required to be submitted as specified in these Special Provisions.

8-20.3(8)B15 Warranty

The Data Distribution and Transmission Systems and components shall be provided with a one-year minimum, on-site parts and labor warranty from the date that the system successfully completed testing. This quality assurance shall cover each piece of equipment and shall be provided by the manufacturer or agent of said equipment.

8-20.3(8)C Video, Voice, and Data Distribution and Transmission System ***(January 26, 2012 CFW GSP)***

CITY OF FEDERAL WAY

21ST AVE S & S 320TH STREET
SIGNALIZATION AND PEDESTRIAN
IMPROVEMENTS PROJECT
PROJECT #36225

SP-124

CFW SPECIAL PROVISIONS VER. 2023.06

*** PLAN CENTER COPY *** Official bid documents, plan holder's list, and addenda (if applicable) are available on BXWA.com

Section 8-20.3(8)C and all its subsections are new sections:

All wiring, cable, and cords associated with this equipment shall be neatly dressed and secured to the rack frames or cable trays by nylon ties.

8-20.3(8)C1 Documentation

Documentation for each system element shall consist of the manufacturer's name and model number, serial number when available, materials and operating specifications, wiring schematic and parts list, owner's manuals, factory service manuals, and procedures for factory testing and system acceptance testing specified elsewhere herein. The Contractor shall submit three (3) copies of the documentation specified above prior to installation of the cable or components described in the submittal. In addition, the Contractor shall submit three (3) copies of an overall system wiring schematic and termination chart for the installed elements (operation and maintenance manuals). All documentation for each individual element shall be neatly bound in a way for the information is secured together and is totally legible without removing the information from the binding. This documentation shall be in addition to any other data, shop drawings, etc. required to be submitted as specified in these Special Provisions.

8-20.3(8)C2 Warranty

The Data Distribution and Transmission Systems and components shall be provided with a one-year, on-site parts and labor warranty from the date that the system successfully completed testing. This quality assurance shall cover each piece of equipment and shall be provided by the manufacturer or agent of said equipment.

(March 13, 2012 CFW GSP)

Section 8-20.3(9) is supplemented with the following:

Contractor shall provide and install bonding and grounding wires as described in Standard Specifications and the National Electric Code for any new metallic junction boxes and any modified existing junction boxes. For the purposes of this section, a box shall be considered "modified" if new current-carrying conductors are installed, including low-voltage conductors.

At points where shields of shielded conductors are grounded, the shields shall be neatly wired and terminated on suitable grounding lugs.

Junction box lids and frames shall be grounded in accordance with Department of Labor and Industries standards, and shall be grounded so that the ground will not break when the lid is removed and laid on the ground next to the junction box.

All conduits which are not galvanized steel shall have bonding wires between junction boxes.

Ground rods shall be copper clad steel, 3/4-inch in diameter by 10-feet long, connections shall be made with termite welds.

At points where wiring shields of shielded conductors are grounded, the shields shall be neatly wired and terminated on suitable grounding lugs.

CITY OF FEDERAL WAY

**21ST AVE S & S 320TH STREET
SIGNALIZATION AND PEDESTRIAN
IMPROVEMENTS PROJECT
PROJECT #36225**

SP-125

CFW SPECIAL PROVISIONS VER. 2023.06

***** PLAN CENTER COPY *** Official bid documents, plan holder's list, and addenda (if applicable) are available on BXWA.com**

(October 23, 2014 CFW GSP)

Section 8-20.3(9) is supplemented with the following:

In addition to the service grounds provided at the service cabinet each Type II, III, IV, or V signal standard shall have a supplemental ground installed.

8-20.3(10) Services, Transformer, Intelligent Transportation System Cabinet

(March 13, 2012 CFW GSP)

Section 8-20.3(10) is supplemented with the following:

The Contractor shall apply for an electrical service connection with Puget Sound Energy or Tacoma Public Utilities as applicable and make arrangements for a new electrical service connection.

The Engineer will approve Electrical Service Installations. The Contractor shall request the City of Federal Way Building Division to perform required inspections for service approval.

Electrical service is detailed in the Plans. The Contractor shall notify the City of Federal Way inspector when the service is ready for connection.

A two-circuit electrical service shall be used at 240/120 volts, 60 Hz AC. The underground electrical service shall be brought to the load center in minimum 2-inch conduit. Wire sizes and conduit terminations between the load center and the connection location shall meet the requirements of PSE or Tacoma Public Utilities as applicable. The service shall be split in the load center into a 120-volt circuit for the signals and 240 volt for the illumination. When the service is to be provided from an overhead source, the Contractor shall provide conduit from the electrical service to ten feet up the power pole from which service is provided. Stand-off brackets 14 inches long shall be installed on the pole every ten feet. In addition, the Contractor shall provide service conductors from the electrical service to the top of the conduit on the power pole with 30 feet of service wire coiled at top and provide the local electrical utility with 30 feet of 2-inch conduit to make the connection.

Electrical service cabinet will be painted inside with white polyurethane or polyester urethane power coat in accordance with Section 6-07. Outside will be bare aluminum finish.

The twist lock photocell shall be mounted on top of the luminaire closest to the electrical service.

All circuit breakers shall be clearly marked or labeled.

8-20.3(11) Testing

(April 12, 2018 CFW GSP)

Section 8-20.3(11) is supplemented with the following:

After power switch over, the signal system shall be put into operation by King County personnel. The Contractor shall be present during the turn-on with

CITY OF FEDERAL WAY

**21ST AVE S & S 320TH STREET
SIGNALIZATION AND PEDESTRIAN
IMPROVEMENTS PROJECT
PROJECT #36225**

SP-126

CFW SPECIAL PROVISIONS VER. 2023.06

***** PLAN CENTER COPY *** Official bid documents, plan holder's list, and addenda (if applicable) are available on BXWA.com**

adequate equipment to repair any deficiencies in operation. The Contractor shall notify King County five working days in advance of power switch over.

8-20.3(14)A Signal Controllers
(December 18, 2009 CFW GSP)

Section 8-20.3(14) is supplemented with the following:

The new signal controller and cabinet shall conform to all of the sections and requirements within and under the Sections and Sub Sections of 9-29.13 Traffic Signal Controllers within the Standard Specifications and these Special Provisions.

Signal controller and cabinet shall be tested by King County at their shop located at 155 Monroe Avenue NE in Renton, Washington. The contractor shall deliver the controller and cabinet to the shop and shall pick up the units at the end of the test period, deliver to the job site, and install.

8-20.3(14)B Signal Heads
(March 22, 2023 CFW GSP)

The first paragraph is deleted and replaced with the following:

If the Engineer orders advance installation, the signal heads shall be covered to clearly indicate the signal is not in operation. The signal head covering material shall be of sufficient size to entirely cover the display. The covering shall extend over all edges of the signal housing and shall be securely fastened at the back.

Signal heads shall be installed with back plates. A two (2) inch wide strip of Type IX yellow retro reflective sheeting shall be applied to the outside border of the back plates in accordance with the manufacturer's recommendations. The application surface of the back plate shall be cleaned, degreased

Section 8-20.3(14)B is supplemented with the following:

Alignment of vehicular and pedestrian signal heads shall be approved by the Engineer prior to system turn-on.

All new vehicular and pedestrian signal heads shall be covered (sacked) completely including backplates with a 6 mil black polyethylene sheeting until placed into initial operation. The fitted covers shall use adjustable straps. The fitted covers shall have a one-inch hole for each signal display to flash out indications.

The type of mounting hardware specified for the mast arm mounted vehicle signals may require modification at the time of installation to accommodate as built conditions. After the pole assembly has been installed and leveled, the Contractor shall measure the distance between each mounting point on the arm and the roadway. A type of mounting bracket different from that specified in the Plans shall be provided and installed by the Contractor if necessary to achieve the following criteria:

1. Red indications shall be in as straight a line as possible.
2. The bottom of the housing shall be between 16.5 feet and 19.0 feet above the pavement.

CITY OF FEDERAL WAY

**21ST AVE S & S 320TH STREET
SIGNALIZATION AND PEDESTRIAN
IMPROVEMENTS PROJECT
PROJECT #36225**

SP-127

CFW SPECIAL PROVISIONS VER. 2023.06

*** PLAN CENTER COPY *** Official bid documents, plan holder's list, and addenda (if applicable) are available on [BXWA.com](https://www.bxwa.com)

8-20.3(14)E Signal Standards
(December 18, 2009 CFW GSP)

Section 8-20.3(14)E is supplemented with the following:

Traffic signal standards shall be furnished and installed in accordance with the methods and materials noted in the applicable Standard Plans, pre-approved plans, or special design plans.

After delivering the poles or arms to the job site and before they are installed, they shall be stored in a place that will not inconvenience the public. All poles and arms shall be installed in compliance with Washington State Utility and Electrical Codes.

Terminal cabinet(s) shall be installed on all Type II and Type III signal poles or where designated on the wiring diagrams in the Plans in accordance with the material requirements of Section 9-29.25 of the Standard Specifications. Terminal cabinets shall be installed at a height not to impede pedestrians.

8-20.3(14)F Opticom Detectors
(December 18, 2009 CFW GSP)

Section 8-20.3(14)F is a new section:

Opticom detectors shall be installed in a drilled and tapped hole in the top of the mast arm unless otherwise shown in the Plans. They shall be tightly fitted to point in the direction shown in the plan view. Lead-in cable back to the controller shall be 6TT detector 138 cable, or equivalent, and shall have no splices. All lead-in cables shall be connected to terminals in the controller cabinet as shown in the wiring diagram. The shields shall be grounded to the grounding bar.

8-20.3(14)G Video Camera Detectors
(December 18, 2009 CFW GSP)

Section 8-20.3(14)G is a new section:

The video camera shall be installed consistent with the manufacturer recommendations. Controller cabinet equipment shall be installed in the cabinet when cabinet testing is performed.

8-20.3(17) "As Built" Plans
(December 18, 2009 CFW GSP)

Section 8-21.3(17) is deleted and replaced with the following:

Upon completion of the project, the Contractor shall furnish an "as-built" drawing of the intersection showing all signal heads, pole locations, detectors, junction boxes, illumination system showing luminaire locations, miscellaneous equipment, conductors, cable wires up to the signal controller cabinet, and with a special symbol identifying those items that have been changed from the original contract drawings. All items shall be located to within one foot (1') horizontally and six inches (6") vertically above or below the finished surface grade.

8-20.3(18)Removal of Existing Signal Equipment
(March 22, 2023 CFW GSP)

Section 8-21.3(18) is a new section:

Where noted in the Plans, existing signal, illumination, Safe City Cameras and relate equipment, and interconnect equipment shall be removed by the Contractor.

The Engineer shall decide the ownership of all salvaged signal, illumination, Safe City Cameras and related equipment, and interconnect equipment materials. All salvaged signal materials not directed by the Engineer to remain property of the City shall be the property of the Contractor, except that any existing controllers and UPS cabinets and all contents shall be delivered to the King County Signal Shop at 155 Monroe Avenue NE, Renton, Washington 98056. All other material removed shall become the property of the Contractor and shall be disposed of off-site at a legal disposal site.

All pole foundations and anchor bolts shall be removed to 6 feet below new subgrade, and the resulting hole shall be backfilled with compacted gravel borrow meeting the requirements of Section 9-03.14(1), unless the Engineer has approved the use of native material.

Where junction boxes are removed, the conduit and wire shall also be removed to the bottom of the trench and the resulting hole backfilled with gravel borrow meeting the requirements of Section 9-03.14(1), unless the Engineer has approved the use of native material.

Removals associated with the electrical system shall not be stockpiled within the jobsite without the Engineer's approval.

8-20.4 Measurement

(April 12, 2018 CFW GSP)

Section 8-20.4 is replaced with the following:

"Traffic Signal System, Complete" shall be measured per lump sum.

"Illumination System, Complete", shall be measured per lump sum.

"Decorative Illumination System, Complete" shall be measured per lump sum.

"Festival Outlet System, Complete" shall be measured per lump sum.

"Interconnect System, Complete" shall be measured per lump sum.

8-20.5 Payment

(December 1, 2021 CFW GSP)

Section 8-20.5 is deleted and replaced with the following:

Payment will be made in accordance with the following:

"Traffic Signal System, Complete", per lump sum.

"Illumination System, Complete", per lump sum.

"Decorative Illumination System, Complete", per lump sum.

"Festival Outlet System, Complete", per lump sum.

"Interconnect System, Complete", per lump sum.

The lump sum price for "Traffic Signal System, Complete" shall be full pay for furnishing all labor, equipment, materials and supplies necessary to complete the work as specified. All items and labor necessary to supply, install, and test the system including, but not limited to, conduit, junction boxes, service circuit breaker and connections, battery backup system, signal/service/battery backup system foundation(s), vehicular and pedestrian signal heads, pedestrian pushbuttons, emergency vehicle preemption, temporary and/or permanent vehicle detection system(s), connections with existing conduit and junction boxes, mast arm mounted traffic signs, restoring facilities destroyed or damaged during

CITY OF FEDERAL WAY

**21ST AVE S & S 320TH STREET
SIGNALIZATION AND PEDESTRIAN
IMPROVEMENTS PROJECT
PROJECT #36225**

SP-129

CFW SPECIAL PROVISIONS VER. 2023.06

***** PLAN CENTER COPY *** Official bid documents, plan holder's list, and addenda (if applicable) are available on BXWA.com**

construction, removing and salvaging existing signal equipment, the installation of a temporary signal system as needed, relocation of temporary signal equipment (vehicle heads, pre-emption, pedestrian heads, pedestrian push buttons, video detection) to accommodate construction phasing throughout the project, installation of non-slip MMA coating on new or existing lids located within accessible surfaces, and all other components necessary to make a complete traffic signal system shall be included within the lump sum measurement. The lump sum bid price shall include all costs associated with the construction of the cement concrete pad and pedestal for the controller and service cabinets as well as for the cement concrete pads around signal poles. All costs for installing signing on signal mast arms or temporary signal installations shall be incidental to the bid item(s) in this section and no additional compensation will be made. Luminaires and luminaire arms positioned on signal poles will be considered a part of the traffic signal system lump sum measurement. Removal of an existing signal system or existing signal components shall be included within the lump sum measurement. After construction is complete, it is Contractor's responsibility to adjust, relocate, and reposition all traffic signal heads to their final position as shown on the Contract Documents, and shall be considered incidental to the lump sum measurement.

The lump sum price for "Illumination System, Complete" shall be full pay for furnishing all labor, equipment, materials and supplies necessary to complete the work as specified. The lump sum price shall include all costs associated with connecting the illumination system to the service cabinet and for making modifications to the existing systems as noted. All items and labor necessary to supply, install, and test the conduit, junction boxes, service circuit breaker and connections, the photocell, electrical service and service cabinet electrical connections, connections with existing conduit and junction boxes, restoring facilities destroyed or damaged during construction, salvaging existing materials, installation of non-slip MMA coating on new or existing lids located within accessible surfaces, and all other components necessary to make a complete system shall be included within the lump sum measurement.

The lump sum price for "Decorative Illumination System, Complete" shall be full pay for furnishing all labor, equipment, materials and supplies necessary to complete the work as specified. The lump sum price shall include all costs associated with connecting the decorative illumination system to the service cabinet and for making modifications to the existing systems as necessary. All items and labor necessary to supply, install, and test the poles, conduit, junction boxes, service circuit breaker and connections, electrical connections, connections with existing conduit and junction boxes, installation of non-slip MMA coating on new or existing lids located within accessible surfaces, and all other components necessary to make a complete system shall be included within the lump sum measurement.

The lump sum price for "Festival Outlet System, Complete" shall be full pay for furnishing all labor, equipment, materials and supplies necessary to complete the work as specified. The lump sum price shall include all costs associated with connecting the festival outlet system to the service cabinet and for making modifications to the existing systems as necessary. All items and labor necessary to supply, install, and test the conduit, junction boxes, electrical connections, connections with existing conduit and junction boxes, GFI outlets, boxes and covers, restoring facilities destroyed or damaged during construction,

CITY OF FEDERAL WAY

**21ST AVE S & S 320TH STREET
SIGNALIZATION AND PEDESTRIAN
IMPROVEMENTS PROJECT
PROJECT #36225**

SP-130

CFW SPECIAL PROVISIONS VER. 2023.06

***** PLAN CENTER COPY *** Official bid documents, plan holder's list, and addenda (if applicable) are available on BXWA.com**

salvaging existing materials, installation of non-slip MMA coating on new or existing lids located within accessible surfaces, and all other components necessary to make a complete system shall be included within the lump sum measurement.

The lump sum price for "Interconnect System, Complete" shall be full pay for furnishing all labor, equipment, materials and supplies necessary to complete the work as specified. The lump sum price shall include all costs associated with connecting the interconnect system to the signal cabinet and for making modifications to the existing systems as necessary. All items and labor necessary to supply, install, and test the conduit, single-mode fiber optic cable, junction boxes, connections with signal controllers, connections with existing conduit, junction boxes and fiber optic vaults, connections with existing interconnect systems, pull rope, plugs, restoring facilities destroyed or damaged during construction, salvaging existing materials, installation of non-slip MMA coating on new or existing lids located within accessible surfaces, and all other components necessary to make a complete interconnect communication system as well as a system ready for the future installation of fiber optic cable shall be included within the lump sum measurement. Interconnect cable installed in existing conduit will be included in the lump sum measurement.

Sawcutting for trench, sawcutting for "T-cut" trench restoration, pavement removal, excavation, trenching, bedding and backfill materials, backfilling of trenches, pavement restoration of trenches and conduit/junction box installations shall be incidental to the bid items included in this section and no additional compensation will be made.

Coordination of service connections with Puget Sound Energy and any necessary permits and fees associated with the service connections shall be considered incidental to the bid items included in this section and no additional compensation will be made.

Coordination with communication connections with Comcast, Qwest, or other communication provider affected by this project, and any necessary permits and fees associated with the communications connections shall be considered incidental to the bid items included in this section and no additional compensation will be made.

All costs for installing junction boxes and conduit containing traffic signal system, illumination system, decorative illumination system, festival outlet system and/or interconnect system wiring shall be incidental to the bid item(s) of this section and no additional compensation will be made.

All costs for painting shall be incidental and included in the bid items included in this section and no additional compensation will be made.

Adjustment of junction boxes shall be incidental and included in the bid items included in this section and no additional compensation will be made.

Restoration of facilities destroyed or damaged during construction shall be considered incidental to the bid items included in this section and no additional compensation will be made.

CITY OF FEDERAL WAY

**21ST AVE S & S 320TH STREET
SIGNALIZATION AND PEDESTRIAN
IMPROVEMENTS PROJECT
PROJECT #36225**

SP-131

CFW SPECIAL PROVISIONS VER. 2023.06

***** PLAN CENTER COPY *** Official bid documents, plan holder's list, and addenda (if applicable) are available on [BXWA.com](https://www.bxwa.com)**

(*****)

Section 8-20.5 is supplemented with the following:
“Adjust Junction Box to Grade”, per each.

Section 8-20.5 is supplemented with the following:

(***PROJECT-SPECIFIC SPECIAL PROVISION***)

All costs for directional boring for installation of traffic signal, illumination, decorative illumination, or interconnect shall be considered incidental to the bid item(s) of this section and no additional payment will be made.

SECTION 8-21 PERMANENT SIGNING

8-21.1 Description

(March 22, 2023 CFW GSP)

Section 8-21.1 is deleted and replaced with the following:

This work shall consist of furnishing and installing permanent signing, sign removal, and sign relocation, in accordance with the Plans, these Specifications, the Standard Plans, MUTCD, and the City of Federal Way Standard Details at the locations shown in the Plans or where designated by the Engineer. Signs to be removed as shown in the Plans, shall be returned to the Owner.

Colors of all permanent signs shall be submitted to the City for approval prior to installation in the field. Installed signs that do not have color approved by the City may be required to be removed and replaced in an acceptable color at the Contractor’s expense.

8-21.4 Measurement

(April 12, 2018 CFW GSP)

Section 8-21.4 is deleted and replaced with the following:

“Permanent signing” is measured on a lump sum basis

8-21.5 Payment

(April 12, 2018 CFW GSP)

Section 8-21.5 is deleted and replaced with the following:

The lump sum price for “Permanent Signing” shall include all labor, materials, tools, and equipment necessary to furnish and install permanent signing, sign removal, and sign relocation. Sign covering shall be incidental and shall not be measured.

All costs for furnishing and installing signs on traffic signal mast arms poles shall be included in the lump sum price for “Traffic Signal System – Complete”.

SECTION 8-22 PAVEMENT MARKING

8-22.1 Description

(November 2, 2020 CFW GSP)

Section 8-22.1 is supplemented with the following:

Pavement markings shall conform to City of Federal Way Standard Details. Profiled and plastic lines shall conform to the pattern as shown on WSDOT Standard Plan M-20.20.

CITY OF FEDERAL WAY

**21ST AVE S & S 320TH STREET
SIGNALIZATION AND PEDESTRIAN
IMPROVEMENTS PROJECT
PROJECT #36225**

SP-132

8-22.2 Materials

(August 27, 2021 CFW GSP)

Section 8-22.2 Sentence #3 is deleted and replaced with the following:

Glass beads for Type A plastic shall be as recommended by the manufacturer.

Section 8-22.2 is supplemented with the following:

Glass beads for Type D plastic and Reflective Elements shall be per Section 9-34.4.

8-22.3 Construction Requirements

(March 22, 2023 CFW GSP)

Section 8-22.3 is supplemented with the following:

Permanent pavement markings shall be installed within 30 calendar days after paving. If a project contains paving on multiple streets (i.e. schedules of work), this requirement applies to the paving date for each street / schedule individually.

8-22.3(6) Removal of Pavement Markings

(March 22, 2023 CFW GSP)

Section 8-22.3(6) is supplemented with the following:

As indicated in the plans, the Contractor shall remove existing pavement markings that may consist of paint, plastic and raised pavement markings.

8-22.4 Measurement

(December 16, 2022 CFW GSP)

Paragraphs 12 and 13 of Section 8-22.4 are replaced with the following:

Measurement for the removal of all pavement markings will be per lump sum.

(March 22, 2023 CFW GSP)

Section 8-22.4 is supplemented with the following:

Raised Pavement Markers are incidental to Pavement Markings. No separate measurement or payment will be made.

8-22.5 Payment

(December 16, 2022 CFW GSP)

Section 8-22.5 is modified as follows:

The following bid items are deleted:

- “Removing Paint Line”, per linear foot.
- “Removing Plastic Line”, per linear foot.
- “Removing Painted Crosswalk Line”, per square foot.
- “Removing Plastic Crosswalk Line”, per square foot.
- “Removing Painted Traffic Marking”, per each.
- “Removing Plastic Traffic Marking”, per each.

The following is a new bid item:

- “Removing Pavement Markings”, lump sum.

8-23 TEMPORARY PAVEMENT MARKINGS

CITY OF FEDERAL WAY

21ST AVE S & S 320TH STREET
SIGNALIZATION AND PEDESTRIAN
IMPROVEMENTS PROJECT
PROJECT #36225

SP-133

8-23.1 Description

(March 22, 2023 CFW GSP)

Section 8-23.1 is supplemented with the following:

Temporary pavement markings shall be installed and maintained by the Contractor prior to traffic being released onto public streets when the installation of permanent pavement markings is not yet completed. All pavement markings including lines, symbols, and raised pavement markers shown on the plans and details shall be provided as temporary pavement markings until such time that permanent pavement markings are installed. Temporary pavement markings shall generally follow the alignment for the permanent pavement markings.

8-23.2 Low VOC Waterborne Paint

(March 22, 2023 CFW GSP)

Section 8-23.2 is replaced with the following:

The City of Federal Way does not allow Low VOC Waterborne Paint for temporary or permanent pavement markings.

8-23.3(4)A Temporary Pavement Markings – Short Duration

(March 22, 2023 CFW GSP)

Paragraph 2 of Section 8-23.3(4)A is modified as follows:

Temporary Center Line (Double Yellow Center Line) – Two SOLID lines used to delineate adjacent lanes of traffic moving in opposite directions. Temporary raised pavement markings should be installed on both sides of the yellow lines at 40-foot intervals.

Temporary Center Line (Skip Center Line) – A BROKEN line used to delineate adjacent lanes of traffic moving in opposite directions. The broken pattern shall be based on a 10-foot unit, consisting of a 1-foot line with a 9-foot gap.

8-23.4 Measurement

(March 22, 2023 CFW GSP)

Section 8-23.4 is supplemented with the following:

Temporary Flexible Raised Pavement Markers are incidental to Temporary Pavement Markings. No separate measurement or payment will be made.

Traffic control (Flaggers, Traffic Control Supervisor, Other Traffic Control, etc.) for the initial installation of Temporary Pavement Markings shall be measured and paid per the respective Traffic Control Bid Items. Traffic control associated with the subsequent maintenance of Temporary Pavement Markings shall be incidental to the temporary pavement making bid items and no additional payment will be made.

8-30 POTHOLING AND RESOLUTION OF UTILITY CONFLICTS

(April 12, 2018 CFW GSP)

Section 8-30 and its subsections are new sections as follows:

8-30.1 Description

(April 12, 2018 CFW GSP)

Section 8-30.1 is a new section:

CITY OF FEDERAL WAY

21ST AVE S & S 320TH STREET
SIGNALIZATION AND PEDESTRIAN
IMPROVEMENTS PROJECT
PROJECT #36225

SP-134

This work involves the identification and resolution of utility conflicts not identified in the plans between proposed improvements and existing utilities. The City will pay these costs by force account if the work proves to be acceptable and the Contractor had performed the work with the authority of and due notice to the Engineer.

8-30.3 Construction Requirements

(April 12, 2018 CFW GSP)

Section 8-30.3 is a new section:

The City may direct the Contractor to pothole existing utilities to verify the field location and depth. Potholing shall include excavation and backfilling of the existing utility, identification of the pipe or line size, material type and condition and the survey work to locate the facility horizontally and vertically. Survey information to be obtained shall include station and offset to center of utility and elevation at top of utility. Stations, offsets and elevations shall be to the nearest 0.1 foot unless greater accuracy is required. Potholes shall be backfilled with CSTC compacted to 95%, or with CDF, as directed by the Engineer. In areas subject to public traffic, the HMA patch shall match the depth of the surrounding pavement.

In the event that a conflict arises between the proposed improvements and an existing utility, the Resolution of Utility Conflicts item will compensate the Contractor for standby time and additional work in the following manner:

1. Standby time resulting from existing utility conflicts. Standby time is defined as time the Contractor is unable to proceed with progression of a specific work item (i.e. storm drainage, underground utility installation etc.) due to conflicts with existing facilities. However, payment for standby time shall be limited to:
 - a. For each agreed upon conflict, a maximum of four (4) hours of standby time will be paid for actual delay of labor and equipment due to a utility conflict. The Contractor shall be responsible to adjust his work schedule and/or reassign his work forces and equipment to other areas of work to minimize standby time.
 - b. If the conflict is resolved within one (1) hour of notification to the Engineer, no standby time will be paid.
2. Additional work required to resolve utility conflicts will be paid for at the bid unit prices for the associated work. Work that can be measured and paid for at the unit contract prices shall not be identified as force account work. This work includes but is not limited to:
 - a. Storm drainage manhole, pipe, vault, and conduit realignments of line and/or grade for the storm drain and undergrounding of overhead utilities, to avoid existing utility conflicts.
 - b. Additional storm drainage manholes, pipe, vaults, and conduit required by a change in alignment, and/or grade, not exceeding the limits set in section 1-04.4 of the Standard Specifications.

8-30.4 Measurement

(April 12, 2018 CFW GSP)

Section 8-30.4 is a new section:

"Potholing", will be measured for force account per Section 1-09.6.

"Resolution of Utility Conflicts" will be measured for force account per Section 1-09.6.

CITY OF FEDERAL WAY

**21ST AVE S & S 320TH STREET
SIGNALIZATION AND PEDESTRIAN
IMPROVEMENTS PROJECT
PROJECT #36225**

SP-135

8-30.5 Payment

(April 12, 2018 CFW GSP)

Section 8-30.5 is a new section:

"Potholing", will be paid by force account.

"Resolution of Utility Conflicts", will be paid by force account

To provide a common proposal for all bidders, the City has estimated the amount for "Resolution of Utility Conflicts" and "Potholing" and entered the amounts in the proposal to become a part of the total bid by the Contractor.

Utility conflicts due to the Contractor's actions or operations shall be resolved by the Contractor at no expense to the Contracting Agency.

8-31 Curb Wall

New Section

(*****)

8-31.1 Description

Section 8-31 describes constructing Portland cement concrete curb walls at locations and in conformity with the lines and grades, shown on the Drawings.

8-31.2 Materials

Materials must comply with the requirements of the following Sections:

Cement Concrete	9-01
Mineral Aggregate	9-03
Reinforcing Steel	9-07

8-31.3 Construction Requirements

8-31.3(1) General

Where shown on the Drawings, the Contractor must construct curb walls as shown on the.

After removal of forms, all lips and edgings must be removed. Bolts or concrete ties must be removed and the holes filled with 1:2 mortar and floated to an even uniform surface. If in the opinion of the Engineer an acceptable surface has been obtained, no further finishing must be done. If, however, the surface is unacceptable, these surfaces must be thoroughly washed with water and a 1:1 mortar applied with brush and completely worked into the small air holes and other crevices. After initial set, the surface must be rubbed with a damp sack.

8-31.3(2) Curb Wall

Curb wall must be constructed as indicated on the plans.

CITY OF FEDERAL WAY

**21ST AVE S & S 320TH STREET
SIGNALIZATION AND PEDESTRIAN
IMPROVEMENTS PROJECT
PROJECT #36225**

SP-136

CFW SPECIAL PROVISIONS VER. 2023.06

*** PLAN CENTER COPY *** Official bid documents, plan holder's list, and addenda (if applicable) are available on BXWA.com

8-31.4 Measurement

Measurement for curb wall will be per cubic yard of concrete. The vertical limits for measurement are from the bottom of the bottom of the foundation to the top of the wall. The horizontal limits for measurement are from the end of the wall to the end of the wall.

8-31.5 Payment

“Curb Wall”, per cubic yard.

The bid item price for “Curb Wall” (including reinforcement steel extending into pavement slab) must include all costs for the work required to construct the wall as shown in the plans. Payment for excavation, disposal of materials, geotextile, and for reinforcing steel for curb wall is considered included in the bid item price.

END OF DIVISION 8

CITY OF FEDERAL WAY

**21ST AVE S & S 320TH STREET
SIGNALIZATION AND PEDESTRIAN
IMPROVEMENTS PROJECT
PROJECT #36225**

SP-137

CFW SPECIAL PROVISIONS VER. 2023.06

***** PLAN CENTER COPY *** Official bid documents, plan holder's list, and addenda (if applicable) are available on BXWA.com**

DIVISION 9 MATERIALS

9-01 CONCRETE

9-01.2 Specifications

9-01.2(1)B Blended Hydraulic Cement

(December 16, 2022 CFW GSP)

Section 9-01.2(1)B is modified with the following:

Type 1L cement is only allowed for use within the City of Federal Way subject to the conditions listed below:

	Class 3000 Type 1L	Class 4000 Type 1L	Class 4000 Type 1L with crystalline waterproofing and corrosion protection admixture ¹	Class 5000 Type 1L
Pre-cast Foundations (luminaires, signals, RRFBs, etc.)	X	X	X	X
Cast-in-Place Foundations (luminaires, signals, RRFBs, etc.)		X	X	X
Pre-cast or cast-in-place catch basins and manholes		X	X	X
Roads, curbs, curb & gutters, roundabouts & aprons, sidewalks, ADA ramps, driveway approaches			X	X
Other exposed surfaces (retaining walls, junction box aprons, cabinet bases, barriers, etc.)			X	X

¹ Crystalline Waterproofing admixtures (Penetron or approved equal) shall meet the following specification: ASTM C494, Type S, hydrophilic, crystalline permeability-reducing admixture for hydrostatic conditions (PRAH) shall form insoluble crystals throughout the concrete matrix, self-healing and sealing all pores, capillaries and cracks up to 0.5mm (1/51 inch). The crystalline waterproofing admixture shall include a colored tracer material so that it is visible when included in the concrete mix.

For all Type 1L concrete mixes, the City will not accept any maleated rosin (i.e. MasterAir AE90) as a supplied air entrainment and waterproofing admixture or any wax-based curing compounds.

9-03 AGGREGATES

9-03.12 Gravel Backfill

CITY OF FEDERAL WAY

21ST AVE S & S 320TH STREET
SIGNALIZATION AND PEDESTRIAN
IMPROVEMENTS PROJECT
PROJECT #36225

SP-138

9-03.12(6) Pit Run Sand
(April 12, 2018 CFW GSP)

Section 9-03.12(6) is a new section:

<u>Sieve Size</u>	<u>Percent Passing</u>
3/8" square	100
U.S. No. 4	90
Sand Equivalent	30 minimum

9-03.14(3) Common Borrow
(April 12, 2018 CFW GSP)

Section 9-03.14(3) is modified with the following requirements:

Material from on-site excavations meeting the requirements for Common Borrow shall be used to the extent practicable. Material for common borrow shall consist of granular soil and/or aggregate which is free of trash, wood, debris, and other deleterious material.

Common Borrow material shall be at the proper moisture content for compaction. This material is generally moisture sensitive. The natural moisture content shall range from not more than 1 percent wet of optimum to not more than 3 percent dry of optimum as determined in accordance with Section 2-03.3(14)D. The material shall not pump or yield under the weight of compaction equipment and construction traffic. The Contractor is responsible for protecting the material from excess moisture wherever/whenever possible. To the extent practicable, this material should be handled only during non-rainy periods and should be removed, hauled, placed, and compacted into final embankments without intermediate handling or stockpiling. Surfaces should be graded and sloped to drain and should not be left uncompacted.

Common Borrow shall meet the following gradation limits:

Sieve Size	Percent Passing (by weight)
6" square ¹	100
4" square	90 – 100
2" square	75 - 100
U.S. No. 4	50 - 80
U.S. No. 40	50 max.
U.S. No 200	25 max.

¹ For geosynthetic reinforced walls or slopes, 100percent passing 1¼-inch square sieve and 90 to 100 percent passing the 1-inch square sieve.

Common Borrow shall contain sufficient fines for compaction and to bind the compacted soil mass together to form a stable surface when heavy construction equipment is operated on its surface.

9-05 DRAINAGE STRUCTURES AND CULVERTS

9-05.15 Metal Castings

9-05.15(4) Heavy Duty Hinged Style Ductile Iron Frame and Cover

CITY OF FEDERAL WAY

21ST AVE S & S 320TH STREET
SIGNALIZATION AND PEDESTRIAN
IMPROVEMENTS PROJECT
PROJECT #36225

SP-139

(December 2, 2019 CFW GSP)

Section 9-05.15(4) is a new section:

Heavy-Duty hinged style ductile iron frame and covers shall meet the requirements for metal castings found in Section 9-05.15. The covers shall be hinged and incorporate a 90-degree blocking system to prevent accidental closure. The cover shall be operable by one person using standard tools and shall allow for the cover to open to 120-degrees where it can either remain open in a secure position or be removed if needed. The cover pick slot shall provide a solid point of removal for most removal tools and be designed to eliminate surface water inflow. The covers shall be lockable with a cam lock assembly and have a cap or cover to prevent debris from entering and preventing access to the lock assembly. Keys for all lock assemblies will be provided to the City. The frame and cover assembly shall be capable of withstanding a test load of 100,000 lbs and include a "T" shaped durable gasket to cushion traffic shock and resist water infiltration. The frame and cover assembly shall be circular, compatible with City of Federal Way standard top slab openings, and available in a 24-inch clear opening. The frame and cover depth shall not exceed 4 inches and the flange shall incorporate bedding slots and bolt holes. The cover shall be installed with the hinge facing oncoming traffic so the lid will open towards traffic.

Heavy-Duty Hinged Style Frame & Cover shall be ERGO Assembly: Product Number 00104040L01, Manufactured by EJ Group, Inc., 301 Spring Street, PO Box 439, East Jordan, MI 49727, (800)626-4653, www.ejco.com

9-05.15(5) High Impact Multi-Purpose Rubber Composite Adjustment Risers

(December 2, 2019 CFW GSP)

Section 9-05.15(5) is a new section:

Risers shall be minimum 80% by weight recycled rubber and minimum 10% by volume recycled RFL fiber. Adjustment risers shall be of uniform quality and free from cracks, holes, and any other surface defects. Adjustment risers shall be designed for heavy duty street traffic and shall meet or exceed minimum load capacity requirements of AASHTO. Adjustment risers shall be installed as a single unit and shall not be cut into pieces or used as shims. Manufacturer certification shall be furnished upon request stating that the product meets the requirements of this specification. Risers shall be available in standard thicknesses from 1/2-inch to 3-inches; available flat or tapered; and in round, square, and rectangular shapes.

High Impact Adjustment Riser shall be Infra-Riser Multi-Purpose Rubber Composite Adjustment Riser, EJ Group, Inc., 301 Spring Street, PO Box 439, East Jordan, MI, 49727, (800)626-4653, www.ejco.com

9-14 EROSION CONTROL AND ROADSIDE PLANTING

9-14.1 Materials Submittals and Acceptance

(January 10, 2022, WSDOT GSP, OPT1.2023)

In the table in Section 9-14.1, the row for Compost is revised to read:

CITY OF FEDERAL WAY

21ST AVE S & S 320TH STREET
SIGNALIZATION AND PEDESTRIAN
IMPROVEMENTS PROJECT
PROJECT #36225

SP-140

9-14.5(8)	Compost	<p>Cert & following information is required to be submitted fourteen days prior to application.</p> <ul style="list-style-type: none"> a) A copy of the Solid Waste Handling Permit issued to the manufacturer by the Jurisdictional Health Department in accordance with https://apps.leg.wa.gov/WAC/default.aspx?cite=173-350 (Minimum Functions Standards for Solid Waste Handling). b) Compost Test Data submitted on WSDOT Form 220-038 that show the compost complies with the processes, testing, and standards specified in WAC 173-350 and this section. And independent Seal of Testing Assurance (STA) Program certified laboratory shall perform the testing within 90 calendar days of application. c) A copy of the manufacturer's annual Seal of Testing Assurance STA certification as issued by the U.S. Composting Council. d) A sample of the compost approved for use. e) A list of feed stocks by volume for each compost type. f) Compliance with the applicable section.
-----------	---------	-------------------------------------------------------------------------------------------------------------------------------------------------------------------------------------------------------------------------------------------------------------------------------------------------------------------------------------------------------------------------------------------------------------------------------------------------------------------------------------------------------------------------------------------------------------------------------------------------------------------------------------------------------------------------------------------------------------------------------------------------------------------------------------------------------------------------------------------------------------------------------------------------------------------------------------------------------------------------------------------------------------------------------------------------------------------------------------------------------------------------------------

9-14.2 Topsoil

9-14.2(1) Topsoil Type A
(June 12, 2020 CFW GSP)

Section 9-14.2(1) is supplemented with the following:

Topsoil Type A mix shall be 50% pure organic compost and 50% sand or sandy loam. The soil shall be high in organic content and comprised of fully composted and mature organic materials.

No fresh sawdust or other fresh wood by-products shall be added to extend the volume after the composting process.

Chemical and physical characteristics of Topsoil Type A shall comply with the following:

Screen Size	7/16" Maximum
Total Nitrogen	0.25% Minimum
Organic Matter	10% Minimum
pH Range	5.5 to 7.5
Conductivity	5 mmhos/cm Maximum

9-14.5 Mulch and Amendments

9-14.5(3) Bark or Wood Chips
(June 12, 2020 CFW GSP)

Section 9-14.5(3) is supplemented with the following:

CITY OF FEDERAL WAY

21ST AVE S & S 320TH STREET
**SIGNALIZATION AND PEDESTRIAN
IMPROVEMENTS PROJECT
PROJECT #36225**

SP-141

Bark or Wood Chip Mulch shall be medium grade composted ground fir or hemlock bark. The bark shall be uniform in color, free from weed seeds, sawdust and splinters. The moisture content of bagged mulch shall not exceed 22%. The acceptable size range of bark mulch material is ½" to 1" with maximum of 20% passing the ½" screen.

9-14.7 Plant Materials

9-14.7(2) Quality

(June 12, 2020 CFW GSP)

Section 9-14.7(2) is supplemented with the following:

Plant material shall be free from disfiguring knots, swollen grafts, sunscald injuries, bark abrasions, evidence of improper pruning or other objectionable disfigurement.

Potted and container stock shall be well rooted and vigorous enough to ensure survival and healthy growth. Shrubs shall have full foliage (not leggy). Container stock shall be grown in its delivery container for not less than six (6) months, but not for more than two (2) years. Root bound or broken containers will not be accepted. Bare root, liner and root stock with dried or shriveled roots from exposure will not be accepted.

Measurements, caliper, branching, grading, quality, balling and burlapping shall follow the Code of Standards of the American Associate of Nurserymen in the American Standard for Nursery Stock, ANSI 260.1, latest edition. Measurements shall be taken with all branches in their normal growing position. Plants shall not be pruned prior to delivery to site.

9-14.7(3) Handling and Shipping

(June 12, 2020 CFW GSP)

Section 9-14.7(3) is supplemented with the following:

Tie back branches as necessary, and protect bark from chafing with burlap bags. Do not drag Plant materials along ground without proper protection of roots and branches. Protect rootballs from environmental or mechanical damage and water as necessary to keep roots moist. Do not store Plants for more than one week.

9-14.7(4) Sod

(June 12, 2020 CFW GSP)

Section 9-14.7(4) is supplemented with the following:

Sod Lawn shall be three-way Tall Fescue Blend Sod, 33.33% Firecracker LS Tall Fescue, 33.33% Spyder LS Tall Fescue, 33.33% Raptor II Tall Fescue with degradable netting, or approved equal.

9-14.7(5) Tagging

(June 12, 2020 CFW GSP)

Section 9-14.7(5) is a new section::

All Plant material shall be legibly tagged. Tagging may be by species or variety with minimum of one tag per ten trees, shrubs, or vines. Remove all tagging prior to final acceptance.

CITY OF FEDERAL WAY

21ST AVE S & S 320TH STREET
SIGNALIZATION AND PEDESTRIAN
IMPROVEMENTS PROJECT
PROJECT #36225

SP-142

CFW SPECIAL PROVISIONS VER. 2023.06

*** PLAN CENTER COPY *** Official bid documents, plan holder's list, and addenda (if applicable) are available on BXWA.com

9-14.7(6) Inspection
(June 12, 2020 CFW GSP)

Section 9-14.7(6) is a new section:

The Contracting Agency shall reserve the option of selecting and inspecting Plant material at the nursery. The contractor shall provide the Contracting Agency with at least one week notice prior to preparing Plants for shipping and delivery. The Contractor shall neither deliver to site nor install Plant materials until authorized by the Contracting Agency.

9-14.7(7) Temporary Storage
(June 12, 2020 CFW GSP)

Section 9-14.7(7) is a new section:

Cold storage of Plants shall not be permitted.

If Planting is delayed more than 24 hours after delivery, set balled and burlapped Plants on the ground, well protected with soil or wet peat. Adequately cover all roots of bare root material with soil or wet peat. Protect rootballs from freezing, sun, drying winds or mechanical damage. Water Plant material as necessary until Planted.

Plants shall not be stored for more than one week. Longer storage period at project site will result in rejection of Plant materials by the Contracting Agency.

9-14.8 Stakes, Guys, and Wrapping
(June 12, 2020 CFW GSP)

Section 9-14.8 is supplemented with the following:

Stakes shall be BVC round tree stakes with Chainlock guying or Engineer accepted product. No wrapping required.

9-14.9 Root Barrier
(June 12, 2020 CFW GSP)

Add the following new section:

Root Barrier shall be 18-inch high, minimum thickness 0.090-inch, interlocking root barrier panels constructed of high-impact polypropylene with 1/2-inch reinforcing ribs.

9-15 IRRIGATION SYSTEM

9-15.1 Pipe, Tubing And Fittings
(June 12, 2020 CFW GSP)

Section 9-15.1 is replaced with the following:

All pipe and tubing shall be PVC or approved equal. All fittings shall be Sch 80 PVC. All pipe for the main, laterals, and sleeving shall be Sch 40 PVC.

9-15.5 Valve Boxes
(June 12, 2020 CFW GSP)

Section 9-15.5 is supplemented with the following:

Valve boxes for control valves shall be grey flared box, HDPE construction with UV inhibitors, heavy duty seat collar, drop in locking, 17" L x 24" D x 12" W with green HDPE drop in locking lid.

CITY OF FEDERAL WAY

21ST AVE S & S 320TH STREET
SIGNALIZATION AND PEDESTRIAN
IMPROVEMENTS PROJECT
PROJECT #36225

SP-143

Valve boxes for Double Check Valve Assembly shall be grey heavy duty polymer concrete, top dimensions 25”L x 15-16”W and 24” D designed to withstand H-10 and H-20 loading in incidental and non-deliberate traffic areas. Valve box must be compliant with AASHTO H-10 Design Load; ASTM C 857-95 Design Load of A-8, 8,000lbs. Box shall be alkaline, acid and weather resistant, with flush locking polymer concrete cover. Verify size to fit Double Check Valve Assembly.

Valve boxes for quick coupler shall be light duty HDPE with UV inhibitors, 10” diameter flared box with bolt down cover.

9-15.6 Gate Valves

(April 12, 2018 CFW GSP)

Section 9-15.6 is supplemented with the following:

Gate valves shall be heavy duty cast brass body and heavy cast iron handwheel, suitable for residential or commercial potable water applications, with screwed bonnet, non-rising stem, solid wedge disc and integral seats.

9-15.7 Control Valves

9-15.7(1) Manual Control Valves

(April 12, 2018 CFW GSP)

Section 9-15.7(1) is supplemented with the following:

Shut off valves upstream of automatic control valves shall be a heavy duty cast brass body gate valve with heavy cast iron handwheel, suitable for residential or commercial potable water applications, with screwed bonnet, non-rising stem, solid wedge disc and integral seats, size to fit line.

9-15.13 Pressure Regulating Valves

(April 12, 2018 CFW GSP)

Section 9-15.13 is supplemented with the following:

Pressure regulating valve shall be designed to reduce incoming water pressure from up to 400psi to a range of 25-75psi. Valve shall be all bronze body construction, with thermal expansion bypass, serviceable in line, with internal stainless steel strainer.

SECTION 9-19 DETECTABLE WARNING SURFACE

9-19.2 Cast-in-Place Detectable Warning Surface

9-19.2(1) General Requirements

(October 3, 2022 WSDOT GSP, OPTION 1)

The first paragraph of Section 9-19.2(1) is revised to read:

The color of detectable warning surfaces shall be yellow and shall match SAE AMS Standard 595, color number 33538 unless otherwise shown on the plans. When used in areas between ramps to differentiate between travel paths, detectable warning surfaces shall be black.

Units shall provide the required contrast (light-on-dark or dark-on-light) with the adjacent curb ramp or other applicable walkway.

CITY OF FEDERAL WAY

**21ST AVE S & S 320TH STREET
SIGNALIZATION AND PEDESTRIAN
IMPROVEMENTS PROJECT
PROJECT #36225**

SP-144

SECTION 9-28 SIGNING MATERIALS AND FABRICATION

9-28.1 General

(March 22, 2023 CFW GSP)

Paragraph three is deleted and replaced with the following:

All regulatory (R series), school (S series), and warning (W and X series) signs, except for parking regulation, parking prohibition signing and signs of fluorescent yellow-green color shall be constructed with Type III Glass Bead Retroreflective Element Material sheeting in accordance with Section 9-28.12 of the Standard Specifications. This sheeting has a retro reflection rating of 250 candelas/foot candle/square foot for white-silver sheeting with a divergence angle of 0.2 degrees and an incidence angle of minus 4 degrees. This high intensity sheeting shall be Type III sheeting or greater. All street name (D-3) sign sheeting shall meet this specification. The reflectivity standard of supplemental plaques shall match that of the primary sign.

All overhead signing, all regulatory (R series) of fluorescent yellow-green color and all school (S series) of florescent yellow color shall meet the specifications of Type IX Micro Prismatic Retroreflective Element Material sheeting in accordance with Section 9-28.12 of the Standard Specifications. This standard applies to all signs mounted above the roadway, on span wire or signal mast arms and all regulatory (R series) and school (S series) signs of fluorescent yellow-green color. The reflectivity standard of supplemental plaques shall match that of the primary sign.

Motorist information and parking signing shall be constructed with Type I Glass Bead Retroreflective Element Material sheeting in accordance with Section 9-28.12 of the Standard Specifications. The reflectivity standard of supplemental plaques shall match that of the primary sign.

9-28.2 Manufacturer's Identification and Date

(October 23, 2014 CFW GSP)

Section 9-28.2 is deleted and replaced with the following:

All signs shall show the manufacturer's name and date of manufacture on the back.

9-28.8 Sheet Aluminum Signs

(January 8, 2013 CFW GSP)

Section 9-28.8 table is deleted and replaced with the following:

<u>Maximum Dimension</u>	<u>Blank Thickness</u>
Less than 30 inches	0.080 inches
Greater than 30 inches, less than 48 inches	0.100 inches
Greater than 48 inches	0.125 inches

Section 9-28.8 is supplemented with the following:

All permanent signs shall be constructed from aluminum sign blanks unless otherwise approved by the Engineer. Sign-blank minimum thicknesses, based on maximum dimensions, shall be as follows:

CITY OF FEDERAL WAY

**21ST AVE S & S 320TH STREET
SIGNALIZATION AND PEDESTRIAN
IMPROVEMENTS PROJECT
PROJECT #36225**

SP-145

All D-3 street-name signs shall be constructed with 0.100-inch-thick blanks. The Contractor shall install permanent signs which meet or exceed the minimum reflectivity standards. All sign face sheeting shall be applied to sign blanks with pressure sensitive adhesives.

9-28.9 Fiberglass Reinforced Plastic Signs

(December 18, 2009 CFW GSP)

Section 9-28.9 is deleted in its entirety.

9-28.12 Reflective Sheeting

(February 6, 2023 WSDOT GSP)

Section 9-28.12 is revised to read:

Reflective sheeting material shall conform to ASTM D4956 – *Standard Specification for Retroreflective Sheeting for Traffic Control*. The following standard reflective sheeting types have been modified to reflect Contracting Agency requirements:

Device Type	Use	Sheeting Color	Allowable Sheeting Types
Permanent Signs			
Permanent Signing	All	All	IV ¹
Object Markers	All	All	IV
Temporary Construction Signing			
Warning Signs	All	Fluorescent Orange	VIII, IX, X ² , XI
Regulatory Signs	All	White	IV
Regulatory Signs	Rural	White	II ³ , IV
Regulatory Signs	Urban/Rural	White	III ³ , IV
Regulatory Signs	All	Red	III, IV
Regulatory Signs	All	Green	II, IV
Regulatory Letters, Border or Symbols		Green	III ³ , IV ³
Temporary Construction Signs	All	All Other Background Colors	III ³ , IV
Other Devices			
Barricades	All	White or Orange	III ³ , IV
Barrier Delineators	All	White or Yellow	III, IV, V, XI
Bollards	All	All	IV
Flexible Guidepost	All	All	III, IV, V
Pedestrian Channelization Devices	All	White or Orange	III ³ , IV
Signal Backplates	Portable Signals		IV
Signal Backplates	Permanent Signals		See Section 9-29.16
Tail Channelization Devices 42-inch	All	Fluorescent Orange/White	III ⁴ , IV ⁴ , VIII, IX, XI ⁴
Traffic Cones 28- and 36-inch	All	White or Higher White	III ³ , IV
Traffic Safety Drums	All	Fluorescent Orange/White	III ⁴ , IV ⁴ , VIII, IX, XI ⁴

CITY OF FEDERAL WAY

21ST AVE S & S 320TH STREET
**SIGNALIZATION AND PEDESTRIAN
IMPROVEMENTS PROJECT
PROJECT #36225**

SP-146

CFW SPECIAL PROVISIONS VER. 2023.06

*** PLAN CENTER COPY *** Official bid documents, plan holder's list, and addenda (if applicable) are available on BXWA.com

Transportable Attenuators	All	Yellow and Black Chevron	III ³ , IV
Transportable Attenuators	All	White and Red Chevron	IV
Utilities attached to Bridges	All		I, See Section 6-01.10

Notes:

1. Except S Series signs with fluorescent yellow-green sheeting shall use Type XI and Overhead Warning Signs and overhead exit only panels with fluorescent yellow shall use Type IV or XI.
2. Former Type X, not shown in ASTM D4956, however meets requirements of Types VII, IX and XI.
3. Only devices in inventory may be used, new fabrication shall use Type IV.
4. Type III and Type IV orange and white sheeting may be still used through December 31, 2026.

9-28.14 Sign Support Structures
(March 22, 2023 CFW GSP)

Section 9-28.14 is supplemented with the following:

Unless otherwise noted in the Plans or approved by the engineer, all sign posts shall be steel sign posts. Sign post sizes will be shown on Plans or shall be sized per the WSDOT Design Manual. Sign Supports (foundations) shall be Type ST-4 (concrete) as found on WSDOT Standard Detail G-24.50-05.

SECTION 9-29 ILLUMINATION, SIGNAL, ELECTRICAL

9-29.1 Conduit, Innerduct, and Outerduct
(October 23, 2014 CFW GSP)

Fiber optic cable conduit shall be supplied as a system from a single manufacturer providing all of the conduit, all required fittings, termination and other installation accessories; all in accordance with the Contract Documents.

9-29.1(11) Foam Conduit Sealant
(January 7, 2019 WSDOT Option 1)

Section 9-29.1(11) is supplemented with the following:

The following products are accepted for use as foam conduit sealant:

- CRC Minimal Expansion Foam (No. 14077)
- Polywater FST Foam Duct Sealant
- Superior Industries Foam Seal
- Todo! Duo Fill 400

9-29.2 Junction Boxes, Cable Vaults and Pull Boxes
(August 27, 2021 CFW GSP)

Section 9-29.2 is supplemented with the following:

CITY OF FEDERAL WAY

21ST AVE S & S 320TH STREET
SIGNALIZATION AND PEDESTRIAN
IMPROVEMENTS PROJECT
PROJECT #36225

SP-147

Slip-Resistant Surfacing for Junction Boxes, Cable Vaults, Fiber Vaults, and Pull Boxes

All lids located within sidewalk areas, along an ADA pedestrian route, or in other accessible surfaces within the public right-of-way or on publicly owned properties, must meet ADA requirements and be slip-resistant. Acceptable slip-resistant products shall be non-slip MMA coating. Placement of the non-slip MMA coating shall be in accordance with the manufacturer's recommendations. Vertical edges of the utility shall be flush with the adjoining surface to the extent possible after installation.

9-29.2(1)A2 Non-Concrete Junction Boxes ***(February 3, 2020 CFW GSP)***

Section 9-29.2(1)A2 is replaced with the following:

Non-Concrete junction boxes are not allowed for use within the City of Federal Way.

9-29.2(5)E Fiber Vaults ***(March 15, 2012 CFW GSP)***

Section 9-20.2(5)E is a new section:

Where fiber vaults are called for on the Drawings, the Contractor shall provide pre-cast utility vaults meeting ASTM C 478 with twenty-eight (28) day 5500 psi minimum compressive strength concrete and designed for H-20 loading unless otherwise indicated on the Drawings.

The communications/fibers vault, shall be a type 444-LA manufactured by Oldcastle Precast, Inc. or approved equivalent, or a WSDOT Pull Box or cable vault per WSDOT Standard Plan J.90.10 and J.90.20. The fiber vaults are to be provided with a racking hardware package for cable storage and mounting of the splice case. The vault cover shall have a bolt-down, non-skid surface and a ground strap.

Fiber vaults shall contain a splice enclosure.

Fiber Optic Splice Closure shall be a Coyote Closure manufactured by Preformed Line Products or equivalent, shall be suitable for both vault and aerial applications, and shall meet the following requirements:

1. Be made of two injection-molded high-density thermoplastic shells, be 22 inches in length and 6 inches in diameter, and have capacity to store up to four splice trays.
2. Each splice case shall have two end plates; one end plate shall have no ports, the other endplate shall consist of a three section end plate with six ports - two 3/4-inch ports and four 7/8-inch ports. Each unused port shall have a grommet installed. The end plates shall be durable glass-filled high-density thermoplastic shells.
3. The splice enclosure shall be suitable for outdoor applications with a temperature range of -10°C to 60°C.
4. The splice enclosure shall provide sufficient space to allow entry of fiber optic cable without exceeding the cable minimum bending radius.

5. The enclosure shall protect the splices from moisture and mechanical damage and shall be resistant to corrosion.
6. The enclosure shall be waterproof, re-enterable and shall have a neoprene gasket sealing system to prevent water from entering.
7. The enclosure shall permit selective splicing to allow one or more fibers to be cut and spliced without disrupting other fibers.
8. The enclosure shall have strain relief for the cable to prevent accidental tension from disturbing the splices.
9. Each splice tray will be able to store 36 splices securely. Each splice shall be individually mounted and mechanically protected on the splice tray. Vinyl markers shall be supplied to identify each fiber spliced within the enclosure.

9-29.3 Fiber Optic Cable, Electrical Conductors and Cable
(December 13, 2012 CFW GSP)

Section 9-29.3 is supplemented with the following:

Video cable from the camera (sensor) to the controller cabinet shall conform to the video detection manufacturer's recommendations.

9-29.3(2)F Detector Loop Wire
(April 12, 2018 CFW GSP)

Section 9-29.3(2)F is modified as follows:

Detector loop wire shall use 14 AWG stranded copper conductors, and shall conform to IMSA Specification 51-7, with cross-linked polyethylene (XLPE) insulation encased in a polyethylene outer jacket (PE tube).

9-29.3(2)H Three-Conductor Shielded Cable
(March 13, 2012 CFW GSP)

Section 9-29.3(2)H is supplemented with the following:

Lead-in cable back to the controller for pre-emption units shall be 6TT detector 138 cable or equivalent.

9-29.3(2)I Twisted Pair Communications Cable
(October 23, 2014 CFW GSP)

Section 9-29.3(2)I is deleted in its entirety. See Section 8-20.3(8)A.

9-29.6 Light and Signal Standards
(December 18, 2009 CFW GSP)

Section 9-29.6 is supplemented with the following:

Light standards shall be tapered round aluminum tube C-wall alloy 6063 satin brushed finish with Davit bracket arm, as shown in Federal Way Standard Detail herein, except that luminaire mounting height shall be as shown on the Illumination Pole Schedule.

(June 6, 2023 WSDOT GSP, OPTION 5)

Section 9-29.6 is supplemented with the following:

Traffic Signal Standards

Traffic signal standards shall be furnished and installed in accordance with the methods and materials noted in the applicable Standard Plans, pre-approved plans, or special design plans.

All welds shall comply with the latest AASHTO Standard Specifications for Structural Supports for Highway Signs, Luminaires and Traffic Signals. Welding inspection shall comply with Section 6-03.3(25)A Welding Inspection.

Hardened washers shall be used with all signal arm connecting bolts instead of lockwashers. All signal arm ASTM F 3125 Grade A325 connecting bolts tightening shall comply with Section 6-03.3(33).

Traffic signal standard types, applicable characteristics, and foundation types are as follows:

Type PPB

Pedestrian push button posts shall conform to Standard Plan J-20.10 or to one of the following pre-approved plans:

Fabricator	Pre-Approved Drawing No.
Valmont Ind. Inc.	DB01165 Rev. B (4 sheets)
Ameron Pole Products Division	WA15TR10-1 Rev. C (1 sheet) and WA15TR10-3 Rev. B (1 sheet)
Millerbernd Manufacturing, Co.	74514-WA-PED-PPB Rev J (2 sheets)

Foundations shall be as noted in Standard Plan J-20.10

Type PS, Type I, Type RM, and Type FB

Type PS pedestrian signal standards, Type I vehicle signal standards, Type RM ramp meter signal standards, and Type FB flashing beacon standards shall conform to Standard Plan J-20.16, J-21.15, J-21.16, and J-22.15 respectively, or to one of the following pre-approved plans:

Fabricator	Pre-Approved Drawing No.
Valmont Ind. Inc.	DB01165 Rev. B (4 sheets)
Ameron Pole Products Division	WA15TR10-1 Rev. C (1 sheet) and WA15TR10-2 Rev. C (1 sheet)
Millerbernd Manufacturing, Co.	74514-WA-PED-FB Rev. H (2 sheets)
Millerbernd Manufacturing, Co.	74514-WA-PED-SB Rev H (2 sheets)

Foundations shall be as noted in Standard Plan J-21.10.

Type II

CITY OF FEDERAL WAY

**21ST AVE S & S 320TH STREET
SIGNALIZATION AND PEDESTRIAN
IMPROVEMENTS PROJECT
PROJECT #36225**

SP-150

Type II signal standards are single mast arm signal standards with no luminaire arm or extension. Type II standards shall conform to one of the following pre-approved plans. Maximum arm length (in feet) and wind load (XYZ value, in cubic feet) is noted for each manufacturer.

Fabricator	Pre-Approved Drawing No.	Max. Arm Length (ft)	Max. Wind Load (XYZ) (ft³)
Valmont Ind., Inc.	DB00162 Rev. B (5 sheets)	65	3206
Ameron Pole Products Division	WA15TR3724-1 Rev. C (sheet 1 of 2), and WA15TR3724-2 Rev. D (sheet 2 of 2)	65	2935
Millerbernd Manufacturing, Co.	74516-WA-TS-II Rev. L (4 sheets)	65	3697

Foundations shall be as noted in the Plans and Standard Plan J-26.10. Type II signal standards with two mast arms installed 90 degrees apart may use these pre-approved drawings. Standards with two arms at any other angle are Type SD and require special design.

Type III

Type III signal standards are single mast arm signal standards with one Type 1 (radial davit type) luminaire arm. The luminaire arm has a maximum length of 16 feet and a mounting height of 30, 35, 40, or 50 feet, as noted in the Plans. Type III standards shall conform to one of the following pre-approved plans. Maximum arm length (in feet) and wind load (XYZ value, in cubic feet) is noted for each manufacturer. Wind load limit includes a luminaire arm up to 16 feet in length.

Fabricator	Pre-Approved Drawing No.	Max. Arm Length (ft)	Max. Wind Load (XYZ) (ft³)
Valmont Ind., Inc.	DB00162 Rev. B (5 sheets), with Type "J" luminaire arm	65	3259
Ameron Pole Products Division	WA15TR3724-1 Rev. C (sheet 1 of 2), and WA15TR3724-2 Rev. D (sheet 2 of 2), with Series "J" luminaire arm	65	2988
Millerbernd Manufacturing, Co.	74516-WA-TS-III Rev. L (5 sheets)	65	3750

Foundations shall be as noted in the Plans and Standard Plan J-26.10. Type III signal standards with two mast arms installed 90 degrees apart may use these pre-approved drawings. Standards with two arms at any other angle are Type SD and require special design.

Type IV

Type IV strain pole standards shall be consistent with the Plans and Standard Plan J-27.15 or one of the following pre-approved plans:

Fabricator	Pre-Approved Drawing No.
Valmont Ind. Inc.	DB01167 Rev. B (2 sheets)
Ameron Pole Products Div.	WA15TR15 Rev. A (2 sheets)
Millerbernd Manufacturing, Co.	74554-WA-SP-IV Rev H (2 sheets)

Foundations shall be as noted in the Plans and Standard Plan J-27.10.

Type V

Type V strain poles are combination strain pole and light standards, with Type 1 (radial davit type) luminaire arms. Luminaire arms may be up to 16 feet in length, and a mounting height of 40 or 50 feet, as noted in the Plans. Type V strain poles shall be consistent with the Plans and Standard Plan J-27.15 or one of the following pre-approved plans:

Fabricator	Pre-Approved Drawing No.
Valmont Ind., Inc.	DB01167 Rev. B (2 sheets),
Ameron Pole Products Div.	WA15TR15 Rev. A (2 sheets)
Millerbernd Manufacturing, Co.	74554-WA-SP-V Rev J (3 sheets)

Foundations shall be as noted in the Plans and Standard Plan J-27.10.

Type CCTV

Type CCTV camera pole standards shall conform to Standard Plan J-29.15 or to one of the following pre-approved plans:

Fabricator	Pre-Approved Drawing No.
Valmont Ind. Inc.	DB01166 Rev. C (4 sheets)
Ameron Pole Products Div.	WA15CCTV01 Rev.B (2 sheets)
Millerbernd Manufacturing, Co.	74577-WA-LC1 Rev H (2 sheets)
Millerbernd Manufacturing, Co.	74577-WA-LC2 Rev. H (2 sheets)
Millerbernd Manufacturing, Co.	74577-WA-LC3 Rev H (3 sheets)

Foundations shall be as noted in the Plans and Standard Plan J-29.10.

Type SD

Type SD signal standards are outside the basic requirements of any pre-defined signal standard and require special design. All special design shall be based on the latest AASHTO Standard Specifications for Structural Supports for Highway Signs, Luminaires and Traffic Signals and pre-approved plans and as follows:

1. A 115 mph wind loading shall be used.
2. The Mean Recurrence Interval shall be 1700 years.
3. Fatigue category shall be III.

Complete calculations for structural design, including anchor bolt details, shall be prepared by a Professional Engineer, licensed under Title 18 RCW, State of Washington, in the branch of Civil or Structural Engineering or by an individual holding valid registration in another state as a civil or structural Engineer.

All shop drawings and the cover page of all calculation submittals shall carry the Professional Engineer's original signature, date of signature, original seal, registration number, and date of expiration. The cover page shall include the contract number, contract title, and sequential index to calculation page numbers. Two copies of the associated design calculations shall be submitted for approval along with shop drawings.

Details for handholes and luminaire arm connections are available from the Bridges and Structures Office.

Foundations for Type SD standards shall be as noted in the Plans.

9-29.6(1) Steel Light and Signal Standards ***(December 18, 2009 CFW GSP)***

Section 9-29.6(1) is supplement with the following:

Traffic signal standards and illumination standards shall be furnished and installed in accordance with the methods and materials noted in the applicable Standard Plans, pre-approved plans, or special design plans. All welds shall comply with the latest AASHTO Standard Specifications for Support of Highway Signs, Luminaires, and Traffic Signals. Welding inspection shall comply with Section 6-03.3(25)A, Welding Inspection.

All traffic signal standards and arms shall be round tapered.

After delivering the poles or arms to the job site and before they are installed, they shall be stored in a place that will not inconvenience the public. All poles and arms shall be installed in compliance with Washington State Utility and Electrical Codes.

CITY OF FEDERAL WAY

SP-153

**21ST AVE S & S 320TH STREET
SIGNALIZATION AND PEDESTRIAN
IMPROVEMENTS PROJECT
PROJECT #36225**

CFW SPECIAL PROVISIONS VER. 2023.06

***** PLAN CENTER COPY *** Official bid documents, plan holder's list, and addenda (if applicable) are available on BXWA.com**

Terminal cabinet(s) shall be installed on all Type II and Type III signal poles or where designated on the wiring diagrams in the Plans in accordance with the material requirements of Section 9-29.25 of the Standard Specifications. Terminal cabinets shall be installed at a height not to impede pedestrians.

Galvanized steel light and signal standards shall not be painted.

9-29.6(5) Foundation Hardware
(January 13, 2021, WSDOT GSP, OPTION 1)

Section 9-29.6(5) is supplemented with the following:

Anchor bolt assemblies for light standards installed on top of barrier (median barrier mount) shall consist of the following:

- (4) 1-inch diameter threaded rods (bolts), minimum 36 inches in length
- (24) heavy hex nuts, six per anchor rod
- (24) flat washers, six per anchor rod
- Two anchor plates

Each anchor plate shall be constructed from 1/2" ASTM A36 plate and hot-dip galvanized in accordance with AASHTO M111. Each anchor plate shall be ring shaped, with an outside diameter of 16 inches and an inside diameter of 12 inches. Each anchor plate shall have four 1 1/8" diameter holes on a 13.89" bolt circle, with the holes positioned to match the anchor rod layout shown in the Standard Plans.

Anchor rods shall extend a minimum of five inches and a maximum of six inches above the top of the traffic barrier. The lower anchor plate shall be embedded 29 inches below the top of the traffic barrier. Each anchor plate shall be clamped with a heavy hex nut and washer above and below the anchor plate. The lower heavy hex nut for the pole base plate shall be no more than one inch from the top of the traffic barrier.

9-29.7 Luminaire Fusing and Electrical Connections at Light Standard Bases, Cantilever Bases, and Sign Bridge Bases

9-29.7(2) Fused Quick-Disconnect Kits
(March 13, 2012 CFW GSP)

Section 9-29.7(2) is supplemented with the following:

Fused quick-disconnect kits shall be of the SEC type or equivalent. Underground illumination splices shall be epoxy or underground service buss/light connector kits. Installation shall conform to details in the Standard Plans.

9-29.10 Luminaires
(March 7, 2018 CFW GSP)

Section 9-29.10 paragraph 3 and 4 are deleted and replaced with the following:

CITY OF FEDERAL WAY

21ST AVE S & S 320TH STREET
SIGNALIZATION AND PEDESTRIAN
IMPROVEMENTS PROJECT
PROJECT #36225

SP-154

All cobra-head style roadway luminaires shall be provided with markers for positive identification of light source type and wattage in accordance with ANSI C136.15-2011 with whole number wattage value and "LED" text. Legends shall be sealed with transparent film resistant to dust, weather, and ultraviolet exposure.

9-29.10(1) Conventional Roadway Luminaires

(March 22, 2023 CFW GSP)

Section 9-29.10(1) is supplemented with the following:

New roadway luminaire installations shall be cobra-head style light-emitting diode (LED), wattage per plan, with 7-pin photocell receptacle and shall be supplied and installed by the Contractor. The terminal board shall have lugs of a 240-volt 3-wire power source. Terminals shall be labeled line-neutral-line. The neutral terminal shall be grounded to the metal housing of the luminaire. The LED luminaire shall be factory set to produce IES pattern Type II.

Conductors serving the luminaires shall be copper of the size shown in the Plans and shall run to the service pole in separate conduit from the signal conductors as shown in the plan view. Fused quick disconnect wye cable connector kits shall be installed at the handhole inside the base of each pole supporting a luminaire. Top conductors from the pole base to the luminaire shall be a minimum No. 12 stranded copper. The grounding conductor shall be connected to the neutral terminal in the luminaire fixture.

Pole type and mounting heights shall be as specified in the Contract Plans and Standard Plans.

9-29.10(2) Vacant

(January 11, 2019 CFW GSP)

Section 9-29.10(2) is deleted and replaced with the following new section:

9-29.10(2) Decorative Luminaires

Section 9-29.10(2) is supplemented with the following:

All new decorative luminaire installations shall be light-emitting diode (LED) luminaires. LED luminaires must meet City standards for average maintained footcandles, uniformity ratio, mounting height, distribution pattern, and spacing as indicated in City of Federal Way Development Standard Drawing 3-42. LED luminaires shall have a correlated color temperature (CCT) of 4000K.

Pole and fixtures shall meet requirements of Special Provision 8-20.3(13)B, Decorative Light Standards.

9-29.10(3) Vacant

(December 16, 2022 CFW GSP)

Section 9-29.10(3) is deleted and replaced with the following new section:

9-29.10(3) L.E.D. Roadway Luminaires

All new roadway luminaire installations shall be Eaton Archeon light-emitting diode (LED) luminaires. Part numbers differ depending on the designed wattage specified as follows:

40/60 W: ARCH-S-PA1-50-740-U-T2R-AP-10K-PR7

CITY OF FEDERAL WAY

21ST AVE S & S 320TH STREET
SIGNALIZATION AND PEDESTRIAN
IMPROVEMENTS PROJECT
PROJECT #36225

SP-155

LED luminaires shall be furnished and installed by the Contractor. The units shall meet City standards for wattage, average maintained footcandles, uniformity ratio, mounting height, and distribution pattern, spacing, and model as indicated in City of Federal Way Development Standard Drawings 3-38 and 3-42. LED luminaires shall have a correlated color temperature (CCT) of 4000K and minimum color rendering index (CRI) of 70. Any variations from this standard must be approved by the City Traffic Engineer and shall require a lighting design performed by a Licensed Engineer. The Contractor shall provide a photometric plot of the proposed streetlight system and line loss calculations for these variation requests.

Units shall incorporate the following features:

1. A housing with 2.5-degree leveling steps capable of being mounted on a standard 2-inch roadway pole pipe tenon.
2. A housing and door manufactured from a die-cast low copper alloy aluminum designed to minimize corrosion.
3. Electrical components accessible through a swing-down entry door secured by a trigger latch or similar tool-less entry mechanism.
4. Resistance to vibration and impact, 3G vibration rated.
5. Provisions for installing a 7-pin photoelectric cell.
6. An LED light engine protected from the elements by a prismatic glass lens.
7. A thermal management system that promotes maximum air flow through the luminaire to ensure a minimum of 60,000 hours of operation at 25 degree centigrade with 90% lumen maintenance.
8. Protection against solar heating when not in operation.
9. Dark sky optics.
10. Glass tertiary optics that will not discolor or become brittle over time.
11. Sealed optics system rated for IP66 against water and dirt infiltration.
12. Surge protection module to protect the LED drivers, photo controls, transfer switches, and relays from electrical disturbances as defined by ANSI/IEEE C62.41, Category C. The unit shall be replaceable through the use of modular plug and wiring.
13. Solid state multi volt electrical drivers with a rated life of 50,000 hours.
14. Electrical drivers mounted in a heat sink and located such that they are isolated from heating by the sun when not in use.
15. 7-Pin Photo control receptacle that is adjustable without tools and is designed to meet UI1598 specifications for wet operation.

Retro-fit Existing Luminaires

LED luminaires shall be installed when existing luminaire replacement is required. Replacement LED luminaires shall meet the requirements of this chapter.

9-29.11 Control Equipment

9-29.11(2) Photoelectric Control

(January 11, 2019 CFW GSP)

Section 9-29.11(2) is supplemented with the following:

One CIMCON control node, model #iSLC-3100-7P-U-A-G-IO-CATB-05-T shall be installed on the top of each cobra head roadway luminaire.

9-29.13 Control Cabinet Assemblies

9-29.13(2) Traffic Signal Controller Assembly Testing

(October 23, 2014 CFW GSP)

Section 9-29.13(2) is supplemented with the following:

Replace all references to "WSDOT Materials Laboratory", "WSDOT facility", and "WSDOT" with "King County Traffic Maintenance".

9-29.13(3) Traffic Signal Controller

(November 17, 2014 CFW GSP)

Section 9-29.13(3) is supplemented with the following:

Equipment includes the following:

- Quantity One (1) – NEMA TS2 Type 1 or Type 2 cabinet with 16 position load bay.
- Quantity One (1) – TS2 Controller unit Cobalt.
- Quantity One (1) – Type 16 Malfunction Management Unit EDI 16LE.
- Quantity One(1) – TS2 Detector racks capable of 16 channels.
- Quantity One (1) – TS2 Power Supply.
- Auxiliary equipment so as to form completely functional eight phase traffic signal control cabinets.
- Video Detection Equipment and Advanced Loop Detection Equipment.
- Fiber Optic Patch Panel - __ fiber count.
- Fiber Optic Ethernet Switch(s).
- Fiber Optic Patch Cords.

Documentation and Training

Contractor to supply complete technical information, shop drawings, schematic diagrams, photographs, circuit diagrams, programming and operation instruction manuals, and any other necessary documents to fully describe the proposed equipment.

Schematics & Manuals: The cabinet(s) shall have a waterproof envelope with a side access attached to the inside of the door. At the time of delivery the envelope shall have two complete sets of schematics and manuals for all assemblies and sub-assemblies. In addition, the cabinet shall arrive with two sets of cabinet prints and one disk copy of the cabinet print in AutoCAD format including circuit schematics for each model of the following:

1. Controller
2. Conflict Monitor
3. Opticom Equipment
4. Video Detection Equipment
5. Fiber Optic Communication Equipment

The supplier shall provide a minimum of a one-day (8 hour) training session, given by qualified technical representative(s) of the manufacturer's firm. The sessions shall be conducted at the County and the training sessions shall be coordinated with the City Traffic Engineer. The supplier shall contact the City Traffic Engineer approximately three weeks prior to delivery of the equipment for the purpose of discussing the format and scheduling of the training sessions. The sessions shall be conducted within five (5) working days AFTER delivery of the equipment.

The training sessions shall as a minimum meet the following requirements:

1. Session 1: Basic operation, detector programming, special configuration programming, and time of time of day operation. This would cover operator front panel instruction for each component (i.e., Controller, Malfunction Management Unit, and Detector).
2. Session 2: Preemption, telemetry, diagnostics, cabinet operation, preventative maintenance, computer software, and troubleshooting. Technical maintenance and troubleshooting instruction shall be the main focus.
3. Presentations shall be made by "factory trained personnel". Supplier shall provide all necessary equipment needed for the training.

The instructional materials provided with the training sessions shall include the following information:

1. Table of Contents
2. Operating Procedure
3. Theory of Operation
4. Maintenance and Troubleshooting Information
5. Circuit Wiring Diagrams
6. Pictorial Diagrams of Part Locations
7. Timing Sheet

The controller shall be a NEMA TS2 controller, specifically, an Econolite Cobalt and be installed within a complete NEMA TS2 Type 1 eight phase signal cabinet.

CITY OF FEDERAL WAY

**21ST AVE S & S 320TH STREET
SIGNALIZATION AND PEDESTRIAN
IMPROVEMENTS PROJECT
PROJECT #36225**

SP-158

CFW SPECIAL PROVISIONS VER. 2023.06

***** PLAN CENTER COPY *** Official bid documents, plan holder's list, and addenda (if applicable) are available on BXWA.com**

9-29.13(5) Flashing Operations

(February 2, 2012 CFW GSP)

Section 9-29.13(5) is modified as follows:

Paragraph 2, Item 2 is deleted and replaced with the following:

Police Flash Switch - The switch shall have two positions, "Auto" and "Flash". The up position shall be "Auto" and result in normal signal operation. The down position shall be "Flash" and will put the signal into flashing operation and apply stop time to the controller. When the flash switch is returned to the "Automatic" position, the controller shall restart except when the conflict monitor has commanded flash operation. The effect shall be to disable the police panel when the conflict monitor has detected a malfunction and all controller and conflict monitor indications shall be available to the technician regardless of the position of the police panel flash. The controller shall restart with all-flash for a preset period of time.

(March 15, 2012 CFW GSP)

Section 9-29.13(5) is supplemented with the following:

All cabinets shall be wired to flash red for all phases. Flashing display shall alternate between Phases 1, 2, 5, 6 and Phases 3, 4, 7, 8.

9-29.13(6) Emergency Preemption

(March 31, 2012 CFW GSP)

Section 9-29.13(6) is supplemented with the following:

Emergency Preemption System (EPS) equipment shall be compatible with the operational requirements of the existing Opticom brand (GTT (formerly 3M)) emitters, detectors, phase discriminators and confirmation lights owned by the City.

EPS equipment shall meet the following requirements:

1. Detector. The Contractor shall provide and install emergency preemption detectors at locations shown in the plans. The emergency preemption detectors shall be solid-state devices consisting of photoelectric cells and an amplifier mounted in weather-resistant housings. The detectors (GTT Model #711 or approved equal) shall be capable of detecting an optical signal generated by an Opticom brand emitter assembly (GTT). The detectors shall detect the optical signals from the emitter, amplify the signal, and transmit it to the phase discriminator. The detectors shall have a range control capable of being adjusted up to a maximum of 1/3 mile. Detectors shall be installed in a drilled and tapped hole in the top of the mast-arm or street-light arm, unless shown otherwise in the Plans. They shall be tightly fitted to point in the direction shown in the plan view.
2. Detector Lead-in Cable. The detector lead-in cable shall be GTT (formerly 3M) Opticom Model 138 shielded detector cable, or approved equal. No splicing will be allowed between the detector and

CITY OF FEDERAL WAY

**21ST AVE S & S 320TH STREET
SIGNALIZATION AND PEDESTRIAN
IMPROVEMENTS PROJECT
PROJECT #36225**

SP-159

CFW SPECIAL PROVISIONS VER. 2023.06

the controller cabinet. All lead in cables shall be connected to terminals in the controller cabinet as shown in the wiring diagram. The shields shall be grounded to the grounding bar.

3. Confirmation Light. Mounted below the OPTICOM detector there shall be placed a white, 100 watt (minimum), standard screw socket, flood light which shall indicate, by being on, when the preemption interval is in effect and the desired phase is being held in a green display, unless otherwise noted in the plans. Indicator lights shall be actuated by utilizing the unused yellow output of pedestrian signal switch packs.
4. Multimode Phase Selector. The phase selector shall be GTT (formerly 3M) Opticom Model 764 capable of communication both IR and GPS based systems.

Maintenance and operation manuals shall be furnished for all emergency preemption equipment to the City of Federal Way or its designated agents by the Contractor.

9-29.13(10)A Auxiliary Equipment for NEMA Controllers
(March 22, 2023 CFW GSP)

Section 9-29.13(10)A is modified as follows:

Paragraph 1, Item 1 is supplemented with the following:

All flasher units shall as a minimum meet NEMA TS-2 1992, Section 6 requirements and shall be EDI Model 810 or approved equal.

Paragraph 1, Item 2 is supplemented with the following:

All load switches shall as a minimum meet NEMA TS-2 1992, Section 6 requirements and shall be EDI Model 510 or approved equal.

Paragraph 1, Item 3a is deleted and replaced with the following:

A 50-amp main breaker shall be supplied. This breaker shall supply power to the controller, MMU, signals, cabinet power supply, and auxiliary panels.

Paragraph 1, Item 3b is deleted and replaced with the following:

A 15-amp auxiliary breaker shall supply power to the fan, light, and GFI outlet.

Paragraph 1, Item 3c is supplemented with the following:

Spare neutral buss bars shall be provided on the bottom left and right of the cabinet.

Paragraph 1, Item 3 is supplemented with the following:

- g. A normally-open, 60-amp, solid-state device, "Crydom CWA 4850 relay", or approved equivalent.
- h. The power panel shall be covered by an easily removable, clear Plexiglas cover.

CITY OF FEDERAL WAY

SP-160

**21ST AVE S & S 320TH STREET
SIGNALIZATION AND PEDESTRIAN
IMPROVEMENTS PROJECT
PROJECT #36225**

CFW SPECIAL PROVISIONS VER. 2023.06

***** PLAN CENTER COPY *** Official bid documents, plan holder's list, and addenda (if applicable) are available on BXWA.com**

Paragraph 1, Item 4 is supplemented with the following:

Inside the police door there shall be a flash switch, which shall be the only switch on that panel. The switch shall have two positions, "Auto" and "Flash". The up position shall be "Auto" and result in normal signal operation. The down position shall be "Flash" and will put the signal into flashing operation and apply stop time to the controller. The switch shall be a general-purpose bat style toggle switch with 0.688-inch-long bat. The switch shall have a protective cover, which must be lifted to operate the switch.

Paragraph 1, Item 6 is supplemented with the following:

Cabinets shall be equipped with a NEMA TS2 Type 16 Malfunction Management Unit.

Paragraph 1, Item 7, sub-paragraph 1 is deleted and the section is supplemented with the following:

The detector interface panel shall support up to 32 channels of detection and four channels of preemption devices.

Detector Racks

Two vehicle detector amplifier racks and two detector interface panels shall be provided in each cabinet. Each rack shall support up to 16 channels of loop detection, one 4-channel preemption device, and one BIU.

Paragraph 1, Item 8 is supplemented with the following:

There shall be terminal strips for field wiring in the controller cabinet. The terminals shall be numbered in accordance to the field wiring chart included in these Specifications. A common buss bar with a minimum of 15 spare terminals shall be available after the cabinet is fully wired. In addition, a 15 terminal bar shall be provided for the pedestrian common and a terminal shall be provided for each signal head neutral. The buss bars shall be located on the left side wall of the cabinet. Only King County numbers shall be shown, as described in Section 8-20.3(8).

Pedestrian Detector Field Wiring

All pedestrian detectors shall be connected between logic ground and their appropriate field terminal. The terminals shall be grouped together and located in the lower left side panel.

Main Panel and Wire Terminations

All wires terminated behind the main panel and other panels shall be SOLDERED. No pressure or solderless connectors shall be used. Printed circuit boards shall **NOT** be used on main panels.

Field Terminal Locations

Field terminals shall be located at the bottom of the backboard. Their order shall be left to right beginning with phase one and following the order of the load switches. Field terminals shall be of the Screw type per NEMA TS2 5.3.6.

Paragraph 1, Item 9 is supplemented with the following:

The cabinet shall be provided with a thermostatically-controlled (adjustable between 80-150 degrees F) ventilation fan and shall be installed in the top of the cabinet plenum.

Paragraph 1, Item 10 is deleted and replaced with the following:

The cabinet shall have an incandescent lighting fixture that shall be mounted on the inside top of the cabinet near the front edge. An on/off switch that is turned on when the cabinet door is opened and off when it is closed shall activate the incandescent light. The lamp socket shall be placed on the circuit with convenience outlets which shall be protected by a circuit breaker rated at 25 amps. An incandescent 150-watt bulb shall be provided.

Paragraph 1, Item 11 is supplemented with the following:

All Controller and Malfunction Management Unit cables shall be of sufficient length to access any shelf position. All cables shall be encased in a protective sleeve along their entire free length.

Color Coding

All cabinet wiring shall be color coded as follows:

Purple	=	MMU Wiring
Orange	=	Flash Color Programming
Brown	=	Green Signal Wiring
Yellow	=	Yellow Signal Wiring
Red	=	Red Signal Wiring
Blue	=	Controller wiring
Gray	=	DC ground
AC+	=	Black
AC-	=	White
Chassis Ground	=	Green

Paragraph 1 is supplemented with the following:

13. Main Panel Configuration - The main panel shall be fully wired in the following configuration:

- a) Sixteen (16) load sockets.
- b) Six (6) flash-transfer-relay sockets.
- c) One (1) flasher socket.
- d) Two (2) main panel rack slots for BIUs 1 and 2. Two rack slots for Terminal and Facilities BIU's 3 and 4 which shall be wired to nuMBERed terminal strips.
- e) Wiring for 2 detector racks and 1 Type-16 MMU.

14. Lightning Suppression - The cabinet shall be equipped with an Innovative Technologies Model HS-P-SP-120A-60A-RJ or approved equivalent surge arrester.
15. Convenience Outlets - One convenience outlet with a ground fault interrupter and a second convenience outlet without ground fault interrupter shall be furnished in the cabinet(s). The ground fault outlet shall be mounted one on right side of the cabinet, near the top shelf, and the non-ground fault outlet shall be mounted on the left side of the cabinet, near the top shelf. No outlets shall be mounted on the door. The convenience outlets shall be placed on the circuit with the lamp socket which shall be protected by a circuit breaker rated at 25 amps.
16. Loop Detector Units:
 - (a) Cabinets shall be supplied with eight 4-channel loop detectors minimum or sixteen 4-channel loop detectors maximum as shown in the Plans. Loop detectors shall meet TS2 Specifications.
 - (b) Equipment and loop detection for advanced loops shall be as shown in the Plans.
17. Telemetry Interface Panel - All cabinets shall be wired with a telemetry interface panel and telemetry connecting cable so as to work with the master cabinet. In addition, every cabinet shall also be wired for transient suppression (Model # EDCO PC642C-00-AD or approved equivalent).
18. Preemption - The cabinet shall be completely wired to accept and service calls from GTT (formerly 3M) Opticom, Model 764 multimode phase-selector modules and their related optical-detector units.
19. Buss Interface Unit - Buss interface units (BIUs) shall meet all TS2-1992 Section 8 requirements. In addition, all BIUs shall provide separate front panel indicator light emitting diode (LEDs) for Valid Data.
20. Cabinet Power Supply - The cabinet power supply shall as a minimum meet all TS2-1992, Section 5.3.5 requirements. All power supplies shall also provide a separate front panel indicator LED for each of the four outputs. Front panel banana jack test points for 24 VDC and logic ground shall also be provided.
21. Fiber Optic Interconnect - The cabinet shall be furnished with equipment to accommodate the fiber optic interconnect cable including an IFS model D9130 fiber to serial modem or approved equal and RuggedCom brand Ethernet switch(s) including RuggedSwitch RS900G (fiber only), RuggedSwitch RS900L (fiber and copper) and/or RuggedSwitch RS930L (copper only) or approved equal(s).
22. Inside Control Panel Switches - Service Panel Switches
 - (a) Power Switches: There shall not be a main power switch inside the cabinet(s) that shall render all control equipment electrically dead when turned off. There shall be a controller power switch that shall render the controller and load switching devices electrically dead while maintaining flashing operation for purposes of changing the controller or load switching devices. The switch shall be a general-purpose bat style toggle switch with .688-inch-long bat. The switch shall have a protective cover, which must be lifted to operate the switch.

CITY OF FEDERAL WAY

21ST AVE S & S 320TH STREET
SIGNALIZATION AND PEDESTRIAN
IMPROVEMENTS PROJECT
PROJECT #36225

SP-163

CFW SPECIAL PROVISIONS VER. 2023.06

*** PLAN CENTER COPY *** Official bid documents, plan holder's list, and addenda (if applicable) are available on BXWA.com

- (b) Stop Time Switch: There shall be a 3-position switch located inside the cabinet door identified as the Stop Time switch. Its positions shall be labeled “Normal” (up), “Off” (center), and “On” (down). With the switch in its Normal position, a stop timing command may be applied to the controller by the police flash switch or the conflict monitor unit. When the switch is in its “Off” position, stop-timing commands shall be removed from the controller. The “On” position of the switch shall cause the controller to stop timing. The switch shall be a general-purpose bat style toggle switch with .688-inch-long bat. The switch shall have a protective cover, which must be lifted to operate the switch.
- (c) Technician Flash Switch: There shall be a switch inside the cabinet to place the signal in flashing operation while the controller continues to operate. This flash shall have no effect on the operation of the controller or conflict monitor. The switch shall be a general-purpose bat style toggle switch with .688-inch-long bat. The switch shall have a protective cover, which must be lifted to operate the switch.
- (d) Detector Test Switches: All eight controller phase inputs shall have push button momentary test switches. Each switch shall be connected to the first channel of each detector card input to the BIU. All eight pedestrian phases shall have push button momentary test switches by phase. These switches shall be located inside the cabinet door and labeled by associated phase number. A see-through Plexiglas cover shall cover all detector disconnect/test switches.
- (e) Preempt Test Switches: All Six preempt inputs shall have disconnect/test switches. These switches shall have three positions labeled “Normal” (up) which shall connect the controller to the Opticom output: “Off” (center) which shall isolate the controller from the Opticom output: and “Test” (down) which shall provide a momentary true input to the controller.
- (f) Switches shall be in groups of eight (8), matching the phase groupings of the intersection.

Section 9-29.13(10)C is supplemented with the following:

- “Plug and Play” Cabinets are not acceptable.
- “Modular” Main Panels shall not be permitted.

Section 9-29.13(10)C is modified as follows:

Paragraph 1, Item 1 is deleted and replaced with the following:

Cabinet Construction

A complete NEMA TS2 Type 1 eight-phase cabinet shall be supplied and installed by the Contractor. The size of the cabinet shall be Type 6 (P 55”). Cabinets shall meet, as a minimum, all applicable sections of the NEMA Standard Publication No. TS2-1998. Where differences occur, this Specification shall govern. The cabinets shall meet the following criteria:

1. Material shall be 5052-H32 0.125-inch-thick aluminum.

2. The cabinet shall be supplied with a natural finish inside and out, unless otherwise specified.
3. The door hinge shall be of the continuous type with a stainless steel hinge pin.
4. All external fasteners shall be stainless steel.
5. The door handle shall be cast aluminum.
6. All seams shall be sealed with RTV sealant or equivalent material on the interior of the cabinet.

Paragraph 1, Item 2 is deleted and replaced with the following:

The cabinet shall contain shelving, brackets, racks, etc., to support the controller and auxiliary equipment. All equipment shall set squarely on shelves or be mounted in racks and shall be removable without turning, tilting, rotating or relocating one device to remove another.

Shelf Height

The cabinet shall be supplied with two removable shelves manufactured from 5052-H32 aluminum. The shelves must have the ability of being removed and reinstalled WITHOUT the use of hand tools.

Paragraph 1, Item 4 is supplemented with the following:

Air Filter Assembly

The cabinet air filter shall be a one-piece removable, noncorrosive, vermin- and insect-proof air filter and shall be secured to the air entrance of the cabinet.

Paragraph 1 is supplemented with the following:

6. Additional Panel Space - Adequate space shall be left open for the addition of a master interface panel and an AVI interface panel.

9-29.16 Vehicular Signal Heads, Displays, and Housings ***(February 24, 2012 CFW GSP)***

Section 9-29.16 is modified as follows:

Paragraph 2, is deleted and replaced with the following:

All lenses shall meet I.T.E. specifications for light output with 12-inch-diameter faces.

All vehicular signal heads shall be dark green baked enamel and shall be equipped with 5" wide black-polycarbonate back plates and black-polycarbonate tunnel visors of a length equal to the lens diameter. All hardware for attaching visors and back plates shall be non-corrosive stainless steel. Vehicle signal head polycarbonate materials shall not be painted. A 2-inch-wide strip of yellow retro-reflective, type IV prismatic sheeting, conforming to the requirements of Section 9-28.12, shall be applied around the perimeter of each backplate.

9-29.16(2) Conventional Traffic Signal Heads

CITY OF FEDERAL WAY

21ST AVE S & S 320TH STREET
SIGNALIZATION AND PEDESTRIAN
IMPROVEMENTS PROJECT
PROJECT #36225

SP-165

CFW SPECIAL PROVISIONS VER. 2023.06

*** PLAN CENTER COPY *** Official bid documents, plan holder's list, and addenda (if applicable) are available on BXWA.com

9-29.16(2)A Optical Units
(December 18, 2009 CFW GSP)

Section 9-29.16(2)A is deleted and replaced with the following:

Lenses shall be of the color indicated, circular in shape, with a visible diameter of 12 inches, as specified in the contract, and of such design as to give an outward and downward distribution of light with a minimum above the horizontal. The lenses shall be standard red, amber, and green, prisms traffic signal lenses and shall conform to the specifications of ITE Standards (Standards for Adjustable Face Vehicle Traffic Control Signal Heads, 1977 edition). The lenses shall fit into a red silicon gasket in a manner to render the interior of the lens and reflector weather and dust-tight. Signal heads shall have hinged aluminum reflector rings. The lens and gasket shall be secured to the door with four noncorrosive lens clips.

LED Traffic Signal Modules

All traffic signal displays shall be the Light Emitting Diode (LED) type and shall be from one of the following manufacturers:

Dialight Corporation Precision Solar Controls, Inc.
1913 Atlantic Avenue 2960 Market Street
Manasquan, NJ 08736 Garland, TX 75041
Telephone: (732) 223-9400 Telephone: (972) 278-0553
FAX: (732) 223-8788 FAX: (972) 271-9583

GELcore, LLC
6810 Halie Drive
Valley View, OH 44125
Telephone: (216) 606-6555
FAX: (216) 606-6556

Each LED signal module shall be designed to be installed in the doorframe of a standard traffic signal housing. The lamp socket, reflector, reflector holder, and lens used with an incandescent lamp shall not be used in a signal section in which a LED signal module is installed. The installation of an LED signal module shall not require any modification to the housing. The LED signal module shall be a single, self-contained device, not requiring on-site assembly for installation into an existing traffic signal housing.

All red LED signal modules shall be manufactured with a matrix of AlInGaP LED light sources and green LED signal modules shall be manufactured with a matrix of InGaN LED light sources. The LED traffic signal module shall be operationally compatible with controllers and conflict monitors on this Project. The LED lamp unit shall contain a disconnect that will show an open switch to the conflict monitor when less than 60 percent of the LEDs in the unit are operational.

Each LED signal module shall conform to the current standards in Institute of Transportation Engineers (ITE) VTCSH Part 2 and a Certificate of

CITY OF FEDERAL WAY

**21ST AVE S & S 320TH STREET
SIGNALIZATION AND PEDESTRIAN
IMPROVEMENTS PROJECT
PROJECT #36225**

SP-166

CFW SPECIAL PROVISIONS VER. 2023.06

***** PLAN CENTER COPY *** Official bid documents, plan holder's list, and addenda (if applicable) are available on BXWA.com**

Compliance with these standards shall be submitted by the manufacturer for each type of signal head. The certificate shall state that the lot of signal heads meets the current ITE specification. A label shall be placed on each LED signal module certifying conformance to this specification. The manufacturer's name, trademark, serial number and other necessary identification shall be permanently marked on the backside of the LED signal module. LED signal modules used on this Project shall be from the same manufacturer. A label shall be provided on the LED housing and the Contractor shall mark the label with a permanent marker to note the installation date.

LED signals shall show no evidence of illumination for input voltages below 35 volts. LED signals shall supply illumination current (unregulated) for all input voltages higher than 45 volts (and conform to appropriate intensity requirements specified above 80 volts).

The manufacturer shall provide a written warranty against defects in materials and workmanship for the LED signal modules for a period of 60 months after installation of the modules. All warranty documentation shall be given to the Engineer prior to installation.

9-29.16(2)B Signal Housing
(December 18, 2009 CFW GSP)

Section 9-29.16(2)B is supplemented with the following:

The signal housing shall be designed to withstand winds of 80 miles per hour with a 0.25-gust factor without permanent distortion or failing (torque at attachment of 6,000 pound-feet).

9-29.17 Signal Head Mounting Brackets and Fittings
(December 18, 2009 CFW GSP)

Section 9-29.17 is supplemented with the following:

Mast arm mounting hardware for vehicle signal heads shall be clamp style plumbizer PELCO AB-3008, or approved equal, and shall be field installed by the Contractor. Fittings shall be painted with two (2) coats of factory-applied traffic-signal dark green baked enamel. A watertight seal shall be provided where the signal head mounting bracket attaches to the mast arm or signal pole.

Components for type D and type K mounting hardware shall be per Section 9-29.17 of the Standard Specifications. All components shall be painted with traffic-signal dark green baked enamel.

9-29.18 Vehicle Detector

9-29.18(3) Video Detection System
(June 12, 2020 CFW GSP)

Section 9-29.18(3) is a new section:

All video detection system items and materials furnished shall be new, unused, current production models installed and operational in a user environment and shall be items currently in distribution. The products shall have a proven record of

CITY OF FEDERAL WAY

21ST AVE S & S 320TH STREET
SIGNALIZATION AND PEDESTRIAN
IMPROVEMENTS PROJECT
PROJECT #36225

SP-167

field use at other installations for at least two (2) years of service not including prototype field trials prior to installation. Contractor shall provide Econolite AutoScope Vision, Trafficon, GRIDSMART or approved equal video detection system. Approved equal video detection systems shall meet the following:

General

The detection of vehicles passing through the field-of-view of an image sensor shall be made available to a large variety of end user applications as simple contact closure outputs that reflect the current real-time detector or alarm state (on/off) or as summary traffic statistics that are reported locally or remotely. The contact closure outputs shall be provided to a traffic signal controller and comply with the National Electrical Manufacturers Association (NEMA) type C or D detector rack file standards.

The system architecture shall fully support Ethernet networking of system components through a variety of industry standard and commercially available infrastructures that are used in the traffic industry. The data communications shall support direct connect, modem and multi-drop interconnects. Simple, standard Ethernet wiring shall be supported to minimize overall system cost and improve reliability, utilizing existing infrastructure and ease of system installation and maintenance. Both streaming video and data communications shall be capable of being interconnected over long distance through fiber optic, microwave or other commonly used digital communications transport configurations.

In terms of the software application side of the network, the system shall be integrated through a client-server relationship. A communications server application shall provide the data communications interface between as few as one to as many as hundreds of Machine Vision Processors (MVP) sensors (otherwise referred to as video detection cameras with built in processors) and a number of client applications. The client applications shall either be hosted on the same PC as the communications server or may be distributed over a local area network of PC's using the industry standard TCP/IP network protocol. Multiple client applications shall execute simultaneously on the same host or multiple hosts, depending on the network configuration. Additionally, a web-browser interface shall allow use of industry standard internet web browsers to connect to MVP sensors for setup, maintenance and playing digital streaming video.

Approved equal GRIDSMART systems shall track individual vehicles entering the field of vision through detection zones from one camera located in the intersection, collect 24-hour approach volume, turning movement, and vehicle classification count data, and signal performance metrics. Larger intersections may require 2 cameras to include all advanced detection zones.

System Hardware

The video detection system hardware shall consist of the following components:

1. A color, 22x zoom Machine Vision Processor (MVP) sensor.
2. A modular cabinet interface unit.
3. A communication interface panel.
4. Surge suppresser/ lightning protection.

CITY OF FEDERAL WAY

**21ST AVE S & S 320TH STREET
SIGNALIZATION AND PEDESTRIAN
IMPROVEMENTS PROJECT
PROJECT #36225**

SP-168

CFW SPECIAL PROVISIONS VER. 2023.06

***** PLAN CENTER COPY *** Official bid documents, plan holder's list, and addenda (if applicable) are available on BXWA.com**

5. A portable color monitor to be permanently placed within the signal controller cabinet.
6. All other necessary equipment for setup, maintenance and operation of the video detection system including but not limited to programming device and specialty tools.

The real-time performance shall be observed by viewing the video output from the sensor with overlaid flashing detectors to indicate current detection state (on/off). The MVP sensor shall be capable of optionally storing cumulative traffic statistics internally in non-volatile memory for later retrieval and analysis.

The MVP shall communicate to the modular cabinet interface unit via the communications interface panel and the software applications using the industry standard TCP/IP network protocol. The MVP shall have a built-in, Ethernet-ready, Internet Protocol (IP) address and shall be addressable with no plug in devices or converters required. The MVP shall provide standard MPEG-4 streaming digital video. Achievable frame rates vary from 5 to 30 frames per second as a function of video quality and available bandwidth.

The modular cabinet interface unit shall communicate directly with up to eight (8) MVP sensors and shall comply with form factor and electrical characteristics to plug directly into a NEMA type C or D detector rack providing up to thirty-two (32) inputs and sixty-four (64) outputs to a traffic signal controller.

The communications interface panel shall provide four (4) sets of three (3) electrical terminations for three wire power cables for up to eight (8) MVP sensors that may be mounted on a pole or mast arm with a traffic signal cabinet or junction box. The communication interface panel shall provide high-energy transient protection to electrically protect the modular cabinet interface unit and connected MVP sensors. The communications interface panel shall provide single-point Ethernet connectivity via RJ45 connector for communication to and between the modular cabinet interface module and the MVP sensors.

The Gridsmart detection system shall consist of the following components and (part numbers):

1. One GRIDSMART ultra-wide angle fisheye camera with sealed enclosure. (GS-3-CAM) A second camera may be required at larger intersections as determined by the City Traffic Engineer.
2. One GRIDSMART GS2 Processing Unit, rack or shelf mount with two camera interface and GRIDSMART software. (GS-3-GS2)
3. One GRIDSMART TS2 Connector Kit for GS-3-GS2, includes SDLC connector to be used for TS2 environments. (GS2-TS2-OPT)
4. One SDLC Patch Cable, 6ft minimum. (WPS-SDLC)
5. One Swivel Bracket Camera Mounting Hardware with junction box and connector. (GS-3-SMC)
6. One Standard Cable Clamp, 66" cable length, natural aluminum finish. (SBC66-SCK)
7. One Video Detection Camera Mounting Arm Pole, 90 degrees, 58". (GS-3-A58)

CITY OF FEDERAL WAY

**21ST AVE S & S 320TH STREET
SIGNALIZATION AND PEDESTRIAN
IMPROVEMENTS PROJECT
PROJECT #36225**

SP-169

CFW SPECIAL PROVISIONS VER. 2023.06

***** PLAN CENTER COPY *** Official bid documents, plan holder's list, and addenda (if applicable) are available on BXWA.com**

8. Up to 300 feet of Detection Comm Cable, Ethernet, Cat 5E 350Mhz, outdoor rated, direct burial, CMX, Shielded, Gel. (CAT5)

System Software

The MVP sensor embedded software shall incorporate multiple applications that perform a variety of diagnostic, installation, fault tolerant operations, data communications, digital video streaming and vehicle detection processing. The detection shall be reliable, consistent and perform under all weather, lighting and traffic congestion levels. An embedded web server shall permit standard internet browsers to connect and perform basic configuration, maintenance and video streaming services.

There shall be a suite of client applications that reside on the host client/server PC. The applications shall execute under Microsoft Windows 7, Vista or XP. Client applications shall include:

1. Master network browser: Learn a network of connected modular cabinet interface units and MVP sensors, display basic information and launch applications software to perform operations within that system of sensors.
2. Configuration setup: Create and modify detector configurations to be executed on the MVP sensor and the modular cabinet interface unit.
3. Operation log: Retrieve, display and save field hardware run-time operation logs of special events that have occurred.
4. Streaming video player: Play and record streaming video with flashing detector overlay.
5. Data retrieval: Fetch once or poll for traffic data and alarms and store on PC storage media.
6. Communications server: Provide fault-tolerant, real-time TCP/IP communications to/from all devices and client applications with full logging for systems integration.

The Gridsmart software system shall consist of the following:

1. The latest version of the GRIDSMART Client Software with virtual pan-tilt-zoom functionality. Shall allow the Engineer to configure, view, and manage intersection detection in real time. The system shall be able to automatically email the Engineer reports and alerts.
2. The latest version of the GRIDSMART Performance module which provides counting, classification, turning movements, and signal performance metrics. (GS-3-PFM)

Additional GRIDSMART software modules requested by the City Traffic Engineer may include, but are not limited to the following:

1. Performance Plus module
2. Pedestrian module
3. STREETSMART congestion management technology

Machine Vision Processor (MVP) Sensor

The MVP sensor shall be an integrated imaging color CCD array with zoom lens optics, high-speed, dual-core image processing hardware bundled into a sealed enclosure. The CCD array shall be directly controlled by the dual-core processor,

CITY OF FEDERAL WAY

**21ST AVE S & S 320TH STREET
SIGNALIZATION AND PEDESTRIAN
IMPROVEMENTS PROJECT
PROJECT #36225**

SP-170

CFW SPECIAL PROVISIONS VER. 2023.06

***** PLAN CENTER COPY *** Official bid documents, plan holder's list, and addenda (if applicable) are available on BXWA.com**

thus providing high-quality video for detection that has virtually no noise to degrade detection performance. It shall be possible to zoom the lens as required for setup and operation. It shall provide JPEG video compression as well as standard MPEG-4 digital streaming video with flashing detector overlay. The MVP shall provide direct real-time iris and shutter speed control. The MVP image sensor shall be equipped with an integrated 22x zoom lens that can be changed using configuration computer software. The digital streaming video output and all data communications shall be transmitted over the three-wire power cable.

The MVP sensor shall operate on 110/220 VAC, 50/60Hz at a maximum of 25 watts. The camera and processor electronics shall consume a maximum of 10 watts and the remaining 15 watts shall support an enclosure heater.

Placement of detection zones shall be by means of a PC with a Windows 7, Vista or XP operating system with a keyboard and mouse. The detection zones shall be superimposed on images of the traffic scenes and viewable as such on the PC monitor. The detection zones shall be created by using a mouse to draw the detection zones on the PC monitor. Using the mouse and keyboard it shall be possible to place, size and orient detection zones to provide optimal road coverage for vehicle detection. It shall be possible to download detector configurations from the PC to the MVP sensor and cabinet interface module, to retrieve the detector configuration that is currently running in the MVP sensor and to back up detector configurations by saving them to a PC storage device.

The video detection system shall optimally detect vehicle passage and presence when the MVP sensor is mounted thirty (30) feet or higher above the roadway, when the image sensor is adjacent to the desired coverage area and when the distance to the farthest detection zone locations are not greater than ten (10) times the mounting height of the MVP. The recommended deployment geometry for optimal detection also requires that there be an unobstructed view of each traveled lane where detection is required. Although optimal detection may be obtained when the MVP is mounted directly above the traveled lanes, the MVP shall not be required to be directly over the roadway. The MVP shall be able to view either approaching or receding traffic or both in the same field of view. The preferred MVP sensor orientation shall be to view approaching traffic since there are more high contrast features on vehicles as viewed from the front rather than the rear. The MVP sensor placed at a mounting height that maximizes vehicle image occlusion shall be able to simultaneously monitor a maximum of six (6) traffic lanes when mounted at the road-side or up to eight (8) traffic lanes when mounted in the center with four lanes on each side.

Modular Cabinet Interface Unit

The modular cabinet interface unit shall provide the hardware and software means for up to eight (8) MVP sensors to communicate real-time detection states and alarms to a local traffic signal controller. It shall comply with the electrical and protocol specifications of the detector rack standards. The card shall have 1500 Vrms isolation between rack logic ground and street wiring.

CITY OF FEDERAL WAY

**21ST AVE S & S 320TH STREET
SIGNALIZATION AND PEDESTRIAN
IMPROVEMENTS PROJECT
PROJECT #36225**

SP-171

CFW SPECIAL PROVISIONS VER. 2023.06

***** PLAN CENTER COPY *** Official bid documents, plan holder's list, and addenda (if applicable) are available on BXWA.com**

The modular cabinet interface unit shall be a simple interface card that plugs directly into a NEMA type C or D detector rack. The modular cabinet interface unit shall occupy only two (2) slots of the detector rack. The modular cabinet interface unit shall accept up to sixteen (16) phase inputs and shall provide up to twenty-four (24) detector outputs.

Communications Interface Panel

The communications interface panel shall support up to eight (8) MVP sensors and shall accept 110/220 VAC, 50/60 Hz Power. The communications interface panel shall provide predefined wire termination blocks for MVP sensor power connections, a Broadband-over-Power-Line (BPL) transceiver to support up to 10Mb/s interdevice communications, electrical surge protectors to isolate the modular cabinet interface unit and MVP sensors and an interface connector to cable directly to the modular cabinet interface unit.

The communications interface panel shall provide power for up to eight (8) MVP sensors, taking local line voltage 110/220 VAC, 50/60 Hz and producing 110/220 VAC, 50/60 Hz, at about 30 watts to each MVP sensor. Two 1.25 amp SLO-BLO fuses shall protect the communications interface panel.

Surge Suppressor

An EDCO CX06-BNCY or approved equal transient surge suppressor shall be provided for each MVP sensor.

Installation and Training

The product supplier of the video detection system shall supervise the installation and the testing of the video equipment. A factory certified representative from the manufacturer shall be on-site during installation. The factory representative shall install, make fully operational, and test the system as indicated on the intersection drawings and this specification.

One day of training shall be provided to personnel of the City of Federal Way and King County in the operation, set-up and maintenance of the video detection system. Instruction and materials shall be produced for a maximum of 7 persons and shall be conducted at the City of Federal Way City Hall or King County signal shop.

Warranty

The video detection system shall be warranted against manufacturing defects in materials and workmanship for a period of no less than three (3) years from date of installation. The video detection supplier shall provide all documentation necessary to maintain and operate the system. The supplier shall maintain a program for technical support and software updates following the expiration of the warranty period.

9-29.19 Pedestrian Push Buttons ***(March 22, 2023 CFW GSP)***

Section 9-29.19 is deleted and replaced with the following:

CITY OF FEDERAL WAY

SP-172

**21ST AVE S & S 320TH STREET
SIGNALIZATION AND PEDESTRIAN
IMPROVEMENTS PROJECT
PROJECT #36225**

CFW SPECIAL PROVISIONS VER. 2023.06

***** PLAN CENTER COPY *** Official bid documents, plan holder's list, and addenda (if applicable) are available on BXWA.com**

The Contractor shall provide and install accessible pedestrian pushbuttons and signs, as shown in the Plans. The position of the pedestrian pushbuttons shall be located in a manner such that the tactile arrow is aligned parallel to the direction of travel for the crosswalk which the pushbutton is intended to serve; however final positioning for the optimum effectiveness shall be approved by the Engineer. Accessible Pedestrian Pushbutton units shall be Campbell Company Guardian Model Advisor Guide Accessible Pedestrian Station (AGPS) or approved equal. The station shall have a black body color and white actuator button and shall meet the following requirements:

Pushbuttons shall be mounted to the poles by means of stainless steel bolts. All mountings shall be securely fastened as approved by the Engineer.

The sign legend to be used shall be sign designation R10-3e and shall be nine (9) inches by fifteen (15) inches. All mounting bolts shall be non-corrosive stainless steel.

The pedestrian pushbutton housing shall be aluminum and shall be painted black. Unit(s) shall operate at a temperature range of -35C to 85C. Power requirements shall be 120 VAC, 60 Hz (100 ma, typical +/- 20%).

Pedestrian indicators shall include an audible speaker, call confirmation LED and vibrotactile arrow. The audible speaker shall be programmable to have a button locator tone, acknowledgement tone/message, walk cycle tone/message and clearance tone/message. The unit(s) shall have automatic volume controls for message strength over ambient noise levels. The walk tone/message shall be programmable to stop with the walk signal or other user settable time. The unit(s) shall be user settable for Accessible Pedestrian Signal (APS) message initiation with an extended press or on call.

The call confirmation LED shall be red with 160 degree view ability and once activated shall remain illuminated until the corresponding walk indication is given. An audible acknowledgement message of "WAIT" shall accompany each activation of the call confirmation LED.

The locator tone shall be active for a time of 0.15 seconds or less and shall repeat at 1 second intervals. The locator tone shall be intensity responsive to ambient sound and be audible from six (6) feet to twelve (12) feet from the pushbutton with a maximum of 5 dBA louder than ambient sound.

A walk cycle audible message shall be set for each pushbutton unit and shall be patterned after the model: "Broadway. Walk sign is on to cross Broadway." The walk cycle message shall be intensity responsive to ambient sound with a volume 5 dBA above ambient sound up to a maximum volume of 100 dBA. The walk cycle message shall be audible from the beginning of the associated crosswalk during the walk interval only.

The vibrotactile arrow shall be located on the pushbutton and shall have high visibility contrast of either light on dark or dark on light. The pushbutton units shall

be installed in a manner such that the vibrotactile arrow is aligned parallel to the direction of travel for the crosswalk which the pushbutton is intended to serve. The vibrotactile arrow shall activate with the walk cycle.

9-29.20 Pedestrian Signals
(March 22, 2023 CFW GSP)

Section 9-29.20 is supplemented with the following:

The symbol message modules shall plug directly into the transformer or be solid-state modules.

Side mountings shall be clamshell mountings Type "E," as shown on WSDOT Standard Plan J-20.16 unless otherwise noted in the Plans. All terminal compartments shall be painted in the same manner as specified for signal housings. All pedestrian head mounting bolts shall be noncorrosive stainless steel. Where pedestrian signal heads are to be fastened to the vehicle signal pole, the Contractor shall securely attach the clamshell mounting to the pole using stainless steel Allen-head bolts.

Pedestrian display housings shall have a minimum depth capable of accommodating a Campbell Advisor Pedestrian Pushbutton Controller in the rear of the housing.

Pedestrian signals shall be LED Countdown units as manufactured by Dialite Corporation or approved equal per the specifications included in the appendices of these Special Provisions.

All pedestrian signal displays shall be the light emitting diode (LED) type with displays for "RAISED HAND", "WALKING PERSON" and a countdown timer. Each LED pedestrian signal module shall not require special tools for installation. The installation of an LED pedestrian module shall not require any modification to the housing. Each LED pedestrian module shall be a single, self-contained device, not requiring any on-site assembly for installation into any pedestrian signal housing. The power supply for the LED pedestrian module may be packaged as a separate module.

All pedestrian "RAISED HAND" modules and countdown timer display modules shall be Portland Orange and shall conform to current ITE Standards for size, chromaticity, and intensity. LED pedestrian "RAISED HAND" modules shall be manufactured with a matrix of AlInGaP LED light sources. All pedestrian "WALKING PERSON" modules shall be Lunar White and shall conform to current ITE Standards for size, chromaticity, and intensity. LED pedestrian "WALKING PERSON" modules shall be manufactured with a matrix of InGaN LED light sources. The "RAISED HAND" and "WALKING PERSON" message-bearing surfaces shall be filled (not outline) symbols. The LED pedestrian modules shall be operationally compatible with controller and conflict monitors on this Project.

The LED pedestrian module shall be rated for use in the ambient operating temperature range of minus 40 degrees C to 74 degrees C. Each LED pedestrian module shall be protected against dust and moisture intrusion per the NEMA

CITY OF FEDERAL WAY

**21ST AVE S & S 320TH STREET
SIGNALIZATION AND PEDESTRIAN
IMPROVEMENTS PROJECT
PROJECT #36225**

SP-174

CFW SPECIAL PROVISIONS VER. 2023.06

***** PLAN CENTER COPY *** Official bid documents, plan holder's list, and addenda (if applicable) are available on BXWA.com**

Moisture Resistance STD 250-1991 for Type 4 enclosures to protect all internal components. The assembly, manufacturing, and mounting of the LED pedestrian module shall be designed to assure all internal LED and electronic components are adequately supported to withstand mechanical shock and vibration from high winds and other sources. The manufacturer's name, trademark, serial number, and other necessary identification shall be permanently marked on the backside of the LED pedestrian module. LED signal pedestrian modules used on this Project shall be from the same manufacturer. A label shall be provided on the LED housing, and the Contractor shall mark the label with a permanent marker to note the installation date.

LED pedestrian modules shall operate at a maximum power consumption of 15W. Each LED pedestrian module shall be operated from a 60 plus 3-Hz AC line over a range of 80 VAC to 135 VAC. Nominal operating voltage for all measurements shall be 120 plus 3 volts rms. The LED circuitry shall prevent flicker at less than 100 Hz over the voltage range specified above. Fluctuations in the line voltage specified above shall not affect luminous intensity by more than plus 10 percent. The signal module on-board noise transients and low-repetition high-energy transients shall be as stated in Section 2.1.6, NEMA Standard TS-2, 1992. The individual LED light sources shall be wired so that catastrophic failure of any one LED light source will result in the loss of not more than 20 percent of the signal module light sources. LED pedestrian signal modules shall provide a power factor of 0.90, or greater, when operated at nominal operating voltage, and 25 degrees C. Total harmonic distortion induced into an AC power line by an LED pedestrian module shall not exceed 20 percent. Each LED pedestrian module and associated onboard circuitry shall meet Federal Communications Commission (FCC) Title 47, Subpart B, Section 15 regulations concerning the emission of electrical noise. Two secured, color-coded, 600V, 20AWG minimum, jacketed wires, conforming to the National Electric Code, rated for service at 105 degrees C, are to be provided for electrical connection.

LED signals shall show no evidence of illumination for input voltages below 35 volts. LED signals shall supply illumination current (unregulated) for all input voltages higher than 45 volts (and conform to appropriate intensity requirements specified above 80 volts).

The manufacturer shall provide a written warranty against defects in materials and workmanship for the LED signal modules for a period of 60 months and against loss of intensity below 50 percent of original values for a period of 36 months after installation of the modules. All warranty documentation shall be given to the Engineer prior to installation.

9-29.22 Vacant
(January 8, 2013 CFW GSP)

Section 9-29.22 is deleted and replaced with the following new section:

9-29.22 Battery Backup System

Tesco 22 or approved equivalent battery backup system shall be provided to meet the following requirements:

CITY OF FEDERAL WAY

**21ST AVE S & S 320TH STREET
SIGNALIZATION AND PEDESTRIAN
IMPROVEMENTS PROJECT
PROJECT #36225**

SP-175

Enclosure Specifications

Anodized aluminum weatherproof enclosures shall house BBS and batteries. Enclosures shall be TIG welded construction with welding materials specifically designed for the material to be welded. Enclosures shall have fully framed side hinged outer doors with swaged close tolerance sides for flush fit with drip lip and closed cell neoprene flange compressed gaskets. Front door on each enclosure shall incorporate a full-length piano hinge, pad-lockable draw latch (center area on door-latch side), a keyed Core lock, and a pad lockable welded-in place vandal-proof tab rated at 2000 lbs. There shall be no exposed nut, bolts, screws, rivets or other fasteners on the exterior of the enclosure. Maximum cabinet dimensions shall be 46" H x 20" W x 21.5" D. Maximum weight of main cabinet shall be 250 lbs with batteries. Maximum weight of auxiliary cabinet shall be 425 lbs with batteries. BBS shall be mounted in an interior tilt out housing with 800 lb rated stops. Battery connectors shall be Anderson Connectors with silver plated contacts. Batteries shall be installed in fixed position framed trays for seismic safety and be readily accessible for maintenance. Batteries shall be mounted allowing airflow front and back. Enclosure can include two transfer bypass switches, one for BBS bypass the second for auxiliary generator (optional). All switches must be panel mounted on interior dead front panel board. UV resistant plastic laminated nameplates shall identify all controls and major components. A plastic covered wiring diagram will be attached to the inside of the front door. All components shall be factory wired and conform to required NEMA, NEC, and UL standards. A chassis ground point shall be provided. Panel shall be UL 508 Industrial Control Panel rated.

BBS Panel Minimum Features:

1. System shall provide 700 watts of full control run time for four (4) hours. In addition the system shall provide six (6) to eight (8) hours of flash operation.
2. Auxiliary cabinet shall be provided and shall incorporate twelve (12) additionally supplied batteries.
3. BBS bypass and BBS isolation switch.
4. Deadfront safety panel board with all switches, indicating fuses, plugs, and isolation fuses for each battery pre-wired with phenolic nameplates.
5. All nameplates shall be screwed on phenolic engraved type.
6. All wire terminating lugs shall be full wrap around type.
7. All batteries shall be captive spaced from external captive sides in earthquake proof buckets.
8. Cabinet ventilation shall be by (qty. 2) 4" x 1/4" louvers top and bottom with encapsulated bug screens, cleanable filters and a 100cfm fan to completely exchange air 25 time minimum per minute.
9. All DC terminals and connections shall incorporate safety covers such that the safety covers are in place for every normal maintenance mode.
10. Event Counters & Total Run Time Counter.
11. A red LED indicator light shall be installed on the UPS cabinet facing in the direction of the intersection and viewable from the roadway. The indicator light shall not be installed on the top of the cabinet so as to be visible even during a significant snow event. The indicator light shall be installed in a

CITY OF FEDERAL WAY

**21ST AVE S & S 320TH STREET
SIGNALIZATION AND PEDESTRIAN
IMPROVEMENTS PROJECT
PROJECT #36225**

SP-176

CFW SPECIAL PROVISIONS VER. 2023.06

***** PLAN CENTER COPY *** Official bid documents, plan holder's list, and addenda (if applicable) are available on BXWA.com**

manner to be activated only when the UPS units are operational and powering the intersection.

BBS Unit Minimum Specifications

BBS unit shall provide a true sine-wave output with minimum 1400 Volt-Amp continuous capacity. BBS must provide for utility service isolation when in operation. The minimum rating for wattage output will be 950 watts. The BBS shall be capable of running an intersection with LED lights (for Run Time consult manufacturer). The unit shall operate off-line, with transfer time of 2 ms or less, with battery condition indicator, with automatic test provisions, and with hot-swappable batteries (all batteries in system). BBS will automatically recharge batteries from full discharge to 95% capacity within 6 hours. BBS will provide on-line operation for a minimum input of 92 to 145 VAC, provide full load output of 120VAC – 10% / +4% at 60 Hz +/- 0.05% over a temperature range of -37° C (optional adder) to +74° C and be a UL Approved Design. For Safety and maintenance the BBS shall not exceed 28 pounds. The BBS unit will be delivered with maintenance manuals and schematic diagrams.

BBS Unit Minimum Features

1. 1400VA 950 Watts, with quick make/break connectors and plugs. (Systems requiring hard wiring termination to/from the inverter are unacceptable).
2. Surge energy withstand 480 Joules, 6.5kA
3. Common mode clamping 0 ns < 5ns typical UL 1449
4. Conditioned power – Computer quality
5. Transient lighting protection – 160 Joules
6. Transfer to battery time – 2 ms
7. Retransfer to utility – 2 ms
8. Each battery shall be 24 volts @ 18 AH with heavy duty Anderson plugs and isolated fused (dead front panel mounted 30 amp) connections to the BBS for greater system reliability and ease of maintenance. Series wiring is unacceptable.
9. Fan cooling shall be fused for locked rotor current.
10. Cooling air shall be ducted to cool the front and back of each battery with air space on all four sides and top of battery.
11. BBS covers shall be 60% open on both sides to diminish the environmental effects of extreme temperatures.
12. Includes USB & RS232, DB9 Computer Interface Ports.
13. Low voltage safety design at 24v DC. (Higher voltage DC systems are unacceptable).

BBS Communications Module

All inverter connections shall be made without the use of tools. This includes: A/C-Input, A/C-Output,

Normally-Open, and Normally-Closed programmable contacts.

Smart Slot Relay I/O Module;

Input #1 Turn the BBS on.

Input #2 Turn the BBS off.

Input #3 Start the BBS self-test.

Input #4 Shut down the BBS (when on battery).

CITY OF FEDERAL WAY

**21ST AVE S & S 320TH STREET
SIGNALIZATION AND PEDESTRIAN
IMPROVEMENTS PROJECT
PROJECT #36225**

SP-177

CFW SPECIAL PROVISIONS VER. 2023.06

***** PLAN CENTER COPY *** Official bid documents, plan holder's list, and addenda (if applicable) are available on BXWA.com**

- Output #1 The BBS is on-battery (during a power failure, self-test or run time calibration).
- Output #2 BBS has a low battery – Programmable.
- Output #3 The protected load is not receiving power from the BBS.
- Output #4 Replace the BBS batteries.
- Output #5 The BBS is overloaded.
- Output #6 Any BBS fault or self-test failure.

Batteries

Batteries shall be maintenance-free, type AGM/VRLA (Absorbed Glass Mat / Valve Regulated Lead Acid), such as APC Smart-UPS RMXL or approved equal. Batteries shall be independently pre-wired and individually fused. Batteries shall be furnished with heavy-duty 50 amp rated silver-plated Anderson Connectors. 100 Amp internal fuse by Battery supplier. Batteries shall be lightweight for personnel safety and protection plus ease of installation and maintenance. Batteries with a weight of over 26 lbs are not acceptable.

Enclosure Temperature Compensation

Operating temperature shall be a minimum -37° C to +74° C.

Power System Analyzer and Conflict Resolution Module

The system shall incorporate an integrated Power System Analyzer and Conflict Resolution Module. The Analyzer will evaluate and make limited adjustments to the incoming utility power and will automatically transfer load to the battery back-up power if utility power is lost. When utility power becomes available, the BBS will analyze the power to verify stability and return to normal operation. The system provides automatic BBS failure detection and automatically isolates the failed BBS and locks the unit on to utility power. Once the failure has been corrected, the system will return to the normal operation.

Triple Bypass System For Offline BBS

1. Smart Power Analyzer with Conflict Monitor Isolation and Transfer Module (SPACT).
2. Power Conflict Monitor (PCM): The PCM monitors load bus power available continuously. If load bus power fails for 5ms the PCM will transfer and isolate the BBS and guarantee that commercial power will be locked on.
3. Watchdog Timer – Redundant 5 ms delay and hard transfer to utility power.
4. The outboard Smart Transfer Switch shall not interrupt the normal controller function. Transfer time shall be 2ms.
5. Onboard Smart I/O module will execute lockout of battery backup system upon Smart detection of any inverter BBS fault. If BBS resets itself, it will automatically be available for backup.
6. ON Inverter to timed relay for Full Time control of Output, 0 to 10 hours.

Smart Battery Charger

Shall charge from shut off discharge to 95% fully charged in less than 6 hours. Batteries shall be ambient enclosure compensated to less than 120°. The battery charger shall utilize Smart Cell Technology to extend battery life.

CITY OF FEDERAL WAY

**21ST AVE S & S 320TH STREET
SIGNALIZATION AND PEDESTRIAN
IMPROVEMENTS PROJECT
PROJECT #36225**

SP-178

CFW SPECIAL PROVISIONS VER. 2023.06

Intelligent Battery Management

The system shall regulate under and over voltages without switching to battery.

A Battery Replacement Warning shall automatically perform a self-test every two weeks. This will issue an alert to the user if batteries are degrading before they wear out. Through software, or the push of a button, self-tests may be performed at anytime. The battery charging system shall be microprocessor controlled to precisely charge batteries in less time than legacy BBS systems.

Hot-swappable Battery Replacement

A 60 second, user friendly, hot-swappable battery replacement system shall be provided to save the time and expense of returning the BBS to the factory for battery service and allows safe and easy replacement of batteries while the system is up and running. Replacement battery packs shall be shippable in a reusable box for convenient return of exhausted batteries to a recycling center.

Testing

Manufacturer shall provide a certified test letter for each UPS system certifying that the equipment passed all manufacturer performed testing per national codes and standards.

Warranty

Manufacturers shall provide a two (2) year factory-replacement parts warranty on the BBS. Batteries shall be warranted for full replacement for two (2) years. The warranty shall be included in the total bid price of the BBS.

Included Design Options

1. Automatic transfer switch (ATS) and Generator 30-amp external reverse service plug.
2. Keyed lock (Core or #2 Corbin)
3. Heater with thermostat
4. Two (2) conductor shielded cable to be installed between the signal controller cabinet and the UPS unit to enable signal flash operation following depletion of batteries to established minimum. Ten (10) feet of slack shall be provided within both signal cabinet and UPS cabinet.

9-29.24 Service Cabinets ***(March 22, 2023 CFW GSP)***

Section 9-29.24 is supplemented with the following:

The service cabinet shall be aluminum, and shall conform to Federal Way Drawing Number 3-45 included in the appendices of these Special Provisions. The unit shall be modified as necessary to meet all current requirements of the Department of Labor and Industries and Puget Sound Energy. The service cabinet shall be equipped with a lockable stainless steel handle and a three-point locking system. The service cabinet shall contain one (1) ground fault receptacle. Main breaker, branch breakers, and contactors shall be rated per the Breaker Schedule in the Plans.

CITY OF FEDERAL WAY

**21ST AVE S & S 320TH STREET
SIGNALIZATION AND PEDESTRIAN
IMPROVEMENTS PROJECT
PROJECT #36225**

SP-179

CFW SPECIAL PROVISIONS VER. 2023.06

The service cabinet shall be equipped with a door-in-door, dead-front assembly, which shall prevent the exposure of circuit breakers and wiring. Wiring shall be arranged so that any piece of apparatus may be removed without disconnecting any wiring, except the lead to that piece of apparatus. All wiring shall be appropriately marked with a permanent, indelibly marked, clip-sleeve wire marker. All wiring shall conform to NEMA Class II C.

The service cabinet shall be aluminum, and shall be a Skyline Electric Type ES-2EU or approved equal with Underwriters Laboratory label on the panel boards.

A copy of the wiring diagram shall be provided in a plastic holder mounted conveniently inside the service cabinet. Nameplates shall be provided for each control component and shall be embossed phenolic with white letters on black background. Nameplates shall be screw-fastened.

9-29.25 Amplifier, Transformer, and Terminal Cabinets
(March 22, 2023 CFW GSP)

Section 9-29.25 is supplemented with the following:

Where noted in the Plans, terminal cabinets shall be furnished and installed on mast arm poles. Terminal cabinets shall be mounted at a minimum height of seven (7) feet to maintain ADA accessible pathways.

Numbered terminal strips shall be installed in each cabinet with sufficient connections to accommodate all necessary wires and specs as shown on the Wiring Diagram.

The unit shall be fastened to the pole shaft with a minimum of three (3) self-tapping galvanized metal screws employing minimum 1-inch-diameter flat washers on the inside of the cabinet.

Following installation, an epoxy sealant shall be used to provide a rain tight seal between the pole shaft and the cabinet back.

SECTION 9-34 PAVEMENT MARKING MATERIAL

9-34.2 Paint

9-34.2(5) Low VOC Waterborne Paint
(December 16, 2022 CFW GSP)

Section 9-34.2(5) is replaced with the following:

The City of Federal Way does not allow Low VOC Waterborne Paint.

9-35.5 Portable Changeable Message Signs
(January 10, 2022, WSDOT GSP, Option 1.2023)

Section 9-35.5 is revised to read:

PCMS, mPCMS, and truck mounted PCMS shall meet the requirements of the MUTCD and the following general requirements:

CITY OF FEDERAL WAY

21ST AVE S & S 320TH STREET
SIGNALIZATION AND PEDESTRIAN
IMPROVEMENTS PROJECT
PROJECT #36225

SP-180

CFW SPECIAL PROVISIONS VER. 2023.06

*** PLAN CENTER COPY *** Official bid documents, plan holder's list, and addenda (if applicable) are available on BXWA.com

1. Use light emitting diode (LED) technology capable of emitting a yellow or amber image when displayed with a flat black image matching the background when not activated.
2. Be capable of displaying 3-lines of at least 8 alphanumeric characters with a minimum of one pixel separation between each line.
3. Be capable of displaying 2 phases of messages at 2.0 second display each in addition to 3 phases of messages at 1.5 second display each.
4. PCMS characters shall be at least 18 inches in height.
5. mPCMS characters shall be at least 12 inches in height.
6. Truck-mounted PCMS characters shall be at least 10 inches in height.
7. The sign display shall be covered by a stable, impact resistant polycarbonate face. The sign face shall be non-glare from all angles and shall not degrade due to exposure to ultraviolet light.
8. Be capable of simultaneously activating all pixels for the purpose of pixel diagnostics. This feature shall not occur when the sign is displaying an active message.
9. The light source shall be energized only when the sign is displaying an active message.
10. Primary source of power shall be solar power with a battery backup to provide continuous operation when failure of the primary power source occurs.
11. The sign controller software shall be NTCIP compliant.

The PCMS panels and related equipment shall be permanently mounted on a trailer or truck with all needed controls and power generating equipment.

Standard Plans

(January 9, 2023 WSDOT)

The State of Washington Standard Plans for Road, Bridge and Municipal Construction M21-01, effective September 30, 2022 is made a part of this contract.

The Standard Plans are revised as follows:

A-10.30

RISER RING detail (Including SECTION view and RISER RING DIMENSIONS table): The RISER RING detail is deleted from the plan.

CITY OF FEDERAL WAY

SP-181

**21ST AVE S & S 320TH STREET
SIGNALIZATION AND PEDESTRIAN
IMPROVEMENTS PROJECT
PROJECT #36225**

CFW SPECIAL PROVISIONS VER. 2023.06

***** PLAN CENTER COPY *** Official bid documents, plan holder's list, and addenda (if applicable) are available on BXWA.com**

INSTALLATION detail, SECTION A: The "1/4" callout is revised to read "+/- 1/4" (SEE CONTRACT ~ Note: The + 1/4" installation is shown in the Section A view)"

B-90.40

Valve Detail – DELETED

C-8

DELETED

C-8A

DELETED

C-20.42

Plan View (Case 22A-31), callout, was; "BEAM GUARDRAIL ANCHOR TYPE 10 PAY LIMIT" is revised to read; "BEAM GUARDRAIL ANCHOR TYPE 11 PAY LIMIT"

C-23.60

DELETED

C-23.70

Sheet 1, Detail A, callout, was – "EIGHT 5/8" X 1/2" (IN) BOLTS W/ HEX NUTS AND WASHERS (SEE NOTE 5) "is revised to read: "EIGHT 5/8" X 1-1/2" (IN) BOLTS W/ HEX NUTS AND WASHERS (SEE NOTE 5)".

Sheet 2, ANCHOR RAIL ELEMENT DETAIL and associated Enlarged Detail, 3/4" Diameter hole pattern (8 holes), callout, "3/4" DIAMETER HOLE (TYP.)" is revised to read: "29/32" x 1 1/8" (IN) SLOT (TYP.)"

D-2.04

DELETED

D-2.06

DELETED

D-2.08

DELETED

D-2.32

DELETED

D-2.34

DELETED

D-2.60

DELETED

D-2.62

DELETED

D-2.64

CITY OF FEDERAL WAY

**21ST AVE S & S 320TH STREET
SIGNALIZATION AND PEDESTRIAN
IMPROVEMENTS PROJECT
PROJECT #36225**

SP-182

CFW SPECIAL PROVISIONS VER. 2023.06

***** PLAN CENTER COPY *** Official bid documents, plan holder's list, and addenda (if applicable) are available on BXWA.com**

DELETED

D-2.66

DELETED

D-2.68

DELETED

D-2.80

DELETED

D-2.88

DELETED

D-3.15

DELETED

D-3.16

DELETED

D-3.17

DELETED

D-3.10

Sheet 1, Typical Section, callout – “FOR WALLS WITH SINGLE SLOPE TRAFFIC BARRIER. USE THE DETAILS ABOVE THE MATCH LINE ON STANDARD PLAN D-3.15” is revised to read; “FOR WALLS WITH SINGLE SLOPE TRAFFIC BARRIER, SEE CONTRACT PLANS”

Sheet 1, Typical Section, callout – “FOR WALLS WITH F-SHAPE TRAFFIC BARRIER. USE THE DETAILS ABOVE THE MATCH LINE ON STANDARD PLAN D-3.16” is revised to read; “FOR THE WALLS WITH F-SHAPE TRAFFIC BARRIER, SEE CONTRACT PLANS”

D-3.11

Sheet 1, Typical Section, callout – ““B” BRIDGE APPROACH SLAB (SEE BRIDGE PLANS) OR PERMANENT GEOSYNTHETIC WALL BARRIER ~ SEE STANDARD PLANS D-3.15 OR D-3.16” is revised to read; “B” BARRIER APPROACH SLAB OR MOMENT SLAB (SEE CONTRACT PLANS)

Sheet 1, Typical Section, callout – “TYPICAL BARRIER ON BRIDGE APPROACH SLAB (SEE BRIDGE PLANS) OR PERMANENT GEOSYNTHETIC WALL BARRIER ~ SEE STANDARD PLANS D-3.15 OR D-3.16” is revised to read; “TYPICAL BARRIER ON BRIDGE APPROACH SLAP OR MOMENT SLAB (SEE CONTRACT PLANS)

D-10.10

Wall Type 1 may be used if no traffic barrier is attached on top of the wall. Walls with traffic barriers attached on top of the wall are considered non-standard and shall be designed in accordance with the current WSDOT Bridge Design Manual (BDM) and the revisions stated in the 11/3/15 Bridge Design memorandum.

CITY OF FEDERAL WAY

**21ST AVE S & S 320TH STREET
SIGNALIZATION AND PEDESTRIAN
IMPROVEMENTS PROJECT
PROJECT #36225**

SP-183

CFW SPECIAL PROVISIONS VER. 2023.06

*** PLAN CENTER COPY *** Official bid documents, plan holder's list, and addenda (if applicable) are available on BXWA.com

D-10.15

Wall Type 2 may be used if no traffic barrier is attached on top of the wall. Walls with traffic barriers attached on top of the wall are considered non-standard and shall be designed in accordance with the current WSDOT BDM and the revisions stated in the 11/3/15 Bridge Design memorandum.

D-10.30

Wall Type 5 may be used in all cases.

D-10.35

Wall Type 6 may be used in all cases.

D-10.40

Wall Type 7 may be used if no traffic barrier is attached on top of the wall. Walls with traffic barriers attached on top of the wall are considered non-standard and shall be designed in accordance with the current WSDOT BDM and the revisions stated in the 11/3/15 Bridge Design memorandum.

D-10.45

Wall Type 8 may be used if no traffic barrier is attached on top of the wall. Walls with traffic barriers attached on top of the wall are considered non-standard and shall be designed in accordance with the current WSDOT BDM and the revisions stated in the revisions stated in the 11/3/15 Bridge Design memorandum.

D-15.10

STD Plans D-15 series "Traffic Barrier Details for Reinforced Concrete Retaining Walls" are withdrawn. Special designs in accordance with the current WSDOT BDM are required in place of these STD Plans.

D-15.20

STD Plans D-15 series "Traffic Barrier Details for Reinforced Concrete Retaining Walls" are withdrawn. Special designs in accordance with the current WSDOT BDM are required in place of these STD Plans.

D-15.30

STD Plans D-15 series "Traffic Barrier Details for Reinforced Concrete Retaining Walls" are withdrawn. Special designs in accordance with the current WSDOT BDM are required in place of these STD Plans.

F-10.18

Note 2, "Region Traffic engineer approval is needed to install a truck apron lower than 3".
- DELETED

J-10.10

Sheet 4 of 6, "Foundation Size Reference Table", PAD WIDTH column, Type 33xD=6' – 3" is revised to read: 7' – 3". Type 342LX / NEMA P44=5' – 10" is revised to read: 6' – 10"
Sheet 5 of 6, Plan View, "FOR EXAMPLE PAD SHOWN HERE:", "first bullet" item, "-SPACE BETWEEN TYPE B MOD. CABINET AND 33x CABINET IS 6" (IN)" IS REVISED TO

CITY OF FEDERAL WAY

**21ST AVE S & S 320TH STREET
SIGNALIZATION AND PEDESTRIAN
IMPROVEMENTS PROJECT
PROJECT #36225**

SP-184

CFW SPECIAL PROVISIONS VER. 2023.06

*** PLAN CENTER COPY *** Official bid documents, plan holder's list, and addenda (if applicable) are available on BXWA.com

READ: "SPACE BETWEEN TYPE B MOD. CABINET (BACK OF ALL CHANNEL STEEL) AND 33x CABINET IS 6" (IN) (CHANNEL STEEL ADDS ABOUT 5" (IN))"

J-10.16

Key Note 1, Standard Plan J-10.30 revised to Standard Plan J-10.14

J-10.17

Key Note 1, Standard Plan J-10.30 revised to Standard Plan J-10.14

J-10.18

Key Note 1, Standard Plan J-10.30 revised to Standard Plan J-10.14

J-20.10

Elevation View, horizontal dimension to edge of sidewalk 1" (IN) OR LESS DESIRABLE ~ 18" (IN) MAXIMUM is revised to read: "10" (IN) MAXIMUM"

J-20.26

Add Note 1, "1. One accessible pedestrian pushbutton station per pedestrian pushbutton post."

J-20.16

View A, callout, was – LOCK NIPPLE, is revised to read; CHASE NIPPLE

J-21.10

Sheet 1, Elevation View, Round Concrete Foundation Detail, callout – "ANCHOR BOLTS ~ 3/4" (IN) x 30" (IN) FULL THREAD ~ THREE REQ'D. PER ASSEMBLY" IS REVISED TO READ: "ANCHOR BOLTS ~ 3/4" (IN) x 30" (IN) FULL THREAD ~ FOUR REQ'D. PER ASSEMBLY"

Sheet 1 of 2, Elevation view (Round), add dimension depicting the distance from the top of the foundation to find 2 #4 reinforcing bar shown, to read; 3" CLR.. Delete "(TYP.)" from the 2 1/2" CLR. dimension, depicting the distance from the bottom of the foundation to find 2 # 4 reinf. Bar.

Sheet 1 of 2, Elevation view (Square), add dimension depicting the distance from the top of the foundation to find 1 #4 reinforcing bar shown, to read; 3" CLR. Delete "(TYP.)" from the 2 1/2" CLR. dimension, depicting the distance from the bottom of the foundation to find 1 # 4 reinf. Bar.

Sheet 2 of 2, Elevation view (Round), add dimension depicting the distance from the top of the foundation to find 2 #4 reinforcing bar shown, to read; 3" CLR. Delete "(TYP.)" from the 2 1/2" CLR. dimension, depicting the distance from the bottom of the foundation to find 2 # 4 reinf. Bar.

Sheet 2 of 2, Elevation view (Square), add dimension depicting the distance from the top of the foundation to find 1 #4 reinforcing bar shown, to read; 3" CLR. Delete "(TYP.)" from the 2 1/2" CLR. dimension, depicting the distance from the bottom of the foundation to find 1 # 4 reinf. Bar.

Detail F, callout, "Heavy Hex Clamping Bolt (TYP.) ~ 3/4" (IN) Diam. Torque Clamping Bolts (see Note 3)" is revised to read; "Heavy Hex Clamping Bolt (TYP.) ~ 3/4" (IN) Diam. Torque Clamping Bolts (see Note 1)"

Detail F, callout, "3/4" (IN) x 2' – 6" Anchor Bolt (TYP.) ~ Four Required (See Note 4)" is revised to read; "3/4" (IN) x 2' – 6" Anchor Bolt (TYP.) ~ Three Required (See Note 2)"

CITY OF FEDERAL WAY

**21ST AVE S & S 320TH STREET
SIGNALIZATION AND PEDESTRIAN
IMPROVEMENTS PROJECT
PROJECT #36225**

SP-185

CFW SPECIAL PROVISIONS VER. 2023.06

*** PLAN CENTER COPY *** Official bid documents, plan holder's list, and addenda (if applicable) are available on BXWA.com

J-21.15

Partial View, callout, was – LOCK NIPPLE ~ 1 ½” DIAM., is revised to read; CHASE NIPPLE ~ 1 ½” (IN) DIAM.

J-21.16

Detail A, callout, was – LOCKNIPPLE, is revised to read; CHASE NIPPLE

J-22.15

Ramp Meter Signal Standard, elevation, dimension 4’ - 6” is revised to read; 6’-0” (2x) Detail A, callout, was – LOCK NIPPLE ~ 1 ½” DIAM. is revised to read; CHASE NIPPLE ~ 1 ½” (IN) DIAM.

J-40.10

Sheet 2 of 2, Detail F, callout, “12 – 13 x 1 ½” S.S. PENTA HEAD BOLT AND 12” S. S. FLAT WASHER” is revised to read; “12 – 13 x 1 ½” S.S. PENTA HEAD BOLT AND 1/2” (IN) S. S. FLAT WASHER”

J-40.36

Note 1, second sentence: “Finish shall be # 2B for backbox and # 4 for the cover.” Is revised to read: “Finish shall be # 2B for barrier box and HRAP (Hot Rolled Annealed and Pickled) for the cover.

J-40.37

Note 1, second sentence: “Finish shall be # 2B for backbox and # 4 for the cover.” Is revised to read: “Finish shall be # 2B for barrier box and HRAP (Hot Rolled Annealed and Pickled) for the cover.

J-75.20

Key Notes, note 16, second bullet point, was: “1/2” (IN) x 0.45” (IN) Stainless Steel Bands”, add the following to the end of the note: “Alternate: Stainless steel cable with stainless steel ends, nuts, bolts, and washers may be used in place of stainless steel bands and associated hardware.”

J-75.41

DELETED

J-75.55

Notes, Note A1, Revise reference, was – G-90.29, should be -G-90.20.

K-80.20

DELETED

L-5.10

Sheet 2, Typical Elevation, callout – “2’ – 0” MIN. LAP SPLICE BETWEEN (mark) A #3 BAR AND WALL REINFORCEMENT ~ TYPICAL” is revised to read: “2’ – 0” MIN. LAP SPLICE BETWEEN (MARK) A #4 BAR AND WALL REINFORCEMENT ~ TYPICAL”

Section C, callout; “(mark) A #3 is revised to read: “(mark) A #4”, callout – “(mark) B #3” is revised to read: “(mark) B #4”, callout – “(mark) C #3 TIE” is revised to read: “(mark) C #4 TIE”

Reinforcing Steel Bending Diagram, (mark) B detail, callout – “128 deg.” is revised to read: “123 deg.”, callout – “51 deg.” is revised to read: “57 deg.”

The following are the Standard Plan numbers applicable at the time this project was advertised. The date shown with each plan number is the publication approval date shown in the lower right-hand corner of that plan. Standard Plans showing different dates shall not be used in this contract.

A-10.10-00.....8/7/07	A-30.35-00.....10/12/07	A-50.10-01.....8/17/21
A-10.20-00.....10/5/07	A-40.00-01.....7/6/22	A-50.40-01.....8/17/21
A-10.30-00.....10/5/07	A-40.10-04.....7/31/19	A-60.10-03.....12/23/14
A-20.10-00.....8/31/07	A-40.15-00.....8/11/09	A-60.20-03.....12/23/14
A-30.10-00.....11/8/07	A-40.20-04.....1/18/17	A-60.30-01.....6/28/18
A-30.30-01.....6/16/11	A-40.50-02.....12/23/14	A-60.40-00.....8/31/07
B-5.20-03.....9/9/20	B-30.50-03.....2/27/18	B-75.20-03.....8/17/21
B-5.40-02.....1/26/17	B-30.60-00.....9/9/20	B-75.50-01.....6/10/08
B-5.60-02.....1/26/17	B-30.70-04.....2/27/18	B-75.60-00.....6/8/06
B-10.20-02.....3/2/18	B-30.80-01.....2/27/18	B-80.20-00.....6/8/06
B-10.40-02.....8/17/21	B-30.90-02.....1/26/17	B-80.40-00.....6/1/06
B-10.70-02.....8/17/21	B-35.20-00.....6/8/06	B-85.10-01.....6/10/08
B-15.20-01.....2/7/12	B-35.40-00.....6/8/06	B-85.20-00.....6/1/06
B-15.40-01.....2/7/12	B-40.20-00.....6/1/06	B-85.30-00.....6/1/06
B-15.60-02.....1/26/17	B-40.40-02.....1/26/17	B-85.40-00.....6/8/06
B-20.20-02.....3/16/12	B-45.20-01.....7/11/17	B-85.50-01.....6/10/08
B-20.40-04.....2/27/18	B-45.40-01.....7/21/17	B-90.10-00.....6/8/06
B-20.60-03.....3/15/12	B-50.20-00.....6/1/06	B-90.20-00.....6/8/06
B-25.20-02.....2/27/18	B-55.20-03.....8/17/21	B-90.30-00.....6/8/06
B-25.60-02.....2/27/18	B-60.20-02.....9/9/20	B-90.40-01.....1/26/17
B-30.05-00.....9/9/20	B-60.40-01.....2/27/18	B-90.50-00.....6/8/06
B-30.10-03.....2/27/18	B-65.20-01.....4/26/12	B-95.20-02.....8/17/21
B-30.15-00.....2/27/18	B-65.40-00.....6/1/06	B-95.40-01.....6/28/18
B-30.20-04.....2/27/18	B-70.20-00.....3/15/22	
B-30.30-03.....2/27/18	B-70.60-01.....1/26/17	
B-30.40-03.....2/27/18		
C-1.....9/8/22	C-22.40-09.....9/8/22	C-60.70-01.....9/8/22
C-1b.....9/8/22	C-22.45-06.....9/8/22	C-60.80-01.....9/8/22
C-1d.....10/31/03	C-23.70-00.....8/22/22	C-70.15-00.....8/17/21
C-2c.....8/12/19	C-24.10-03.....7/24/22	C-70.10-03.....8/17/21
C-4f.....8/12/19	C-24.15-00.....3/15/22	C-75.10-02.....9/16/20
C-6a.....9/8/22	C-25.20-07.....8/20/21	C-75.20-03.....8/20/21
C-7.....9/8/22	C-25.22-06.....8/20/21	C-75.30-03.....8/21/20
C-7a.....9/8/22	C-25.26-05.....8/20/21	C-80.10-02.....9/16/20
C-20.10-08.....9/8/22	C-25.30-01.....8/20/21	C-80.20-01.....6/11/14

CITY OF FEDERAL WAY

**21ST AVE S & S 320TH STREET
SIGNALIZATION AND PEDESTRIAN
IMPROVEMENTS PROJECT
PROJECT #36225**

SP-187

CFW SPECIAL PROVISIONS VER. 2023.06

*** PLAN CENTER COPY *** Official bid documents, plan holder's list, and addenda (if applicable) are available on BXWA.com

C-20.14-05.....9/8/22	C-25.80-05.....8/12/19	C-80.30-02.....8/20/21
C-20.15-02.....6/11/14	C-60.10-02.....9/8/22	C-80.40-01.....6/11/14
C-20.18-04.....9/8/22	C-60.15-00.....8/17/21	C-85.10-00.....4/8/12
C-20.40-09.....9/8/22	C-60.20-01.....9/8/22	C-85.11-01.....9/16/20
C-20.41-04.....8/22/22	C-60.30-01.....8/17/21	C-85.15-02.....8/27/21
C-20.42-05.....7/14/15	C-60.40-00.....8/17/21	C-85.18-03.....9/8/22
C-20.43-00.....8/22/22	C-60.45-00.....8/17/21	
C-20.45.03.....9/8/22	C-60.50-00.....8/17/21	
C-22.16-07.....9/16/20	C-60.60-00.....8/17/21	
D-2.36-03.....6/11/14	D-4.....12/11/98	D-10.35-00.....7/8/08
D-2.46-02.....8/13/21	D-6.....6/19/98	D-10.40-01.....12/2/08
D-2.84-00.....11/10/05	D-10.10-01.....12/2/08	D-10.45-01.....12/2/08
D-2.92-01.....4/26/22	D-10.15-01.....12/2/08	
D-3.09-00.....5/17/12	D-10.20-01.....8/7/19	
D-3.10-01.....5/29/13	D-10.25-01.....8/7/19	
D-3.11-03.....6/11/14	D-10.30-00.....7/8/08	
E-1.....2/21/07	E-4.....8/27/03	
E-2.....5/29/98	E-4a.....8/27/03	
F-10.12-04.....9/24/20	F-10.62-02.....4/22/14	F-40.15-04.....9/25/20
F-10.16-00.....12/20/06	F-10.64-03.....4/22/14	F-40.16-03.....6/29/16
F-10.18-03.....3/28/22	F-30.10-04.....9/25/20	F-45.10-03.....8/13/21
F-10.40-04.....9/24/20	F-40.12-03.....6/29/16	F-80.10-04.....7/15/16
F-10.42-00.....1/23/07	F-40.14-03.....6/29/16	
G-10.10-00.....9/20/07	G-26.10-00.....7/31/19	
G-20.10-03.....8/20/21	G-30.10-04.....6/23/15	
G-22.10-04.....6/28/18	G-50.10-03.....6/28/18	
G-24.10-00.....11/8/07	G-90.10-03.....7/11/17	
G-24.20-01.....2/7/12	G-90.20-05.....7/11/17	
G-24.30-02.....6/28/18	G-90.30-04.....7/11/17	
G-24.40-07.....6/28/18	G-95.10-02.....6/28/18	
G-24.50-05.....8/7/19	G-95.20-03.....6/28/18	
G-24.60-05.....6/28/18	G-95.30-03.....6/28/18	
G-25.10-05.....9/16/20		
H-10.10-00.....7/3/08	H-32.10-00.....9/20/07	H-70.10-02.....8/17/21
H-10.15-00.....7/3/08	H-60.10-01.....7/3/08	H-70.20-02.....8/17/21
H-30.10-00.....10/12/07	H-60.20-01.....7/3/08	
I-10.10-01.....8/11/09	I-30.20-00.....9/20/07	I-40.20-00.....9/20/07
I-30.10-02.....3/22/13	I-30.30-02.....6/12/19	I-50.20-01.....6/10/13
I-30.15-02.....3/22/13	I-30.40-02.....6/12/19	I-60.10-01.....6/10/13
I-30.16-01.....7/11/19	I-30.60-02.....6/12/19	I-60.20-01.....6/10/13
I-30.17-01.....6/12/19	I-40.10-00.....9/20/07	I-80.10-02.....7/15/16
J-05.50-00.....8/30/22	J-28.10-02.....8/7/19	J-50.25-00.....6/3/11

CITY OF FEDERAL WAY

**21ST AVE S & S 320TH STREET
SIGNALIZATION AND PEDESTRIAN
IMPROVEMENTS PROJECT
PROJECT #36225**

SP-188

CFW SPECIAL PROVISIONS VER. 2023.06

*** PLAN CENTER COPY *** Official bid documents, plan holder's list, and addenda (if applicable) are available on BXWA.com

J-10.....7/18/97	J-28.22-00.....8/07/07	J-50.30-00.....6/3/11
J-10.10-04.....9/16/20	J-28.24-02.....9/16/20	J-60.05-01.....7/21/16
J-10.12-00.....9/16/20	J-28.26-01.....12/02/08	J-60.11-00.....5/20/13
J-10.14-00.....9/16/20	J-28.30-03.....6/11/14	J-60.12-00.....5/20/13
J-10.15-01.....6/11/14	J-28.40-02.....6/11/14	J-60.13-00.....6/16/10
J-10.16-02.....8/18/21	J-28.42-01.....6/11/14	J-60.14-01.....7/31/19
J-10.17-02.....8/18/21	J-28.43-01.....6/28/18	J-75.10-02.....7/10/15
J-10.18-02.....8/18/21	J-28.45-03.....7/21/16	J-75.20-01.....7/10/15
J-10.20-04.....8/18/21	J-28.50-03.....7/21/16	J-75.30-02.....7/10/15
J-10.21-02.....8/18/21	J-28.60-03.....8/27/21	J-75.50-00.....8/30/22
J-10.22-02.....8/18/21	J-28.70-04.....8/30/22	J-75.55-00.....8/30/22
J-10.25-00.....7/11/17	J-29.10-02.....8/26/22	J-80.05-00.....8/30/22
J-10.26-00.....8/30/22	J-29.15-01.....7/21/16	J-80.10-01.....8/18/21
J-12.15-00.....6/28/18	J-29.16-02.....7/21/16	J-80.12-00.....8/18/21
J-12.16-00.....6/28/18	J-30.10-01.....8/26/22	J-80.15-00.....6/28/18
J-15.10-01.....6/11/14	J-40.01-00.....8/30/22	J-81.10-02.....8/18/21
J-15.15-02.....7/10/15	J-40.05-00.....7/21/16	J-81.12-00.....9/3/21
J-20.01-00.....8/30/22	J-40.10-04.....4/28/16	J-84.05-00.....8/30/22
J-20.10-04.....7/31/19	J-40.20-03.....4/28/16	J-86.10-00.....6/28/18
J-20.11-03.....7/31/19	J-40.30-04.....4/28/16	J-90.10-03.....6/28/18
J-20.15-03.....6/30/14	J-40.35-01.....5/29/13	J-90.20-03.....6/28/18
J-20.16-02.....6/30/14	J-40.36-02.....7/21/17	J-90.21-02.....6/28/18
J-20.20-02.....5/20/13	J-40.37-02.....7/21/17	J-90.50-00.....6/28/18
J-20.26-01.....7/12/12	J-40.38-01.....5/20/13	
J-21.10-04.....6/30/14	J-40.39-00.....5/20/13	
J-21.15-01.....6/10/13	J-40.40-02.....7/31/19	
J-21.16-01.....6/10/13	J-45.36-00.....7/21/17	
J-21.17-01.....6/10/13	J-50.05-00.....7/21/17	
J-21.20-01.....6/10/13	J-50.10-01.....7/31/19	
J-22.15-02.....7/10/15	J-50.11-02.....7/31/19	
J-22.16-03.....7/10/15	J-50.12-02.....8/7/19	
J-26.10-03.....7/21/16	J-50.13-01.....8/30/22	
J-26.15-01.....5/17/12	J-50.15-01.....7/21/17	
J-26.20-01.....6/28/18	J-50.16-01.....3/22/13	
J-27.10-01.....7/21/16	J-50.18-00.....8/7/19	
J-27.15-00.....3/15/12	J-50.19-00.....8/7/19	
J-28.01-00.....8/30/22	J-50.20-00.....6/3/11	
K-70.20-01.....6/1/16	K-80.32-00.....8/17/21	K-80.35-01.....9/16/20
K-80.10-02.....9/25/20	K-80.34-00.....8/17/21	K-80.37-01.....9/16/20
L-5.10-00.....9/19/22	L-20.10-03.....7/14/15	L-40.20-02.....6/21/12
L-5.15-00.....9/19/22	L-30.10-02.....6/11/14	L-70.10-01.....5/21/08
L-10.10-02.....6/21/12	L-40.15-01.....6/16/11	L-70.20-01.....5/21/08
M-1.20-04.....9/25/20	M-11.10-04.....8/2/22	M-40.20-00...10/12/07
M-1.40-03.....9/25/20	M-12.10-03.....8/2/22	M-40.30-01.....7/11/17
M-1.60-03.....9/25/20	M-15.10-01.....2/6/07	M-40.40-00.....9/20/07

CITY OF FEDERAL WAY

**21ST AVE S & S 320TH STREET
SIGNALIZATION AND PEDESTRIAN
IMPROVEMENTS PROJECT
PROJECT #36225**

SP-189

CFW SPECIAL PROVISIONS VER. 2023.06

*** PLAN CENTER COPY *** Official bid documents, plan holder's list, and addenda (if applicable) are available on BXWA.com

M-1.80-03.....6/3/11
M-2.20-03.....7/10/15
M-2.21-00.....7/10/15
M-3.10-04.....9/25/20
M-3.20-04.....8/2/22
M-3.30-04.....9/25/20
M-3.40-04.....9/25/20
M-3.50-03.....9/25/20
M-5.10-03.....9/25/20
M-7.50-01.....1/30/07
M-9.50-02.....6/24/14
M-9.60-00.....2/10/09

M-17.10-02.....7/3/08
M-20.10-04.....8/2/22
M-20.20-02.....4/20/15
M-20.30-04.....2/29/16
M-20.40-03.....6/24/14
M-20.50-02.....6/3/11
M-24.20-02.....4/20/15
M-24.40-02.....4/20/15
M-24.60-04.....6/24/14
M-24.65-00.....7/11/17
M-24.66-00.....7/11/17
M-40.10-03.....6/24/14

M-40.50-00.....9/20/07
M-40.60-00.....9/20/07
M-60.10-01.....6/3/11
M-60.20-03.....8/17/21
M-65.10-03.....8/17/21
M-80.10-01.....6/3/11
M-80.20-00.....6/10/08
M-80.30-00.....6/10/08

END DIVISION 9

CITY OF FEDERAL WAY

21ST AVE S & S 320TH STREET
SIGNALIZATION AND PEDESTRIAN
IMPROVEMENTS PROJECT
PROJECT #36225

SP-190

CFW SPECIAL PROVISIONS VER. 2023.06

*** PLAN CENTER COPY *** Official bid documents, plan holder's list, and addenda (if applicable) are available on BXWA.com

STANDARD PLANS AND DETAILS

CITY OF FEDERAL WAY

S. 320th STREET/21ST AVENUE S.
SIGNAL UPGRADES
PROJECT #36225

CROSS SECTION TYPE B

4 LANES + HOV
+ MEDIAN

S. 320TH ST.
IN CITY CENTER

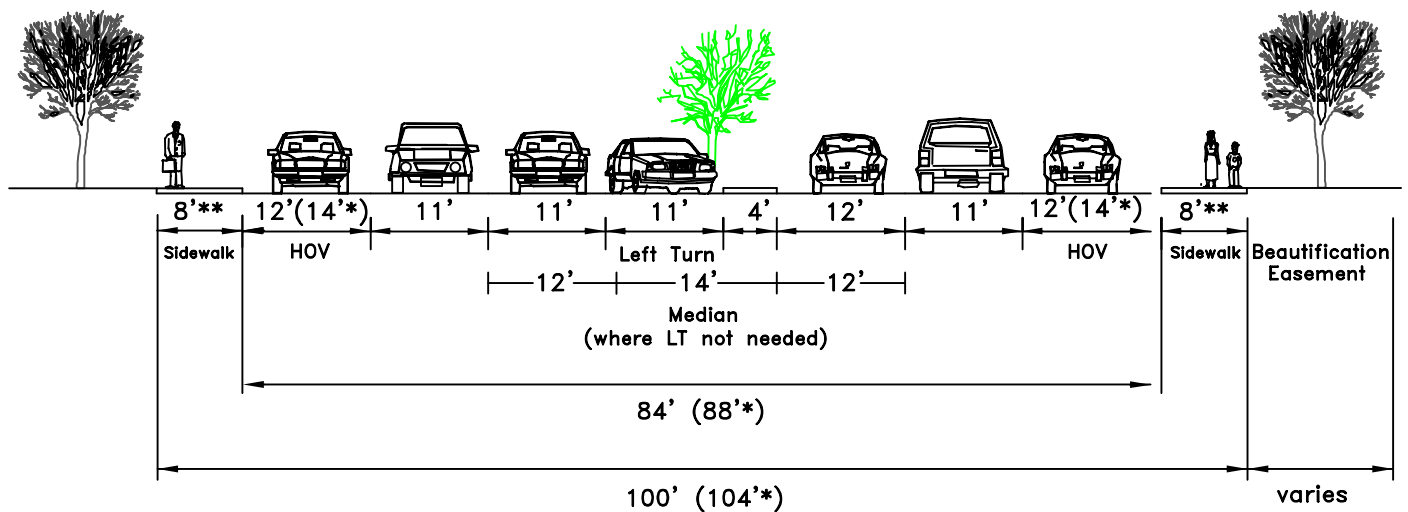

MINIMUM PAVEMENT SECTION

PRINCIPAL

1.0' HMA 1/2", PG 58H-22

0.85' CSTC

SUBBASE: SEE NOTE 1

NOTES:

1. BANK RUN – THICKNESS TO BE DETERMINED BY DESIGN.
2. USE DECORATIVE PEDESTRIAN LIGHTS IN CITY CENTER. SEE STANDARD DETAILS 3-42 & 3-43.
3. USE STANDARD DETAILS 3-30, 3-30A, 3-31, & 3-32 FOR STREET TREES AND STREET LIGHTS.

* ON STATE HIGHWAYS WSDOT REQUIRES OUTSIDE HOV LANES TO BE 14 FEET.

** SIDEWALK DIMENSION IS MEASURED FROM THE BACK OF WALK TO THE FACE OF CURB.

REV: MAR 2019

NOTES:

1. AN EXPANSION JOINT CONSISTING OF 3/8" PRE-MOLDED JOINT MATERIAL SHALL BE PLACED FULL DEPTH AROUND HYDRANTS, POLES, POSTS, AND UTILITY CASTINGS. SEE DETAIL AT RIGHT.
2. AN EXPANSION JOINT CONSISTING OF 3/8" PRE-MOLDED JOINT MATERIAL SHALL BE PLACED IN THE UPPER 2 INCHES OF CURBS AND SIDEWALKS AT 10 FOOT INTERVALS AND AT SIDES OF DRAINAGE INLETS. (JOINT MATERIAL OF 2 1/2" DEPTH MAY BE USED IN LIEU OF 2" DEPTH).
3. EXPANSION JOINTS IN SIDEWALK SHALL BE LOCATED SO AS TO MATCH THE JOINTS IN THE CURB AND GUTTER, WHETHER THE SIDEWALK IS ADJACENT TO THE CURB OR SEPARATED BY A PLANTER STRIP.
4. TOOL MARKS, CONSISTING OF 1/4-INCH 'V'-GROOVES SHALL BE MADE IN THE SIDEWALK AT 5 FOOT INTERVALS, INTERMEDIATE TO THE EXPANSION JOINTS.
5. AN EXPANSION JOINT CONSISTING OF 3/8" PRE-MOLDED JOINT MATERIAL SHALL BE PLACED FULL-DEPTH BETWEEN THE CURB AND ADJACENT SIDEWALK.
6. EXPANSION JOINT MATERIAL SHALL CONFORM TO THE REQUIREMENTS OF ASTM D1751 (AASHTO M 213).
7. MONOLITHIC POURS OF CURB AND SIDEWALK ARE NOT ALLOWED.
8. ALL UTILITY APPURTENANCES WITHIN THE SIDEWALK SHALL HAVE ADA-COMPLIANT NON-SLID LIDS.

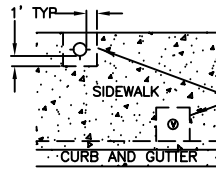
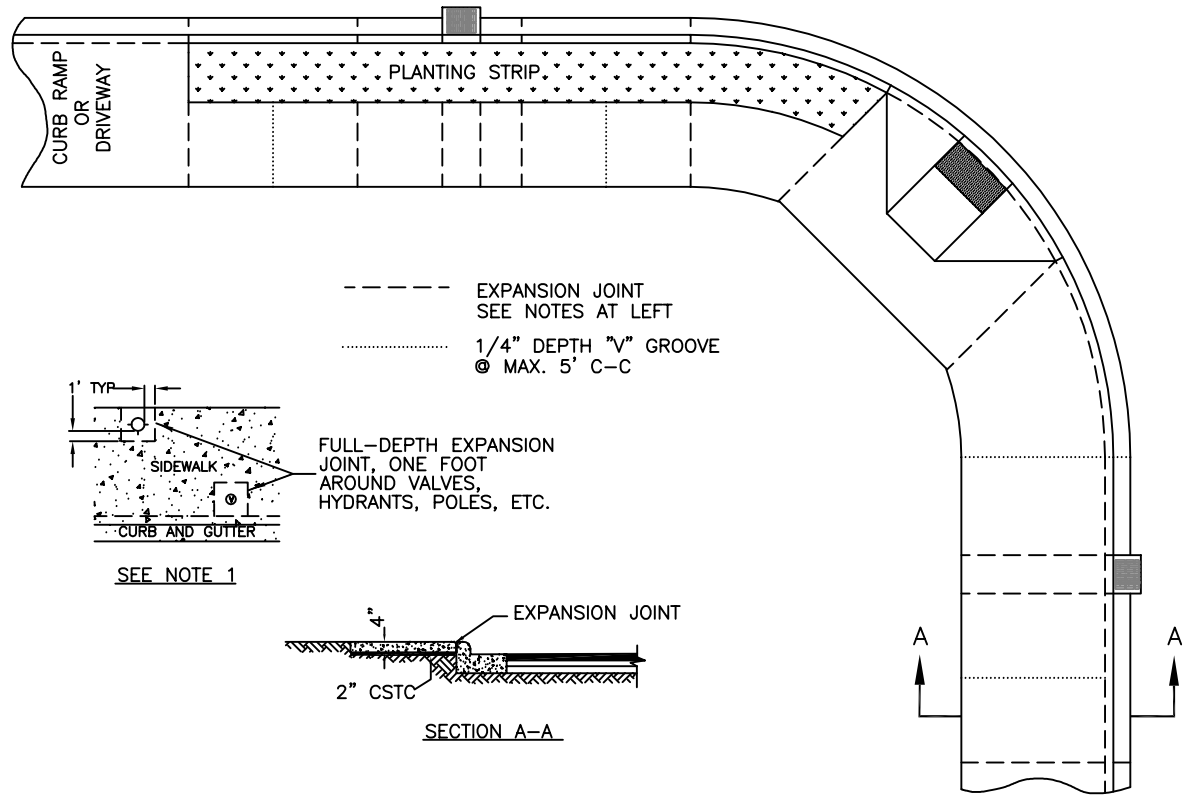

SEE NOTE 1

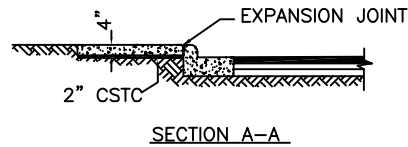

SECTION A-A

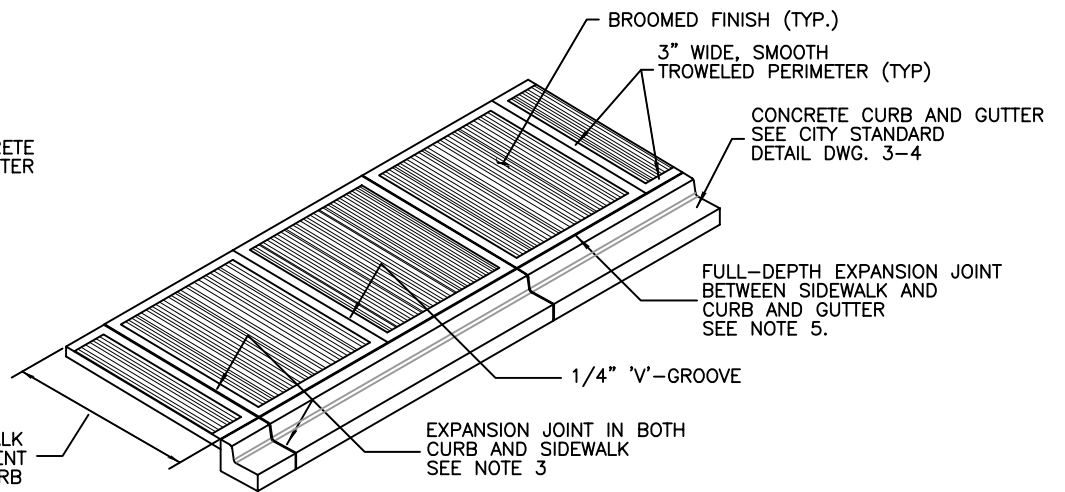
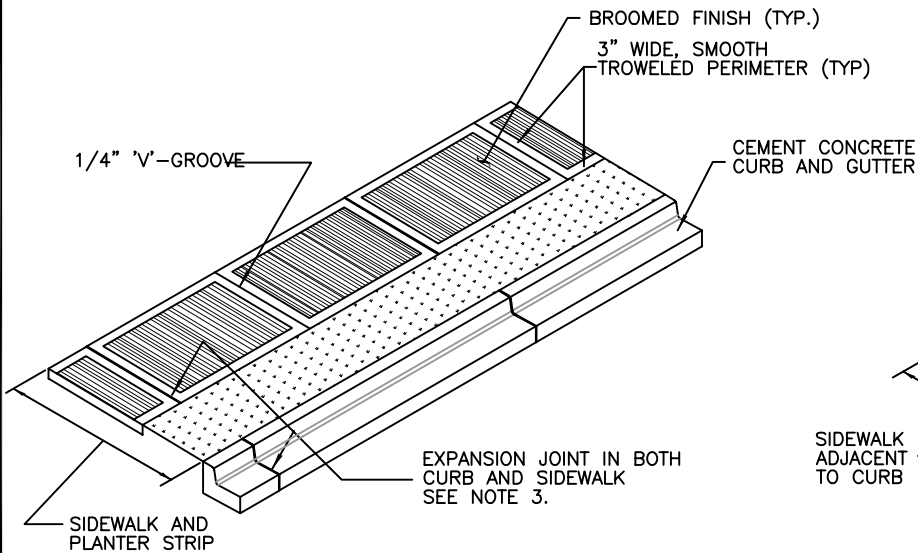

REV JAN 2019

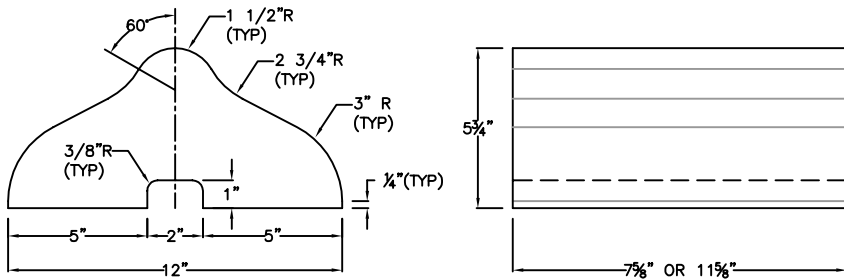

SECTION

ELEVATION

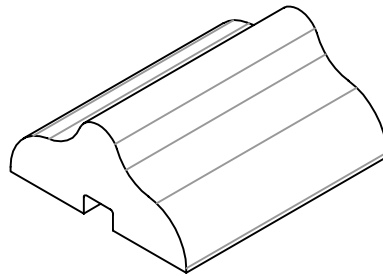

ISOMETRIC

TYPE 'C' BLOCK TRAFFIC CURB

NOTES:

1. SEE DWG. 3-3 FOR JOINT REQUIREMENTS.
2. ROLL GUTTER TO MATCH POSITIVE SUPERELEVATION.
3. TO BE USED ONLY AS APPROVED BY THE PUBLIC WORKS DEPT.

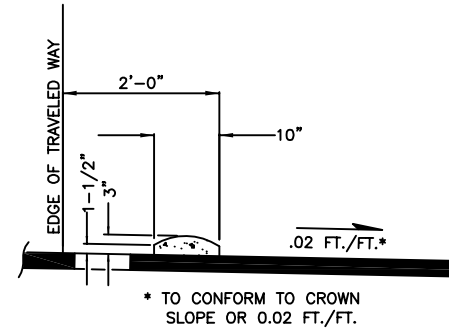

MOUNTABLE CEMENT CONCRETE CURB³

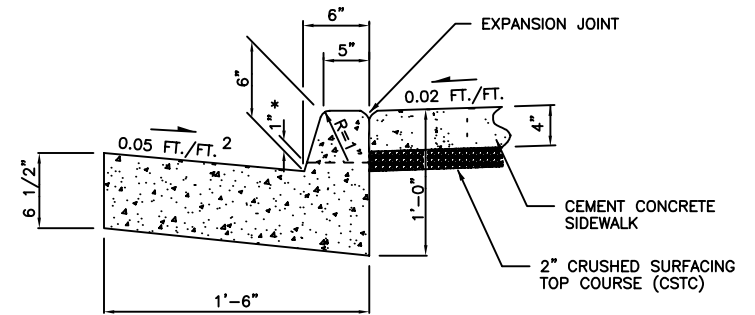

NEW CEMENT CONCRETE CURB & GUTTER

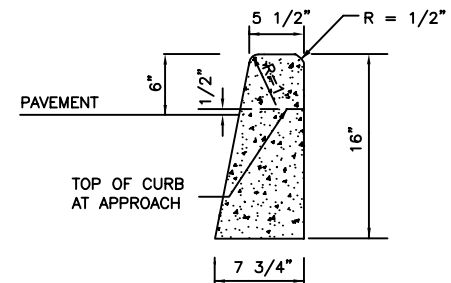

CEMENT CONCRETE BARRIER CURB

REV: FEB 2011

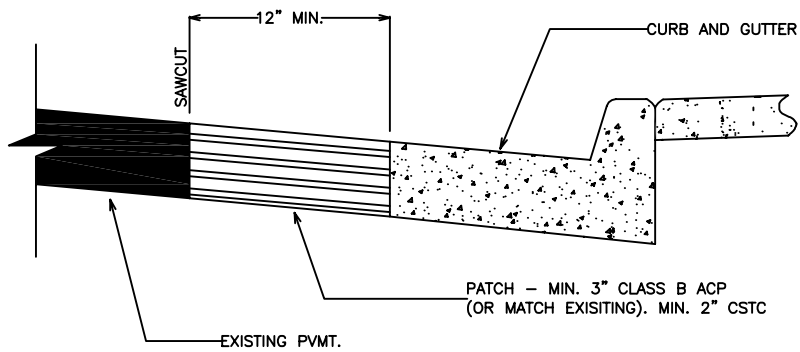

CEMENT CONCRETE CURB & GUTTER REPLACEMENT¹

NOTES:

- EXISTING CURB REPLACEMENT WILL REQUIRE REMOVAL OF ASPHALT A MINIMUM OF 12" FROM FACE OF GUTTER.

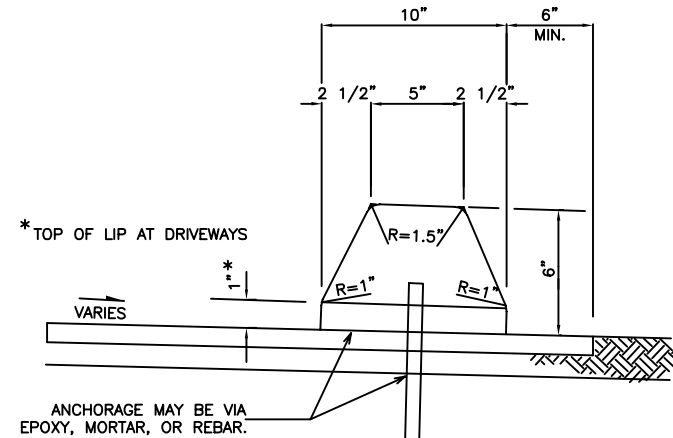

EXTRUDED ASPHALT OR CEMENT CONCRETE CURB
IN PRIVATE PARKING AREAS ONLY

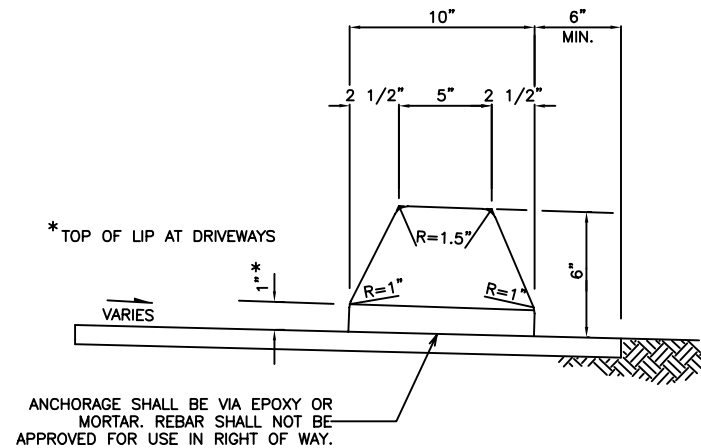

EXTRUDED CEMENT CONCRETE CURB
FOR USE IN PUBLIC RIGHT OF WAY

APRIL 2012

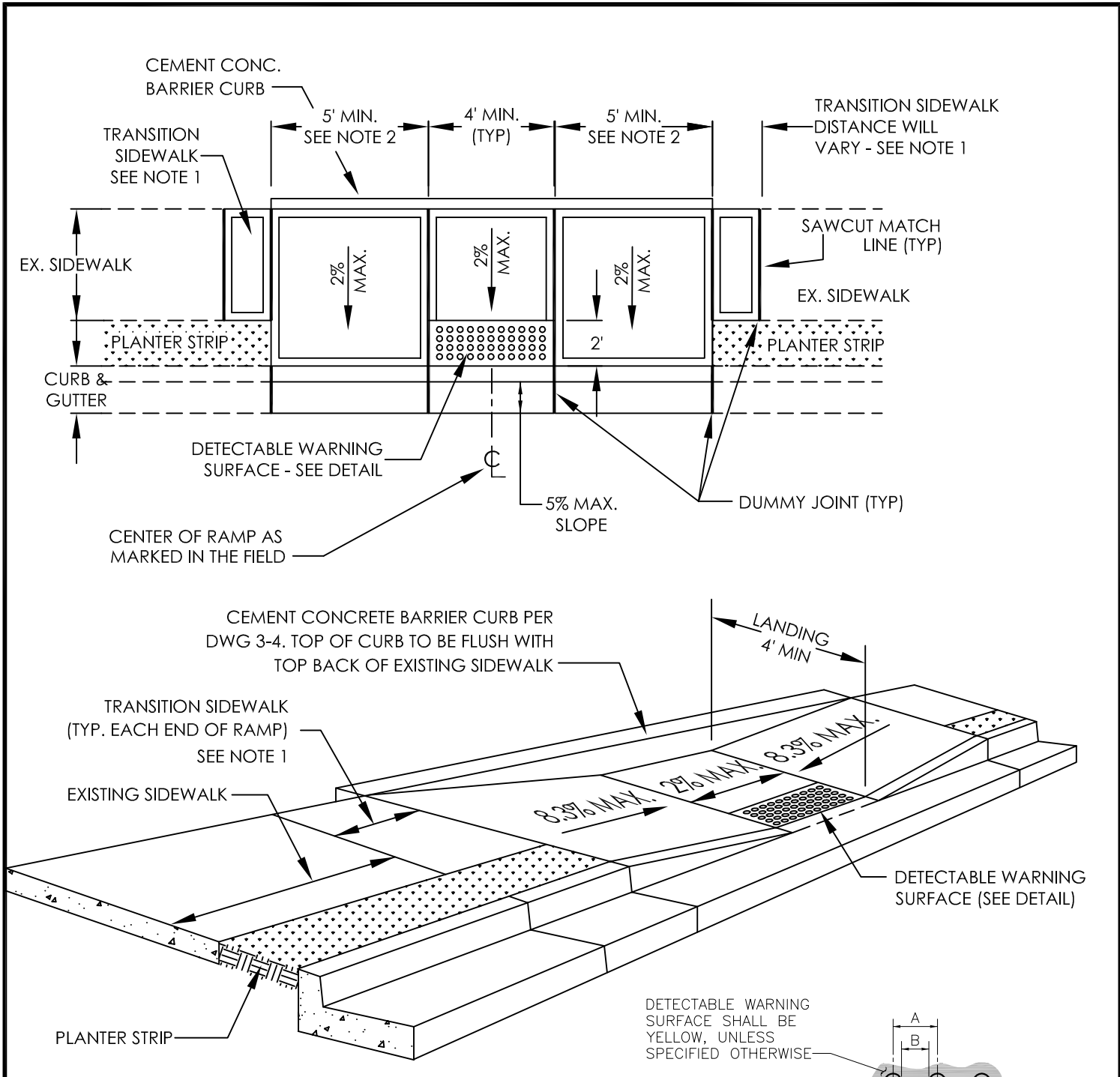

CEMENT CONCRETE BARRIER CURB PER DWG 3-4. TOP OF CURB TO BE FLUSH WITH TOP BACK OF EXISTING SIDEWALK

- NOTES:**
1. THE LENGTH OF THE TRANSITION SIDEWALK SECTION SHALL BE EQUAL TO 1 FOOT MULTIPLIED BY THE DIFFERENCE BETWEEN THE CROSS-SLOPE PERCENTAGE OF THE NEW AND EXISTING PANELS. (I.E., EXISTING PANEL CROSS-SLOPE IS 4% AND NEW PANEL CROSS-SLOPE IS 2% FOR A DIFFERENCE OF 2. 2 MULTIPLIED BY 1 FOOT = 2 FOOT TRANSITION SECTION). IF THE NEW AND EXISTING CROSS-SLOPES ARE EQUAL, THEN THE TRANSITION SECTION IS NOT NEEDED.
 2. LENGTH SHALL BE: 5 FEET (MIN.) AND UP TO 8.3%; OR 'X' FEET @ 8.3% (WHERE 'X' IS EQUAL TO THE LENGTH REQUIRED TO ACHIEVE 8.3% MAXIMUM SLOPE), BUT NOT TO EXCEED 15 FEET IN LENGTH.

DETECTABLE WARNING SURFACE SHALL BE YELLOW, UNLESS SPECIFIED OTHERWISE

	MIN.	MAX.
A	1.60"	2.40"
B	0.65"	-
C	0.45"	0.90"
D	0.90"	1.40"
E	0.20"	0.20"

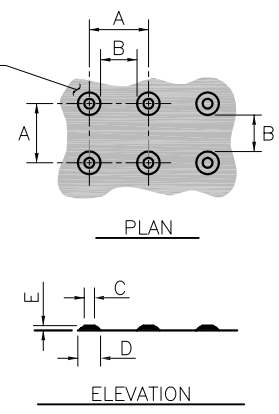

DETECTABLE WARNING SURFACE DETAIL

MAR 2017

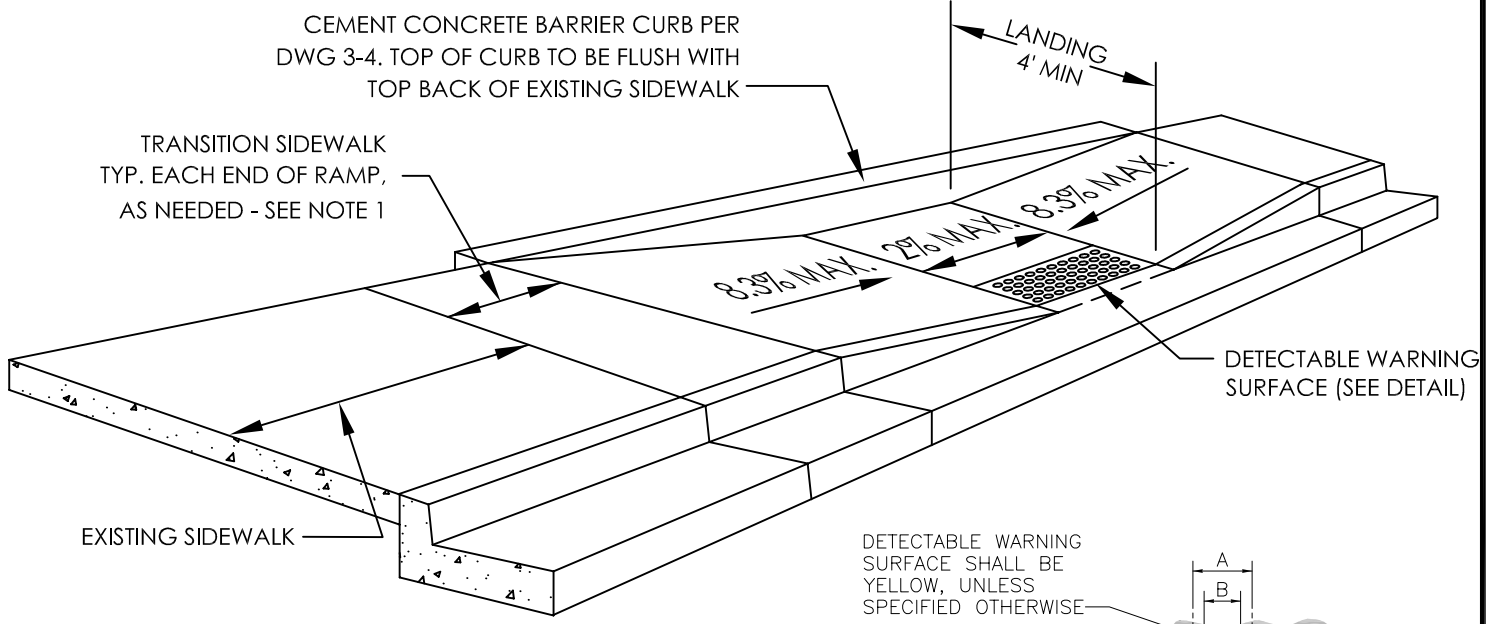
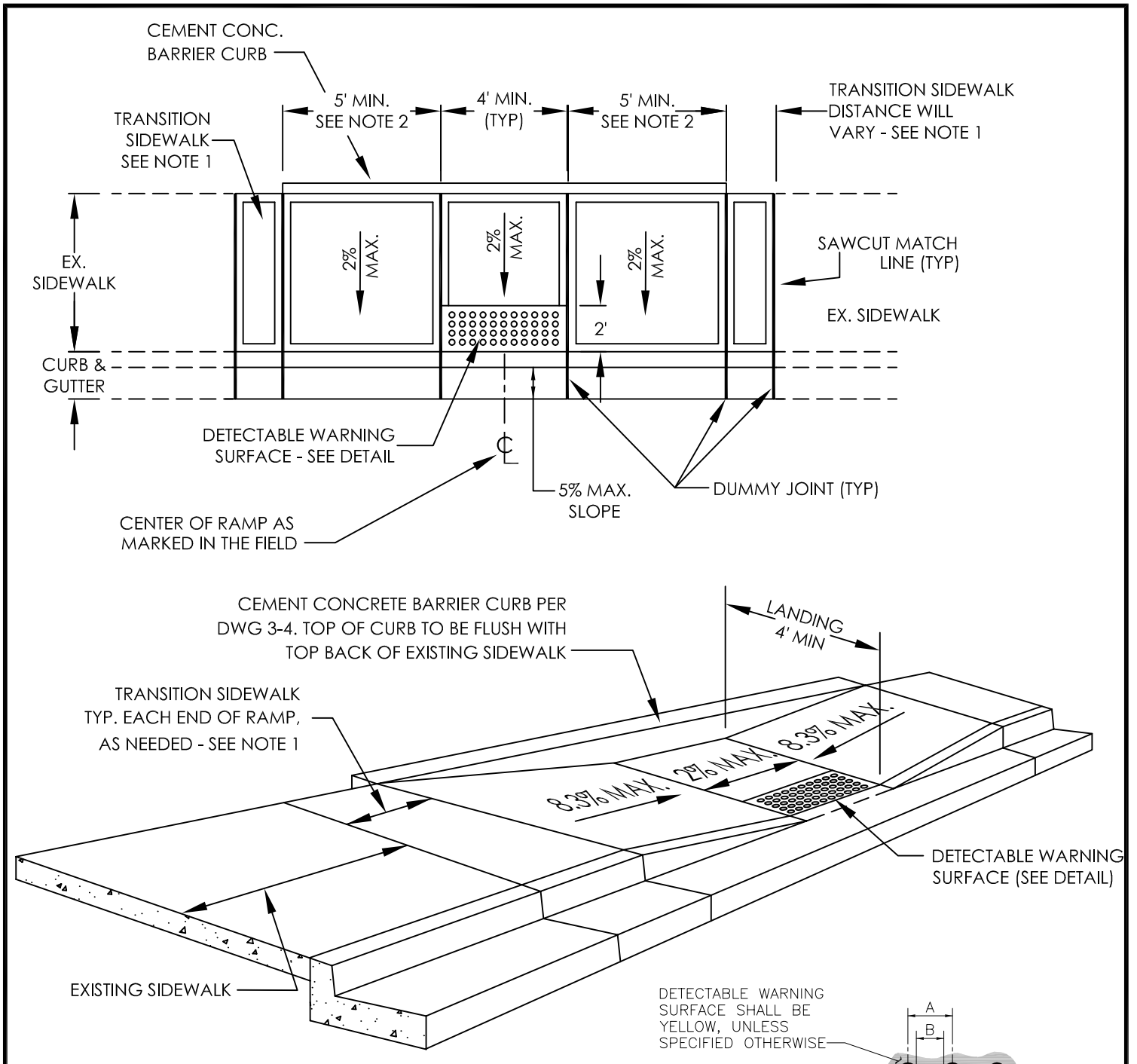

NOTES:

1. THE LENGTH OF THE TRANSITION SIDEWALK SECTION SHALL BE EQUAL TO 1 FOOT MULTIPLIED BY THE DIFFERENCE BETWEEN THE CROSS-SLOPE PERCENTAGE OF THE NEW AND EXISTING PANELS. (I.E., EXISTING PANEL CROSS-SLOPE IS 4% AND NEW PANEL CROSS-SLOPE IS 2% FOR A DIFFERENCE OF 2. 2 MULTIPLIED BY 1 FOOT = 2 FOOT TRANSITION SECTION). IF THE NEW AND EXISTING CROSS-SLOPES ARE EQUAL, THEN THE TRANSITION SECTION IS NOT NEEDED.
2. LENGTH SHALL BE: 5 FEET (MIN.) AND UP TO 8.3%; OR 'X' FEET @ 8.3% (WHERE 'X' IS EQUAL TO THE LENGTH REQUIRED TO ACHIEVE 8.3% MAXIMUM SLOPE), BUT NOT TO EXCEED 15 FEET IN LENGTH.

DETECTABLE WARNING SURFACE SHALL BE YELLOW, UNLESS SPECIFIED OTHERWISE

	MIN.	MAX.
A	1.60"	2.40"
B	0.65"	-
C	0.45"	0.90"
D	0.90"	1.40"
E	0.20"	0.20"

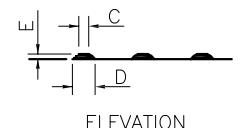
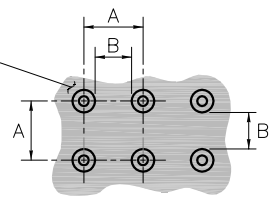

DETECTABLE WARNING SURFACE DETAIL

MAR 2017

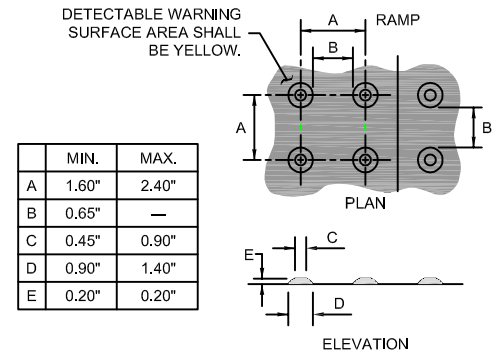
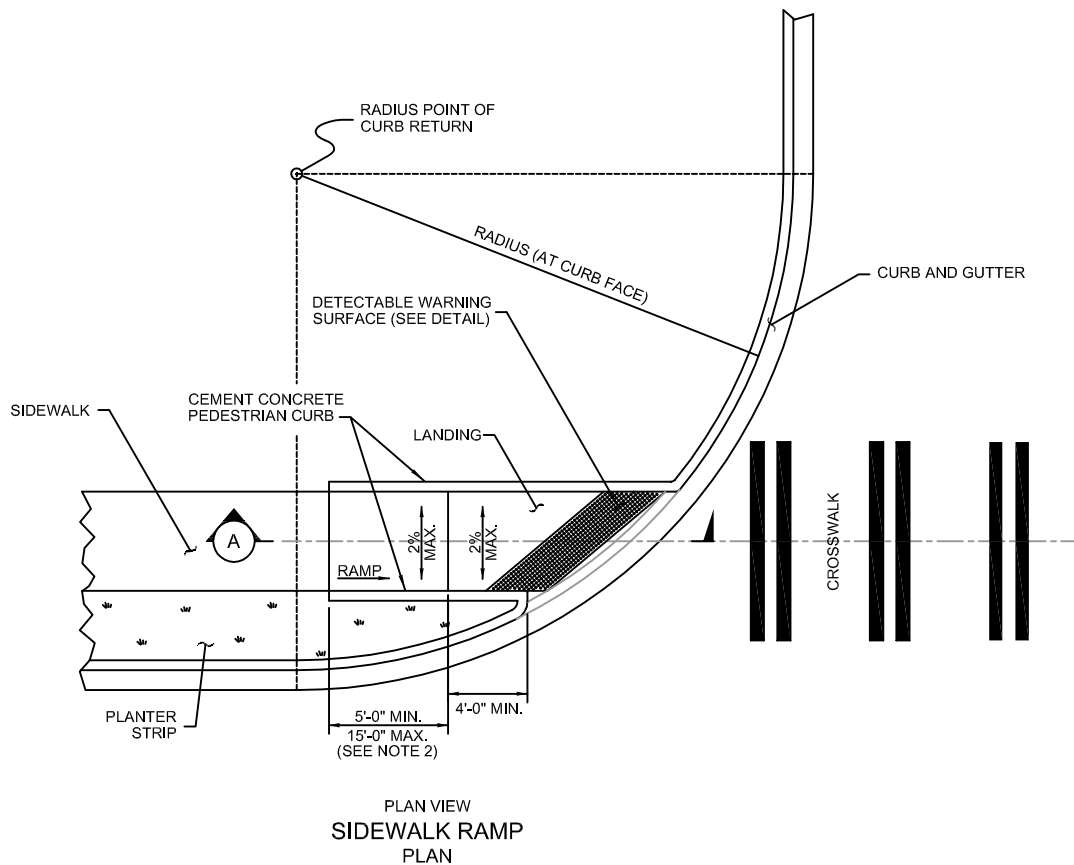

TRUNCATED DOMES
DETECTABLE WARNING
SURFACE DETAIL

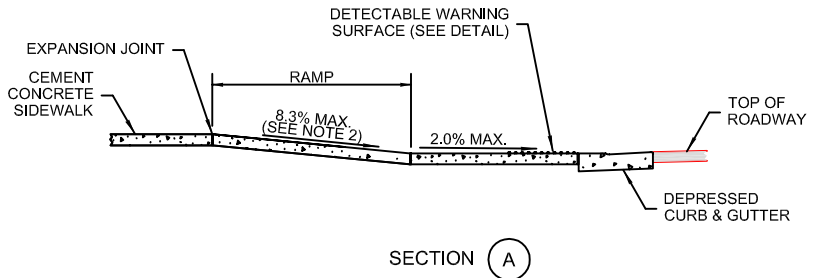
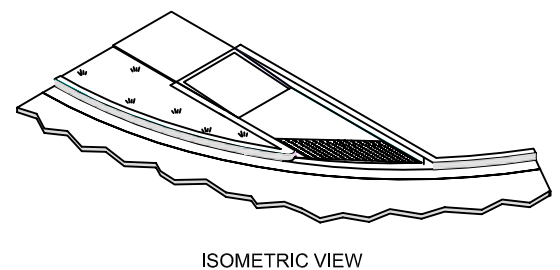

NOTES:

- DO NOT PLACE GRATINGS, JUNCTION BOXES, ACCESS COVERS OR OTHER APPURTANENCES IN FRONT OF THE RAMP OR ON ANY PART OF THE CURB RAMP OR LANDING.
- THE CURB RAMP MAXIMUM RUNNING SLOPE SHALL NOT REQUIRE THE RAMP LENGTH TO EXCEED 15 FEET TO AVOID CHASING THE SLOPE INDEFINITELY WHEN CONNECTING TO STEEP SLOPES. WHEN APPLYING THE 15 FOOT MAX. LENGTH, THE RUNNING SLOPE OF THE CURB RAMP SHALL BE AS FLAT AS FEASIBLE.

REV. JAN 2013

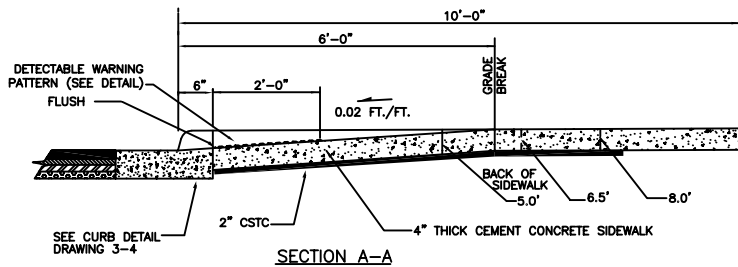
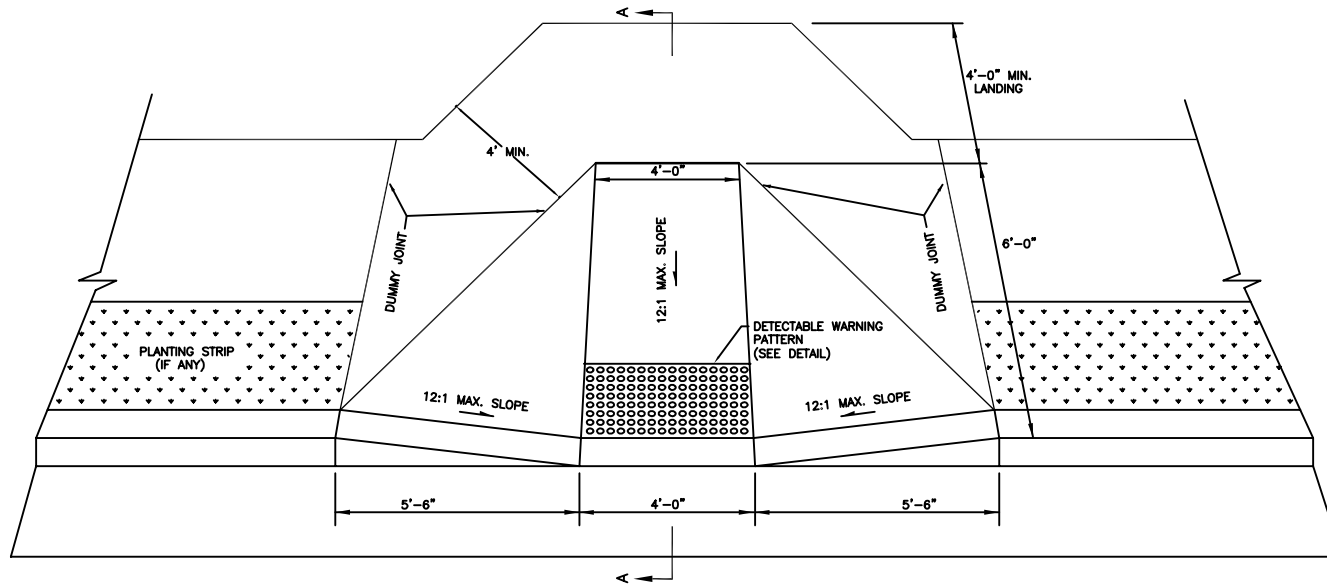

DETECTABLE WARNING PATTERN AREA SHALL BE YELLOW, IN COMPLIANCE WITH WSDOT STD. SPEC. 8-14.3(3)

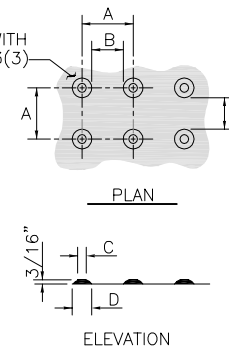

	MIN.	MAX.
A	1 5/8"	2 3/8"
B	5/8"	1 1/2"
C	7/16"	3/4"
D	7/8"	1 7/16"

NOTES:

- RAMP AND APPROACHES SHALL BE CLEAR OF OBSTACLES INCL. HYDRANTS, POLES, AND INLETS.
- RAMP CENTER LINE SHALL BE PERPENDICULAR TO OR RADIAL TO CURB RETURNS UNLESS OTHERWISE APPROVED BY ENGINEER.
- WHEN RAMPS ARE CONSTRUCTED ON ONE SIDE OF THE STREET, RAMPS SHALL BE CONSTRUCTED AT CORRESPONDING SIDEWALK LOCATIONS ON OPPOSITE SIDE OF STREET. SEE DWG. NO. 3-9.
- ON ARTERIAL STREETS, IN GENERAL CASE, CURB RAMPS SHALL BE CONSTRUCTED TWO PER RADIUS, IN OR PREFERABLY ADJACENT TO THE MAIN PEDESTRIAN PATHS.
- ON RESIDENTIAL STREETS OR WHERE UTILITIES ARE IN CONFLICT OR STREET GRADE EXCEEDS 4.0% CURB RAMPS MAY BE CONSTRUCTED ONE PER RADIUS, AT MIDPOINT OF CURB RETURN OR AT MAIN PEDESTRIAN PATH.

REV. MAR 2011

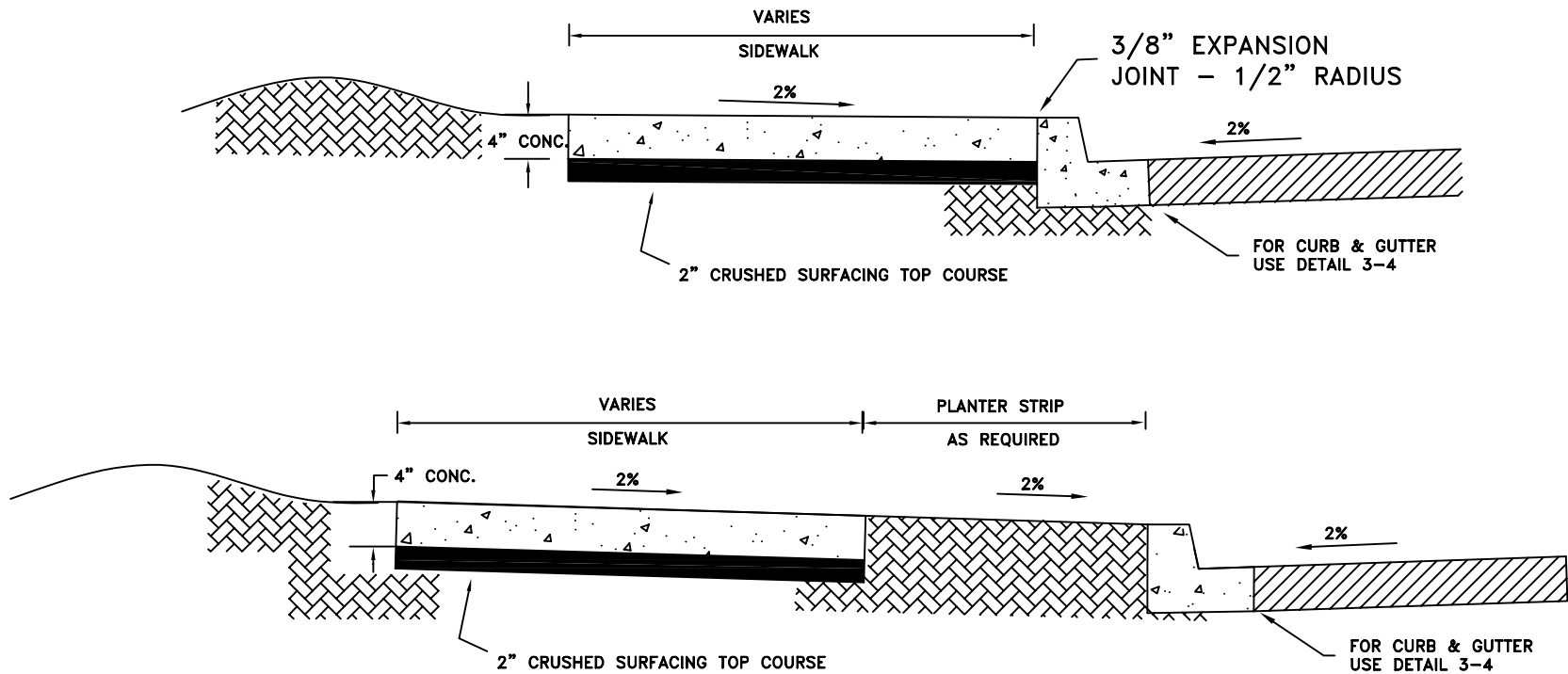

NOTES:

1. FOR JOINTS AND SCORING, SEE FEDERAL WAY STANDARD FOR SIDEWALK SPACING, EXPANSION JOINTS, AND SCORE MARKS.
2. SEE DETAILS 3-6, 3-6A, & 3-7 FOR MINIMUM DEPTH OF CONCRETE THROUGH DRIVEWAY SECTIONS.
3. WHEN CHECKED WITH A 10 FOOT STRAIGHTEDGE, GRADE SHALL NOT DEVIATE MORE THAN 1/8 INCH AND ALIGNMENT SHALL NOT VARY MORE THAN 1/4 INCH.
4. CONCRETE SHALL BE CLASS 3000, WSDOT SPEC. 8-14.

REV. MAR 2011

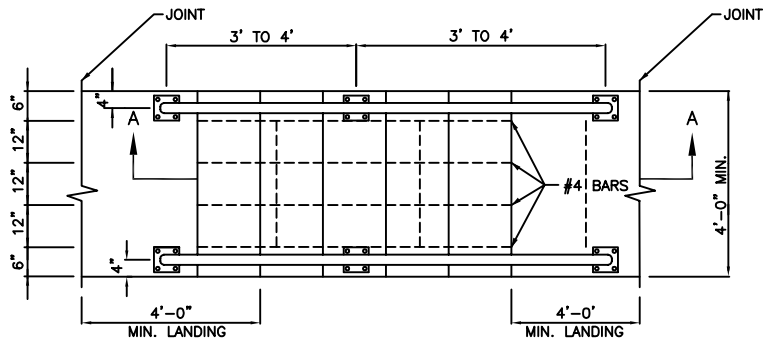

CONCRETE STEPS
PLAN

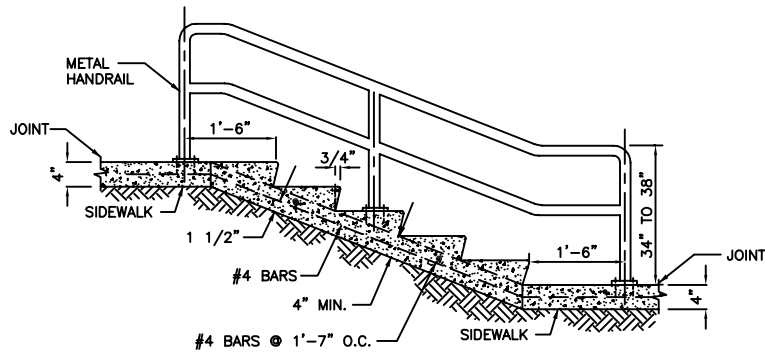

CONCRETE STEPS
SECTION A-A

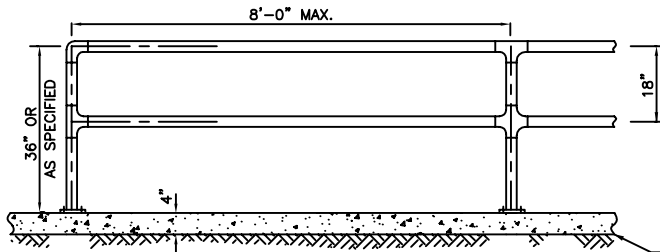

METAL HANDRAIL

CEMENT CONCRETE
SIDEWALK

NOTES FOR CONCRETE STEPS:

1. CONCRETE: CEMENT CONCRETE CLASS 3000.
2. ALL STEPS: SAME DIMENSIONS, WITHIN 3/8" MAX. DIFFERENCE.
3. RISERS: 7" MAX., 5" MIN.
4. TREADS: 12" MAX., 11" MIN., WITH TRANSVERSE 0.01 FT./FT. SLOPE.
5. METAL HANDRAIL REQUIRED FOR ALL STAIRWAYS, REGARDLESS OF THE NUMBER OF STEPS. SEE NOTES BELOW.
6. REINFORCING BARS SHALL MEET THE REQUIREMENTS OF ASTM A-615, GRADE 60 AND ARE REQUIRED FOR 4 STEPS OR MORE.
7. MAX. VERTICAL DISTANCE BETWEEN LANDINGS IS 12'.

NOTES FOR HANDRAILS:

1. GALVANIZED STEEL OR ALUMINUM (40 GAUGE MIN).
2. 2" O.D. ROUND PIPE.
3. WELDED, WITH SMOOTH SURFACE AND JOINTS.
4. TOP OF GRIPPING SURFACE MUST BE BETWEEN 34" AND 38" ABOVE SIDEWALK.
5. BOLT ALL HANDRAILS TO SIDEWALK WITH 4-BOLT SQUARE WELDED PLATES AS SHOWN.

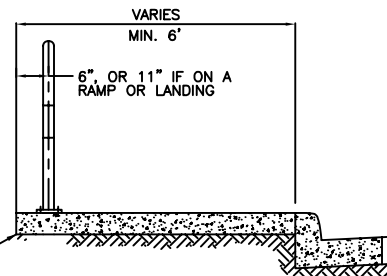

REV. FEB 2017

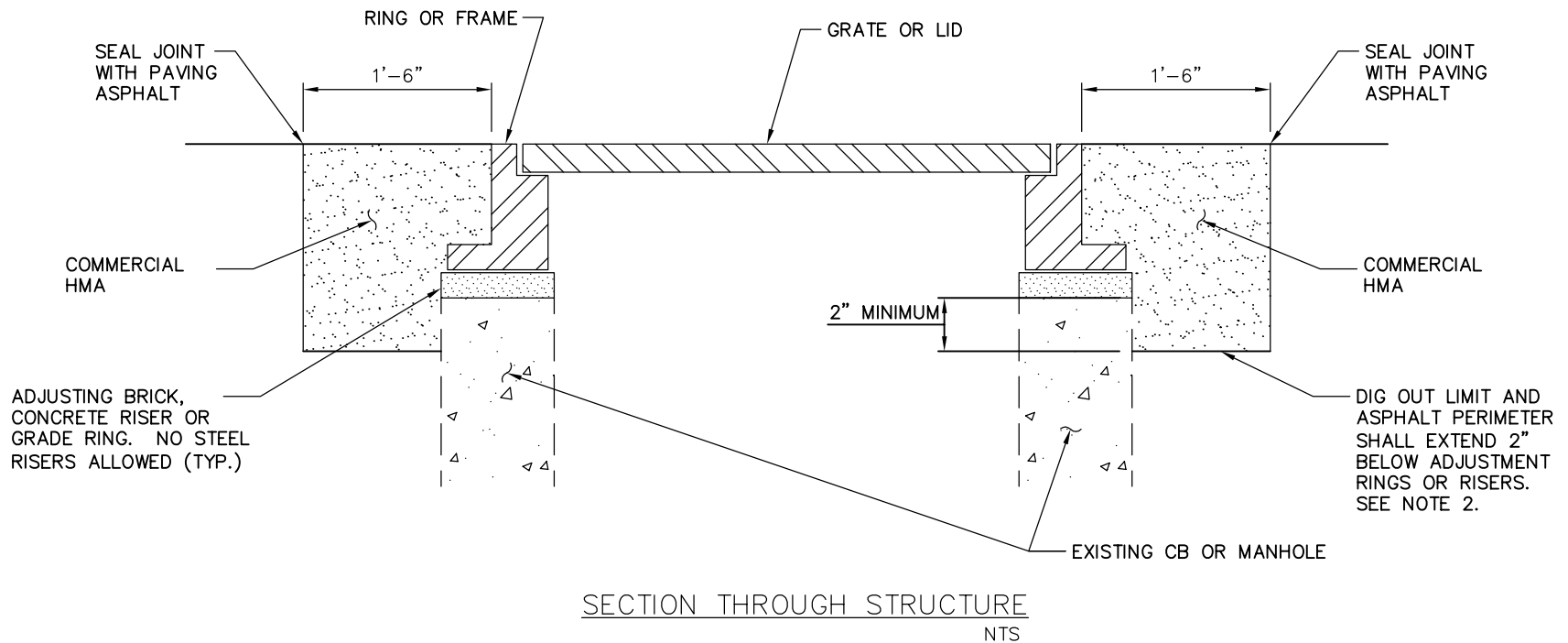

NOTES:

- 1) THE EXISTING STRUCTURE SHALL BE RAISED OR LOWERED TO THE REQUIRED ELEVATION USING CONCRETE BLOCKS, BRICK, AND/OR CONCRETE RINGS. EACH JOINT SHALL BE GROUTED USING A $\frac{3}{4}$ INCH LAYER OF NON-SHRINK MORTAR, PLASTERED SMOOTH INSIDE AND OUT. COVERS SHALL BE SEATED ON A UNIFORM LAYER OF GROUT TO PREVENT ROCKING.
- 2) IF RISERS OR GRADE RINGS ARE LESS THAN 2" THICK, THEN THE DIG-OUT LIMITS (AND HMA DEPTH) SHALL BE EXTENDED TO 2" BELOW THE NEXT RING OR RISER THAT IS GREATER THAN 2" THICK.
- 3) HMA SHALL BE MECHANICALLY COMPACTED IN 3" MAXIMUM LIFTS.
- 4) SEE DETAIL 3-36 FOR ADJUSTMENT OF SURVEY MONUMENT CASTINGS.

REV: NOV 2011

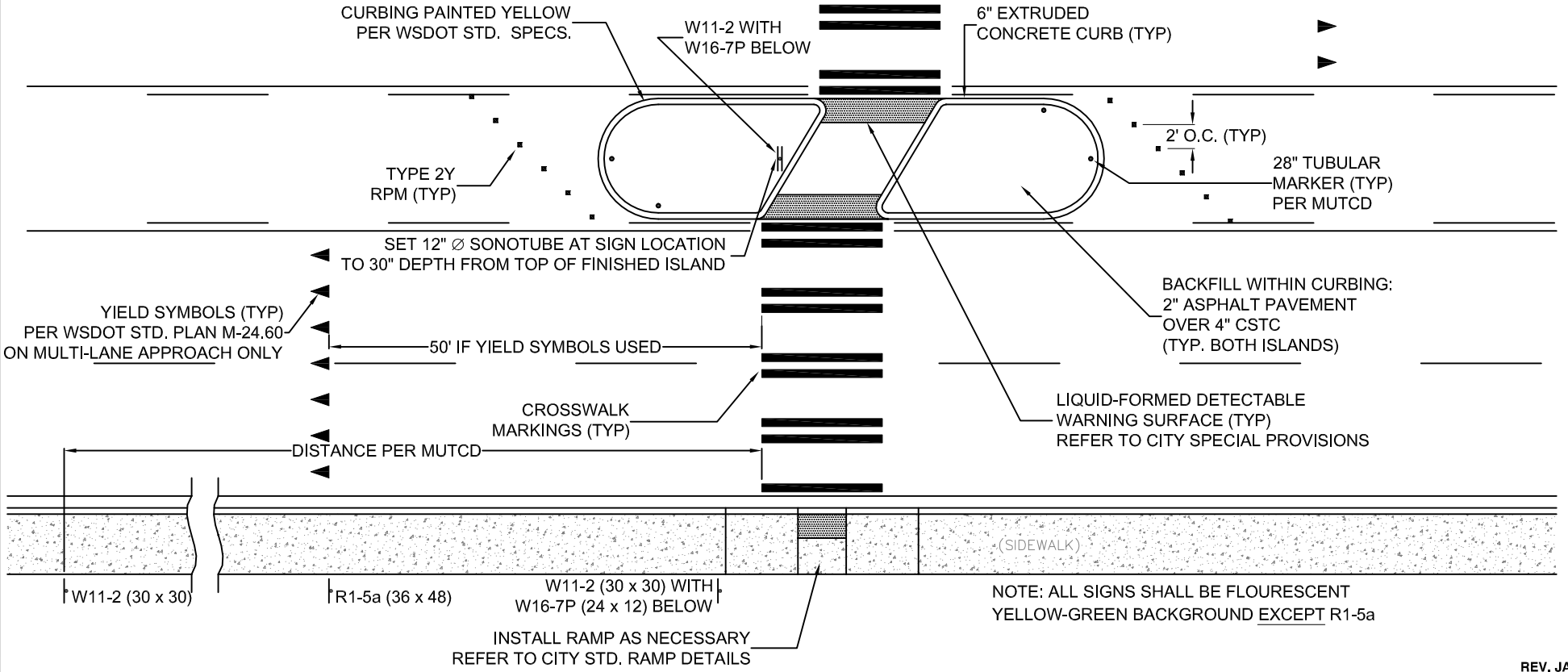
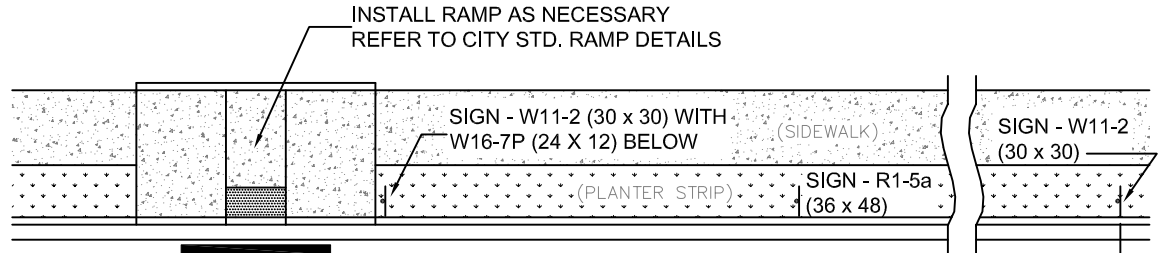
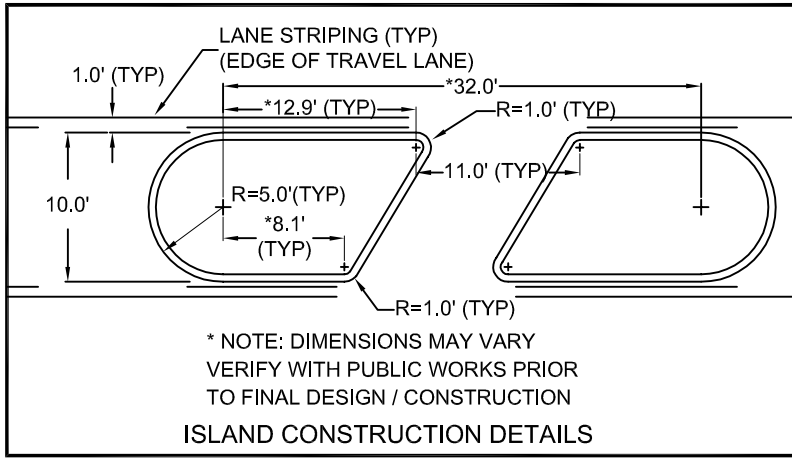

REV. JAN 2017

PREVAILING WAGES AND BENEFIT CODE KEY

CITY OF FEDERAL WAY

S. 320th STREET/21ST AVENUE S.
SIGNAL UPGRADES
PROJECT #36225

State of Washington
 Department of Labor & Industries
 Prevailing Wage Section - Telephone 360-902-5335
 PO Box 44540, Olympia, WA 98504-4540

Washington State Prevailing Wage

The PREVAILING WAGES listed here include both the hourly wage rate and the hourly rate of fringe benefits. On public works projects, worker's wage and benefit rates must add to not less than this total. A brief description of overtime calculation requirements are provided on the Benefit Code Key.

Journey Level Prevailing Wage Rates for the Effective Date: 12/18/2023

<u>County</u>	<u>Trade</u>	<u>Job Classification</u>	<u>Wage</u>	<u>Holiday</u>	<u>Overtime</u>	<u>Note</u>	<u>*Risk Class</u>
King	<u>Asbestos Abatement Workers</u>	Journey Level	\$59.07	<u>5D</u>	<u>1H</u>		<u>View</u>
King	<u>Boilermakers</u>	Journey Level	\$74.29	<u>5N</u>	<u>1C</u>		<u>View</u>
King	<u>Brick Mason</u>	Journey Level	\$69.07	<u>7E</u>	<u>1N</u>		<u>View</u>
King	<u>Brick Mason</u>	Pointer-Caulker-Cleaner	\$69.07	<u>7E</u>	<u>1N</u>		<u>View</u>
King	<u>Building Service Employees</u>	Janitor	\$29.33	<u>5S</u>	<u>2F</u>		<u>View</u>
King	<u>Building Service Employees</u>	Traveling Waxer/Shampooer	\$29.78	<u>5S</u>	<u>2F</u>		<u>View</u>
King	<u>Building Service Employees</u>	Window Cleaner (Non-Scaffold)	\$32.93	<u>5S</u>	<u>2F</u>		<u>View</u>
King	<u>Building Service Employees</u>	Window Cleaner (Scaffold)	\$33.93	<u>5S</u>	<u>2F</u>		<u>View</u>
King	<u>Cabinet Makers (In Shop)</u>	Journey Level	\$22.74		<u>1</u>		<u>View</u>
King	<u>Carpenters</u>	Acoustical Worker	\$74.96	<u>15J</u>	<u>4C</u>		<u>View</u>
King	<u>Carpenters</u>	Bridge, Dock And Wharf Carpenters	\$74.96	<u>15J</u>	<u>4C</u>		<u>View</u>
King	<u>Carpenters</u>	Floor Layer & Floor Finisher	\$74.96	<u>15J</u>	<u>4C</u>		<u>View</u>
King	<u>Carpenters</u>	Journey Level	\$74.96	<u>15J</u>	<u>4C</u>		<u>View</u>
King	<u>Carpenters</u>	Scaffold Erector	\$74.96	<u>15J</u>	<u>4C</u>		<u>View</u>
King	<u>Cement Masons</u>	Application of all Composition Mastic	\$72.87	<u>15J</u>	<u>4U</u>		<u>View</u>
King	<u>Cement Masons</u>	Application of all Epoxy Material	\$72.37	<u>15J</u>	<u>4U</u>		<u>View</u>
King	<u>Cement Masons</u>	Application of all Plastic Material	\$72.87	<u>15J</u>	<u>4U</u>		<u>View</u>
King	<u>Cement Masons</u>	Application of Sealing Compound	\$72.37	<u>15J</u>	<u>4U</u>		<u>View</u>
King	<u>Cement Masons</u>	Application of Underlayment	\$72.87	<u>15J</u>	<u>4U</u>		<u>View</u>
King	<u>Cement Masons</u>	Building General	\$72.37	<u>15J</u>	<u>4U</u>		<u>View</u>
King	<u>Cement Masons</u>	Composition or Kalman Floors	\$72.87	<u>15J</u>	<u>4U</u>		<u>View</u>
King	<u>Cement Masons</u>	Concrete Paving	\$72.37	<u>15J</u>	<u>4U</u>		<u>View</u>
King	<u>Cement Masons</u>	Curb & Gutter Machine	\$72.87	<u>15J</u>	<u>4U</u>		<u>View</u>
King	<u>Cement Masons</u>	Curb & Gutter, Sidewalks	\$72.37	<u>15J</u>	<u>4U</u>		<u>View</u>
King	<u>Cement Masons</u>	Curing Concrete	\$72.37	<u>15J</u>	<u>4U</u>		<u>View</u>
King	<u>Cement Masons</u>	Finish Colored Concrete	\$72.87	<u>15J</u>	<u>4U</u>		<u>View</u>

King	Cement Masons	Floor Grinding	\$72.87	15J	4U		View
King	Cement Masons	Floor Grinding/Polisher	\$72.37	15J	4U		View
King	Cement Masons	Green Concrete Saw, self-powered	\$72.87	15J	4U		View
King	Cement Masons	Grouting of all Plates	\$72.37	15J	4U		View
King	Cement Masons	Grouting of all Tilt-up Panels	\$72.37	15J	4U		View
King	Cement Masons	Guniting Nozzleman	\$72.87	15J	4U		View
King	Cement Masons	Hand Powered Grinder	\$72.87	15J	4U		View
King	Cement Masons	Journey Level	\$72.37	15J	4U		View
King	Cement Masons	Patching Concrete	\$72.37	15J	4U		View
King	Cement Masons	Pneumatic Power Tools	\$72.87	15J	4U		View
King	Cement Masons	Power Chipping & Brushing	\$72.87	15J	4U		View
King	Cement Masons	Sand Blasting Architectural Finish	\$72.87	15J	4U		View
King	Cement Masons	Screed & Rodding Machine	\$72.87	15J	4U		View
King	Cement Masons	Spackling or Skim Coat Concrete	\$72.37	15J	4U		View
King	Cement Masons	Troweling Machine Operator	\$72.87	15J	4U		View
King	Cement Masons	Troweling Machine Operator on Colored Slabs	\$72.87	15J	4U		View
King	Cement Masons	Tunnel Workers	\$72.87	15J	4U		View
King	Divers & Tenders	Bell/Vehicle or Submersible Operator (Not Under Pressure)	\$129.71	15J	4C		View
King	Divers & Tenders	Dive Supervisor/Master	\$93.94	15J	4C		View
King	Divers & Tenders	Diver	\$129.71	15J	4C	8V	View
King	Divers & Tenders	Diver On Standby	\$88.94	15J	4C		View
King	Divers & Tenders	Diver Tender	\$80.82	15J	4C		View
King	Divers & Tenders	Hyperbaric Worker - Compressed Air Worker 0-30.00 PSI	\$93.26	15J	4C		View
King	Divers & Tenders	Hyperbaric Worker - Compressed Air Worker 30.01 - 44.00 PSI	\$98.26	15J	4C		View
King	Divers & Tenders	Hyperbaric Worker - Compressed Air Worker 44.01 - 54.00 PSI	\$102.26	15J	4C		View
King	Divers & Tenders	Hyperbaric Worker - Compressed Air Worker 54.01 - 60.00 PSI	\$107.26	15J	4C		View
King	Divers & Tenders	Hyperbaric Worker - Compressed Air Worker 60.01 - 64.00 PSI	\$109.76	15J	4C		View
King	Divers & Tenders	Hyperbaric Worker - Compressed Air Worker 64.01 - 68.00 PSI	\$114.76	15J	4C		View
King	Divers & Tenders	Hyperbaric Worker - Compressed Air Worker 68.01 - 70.00 PSI	\$116.76	15J	4C		View
King	Divers & Tenders	Hyperbaric Worker - Compressed Air Worker 70.01 - 72.00 PSI	\$118.76	15J	4C		View

King	Divers & Tenders	Hyperbaric Worker - Compressed Air Worker 72.01 - 74.00 PSI	\$120.76	15J	4C		View
King	Divers & Tenders	Manifold Operator	\$80.82	15J	4C		View
King	Divers & Tenders	Manifold Operator Mixed Gas	\$85.82	15J	4C		View
King	Divers & Tenders	Remote Operated Vehicle Operator/Technician	\$80.82	15J	4C		View
King	Divers & Tenders	Remote Operated Vehicle Tender	\$75.41	15J	4C		View
King	Dredge Workers	Assistant Engineer	\$79.62	5D	3F		View
King	Dredge Workers	Assistant Mate (Deckhand)	\$79.01	5D	3F		View
King	Dredge Workers	Boatmen	\$79.62	5D	3F		View
King	Dredge Workers	Engineer Welder	\$81.15	5D	3F		View
King	Dredge Workers	Leverman, Hydraulic	\$82.77	5D	3F		View
King	Dredge Workers	Mates	\$79.62	5D	3F		View
King	Dredge Workers	Oiler	\$79.01	5D	3F		View
King	Drywall Applicator	Journey Level	\$74.96	15J	4C		View
King	Drywall Tapers	Journey Level	\$74.50	5P	1E		View
King	Electrical Fixture Maintenance Workers	Journey Level	\$37.19	5L	1E		View
King	Electricians - Inside	Cable Splicer	\$105.59	7C	4E		View
King	Electricians - Inside	Cable Splicer (tunnel)	\$113.52	7C	4E		View
King	Electricians - Inside	Certified Welder	\$101.98	7C	4E		View
King	Electricians - Inside	Certified Welder (tunnel)	\$109.56	7C	4E		View
King	Electricians - Inside	Construction Stock Person	\$49.28	7C	4E		View
King	Electricians - Inside	Journey Level	\$98.38	7C	4E		View
King	Electricians - Inside	Journey Level (tunnel)	\$105.59	7C	4E		View
King	Electricians - Motor Shop	Journey Level	\$48.68	5A	1B		View
King	Electricians - Powerline Construction	Cable Splicer	\$93.00	5A	4D		View
King	Electricians - Powerline Construction	Certified Line Welder	\$85.42	5A	4D		View
King	Electricians - Powerline Construction	Groundperson	\$55.27	5A	4D		View
King	Electricians - Powerline Construction	Heavy Line Equipment Operator	\$85.42	5A	4D		View
King	Electricians - Powerline Construction	Journey Level Lineperson	\$85.42	5A	4D		View
King	Electricians - Powerline Construction	Line Equipment Operator	\$73.35	5A	4D		View
King	Electricians - Powerline Construction	Meter Installer	\$55.27	5A	4D	8W	View
King	Electricians - Powerline Construction	Pole Sprayer	\$85.42	5A	4D		View
King	Electricians - Powerline Construction	Powderperson	\$63.50	5A	4D		View
King	Electronic Technicians	Journey Level	\$63.38	7E	1E		View
King	Elevator Constructors	Mechanic	\$107.49	7D	4A		View
King	Elevator Constructors	Mechanic In Charge	\$116.13	7D	4A		View

King	Fabricated Precast Concrete Products	All Classifications - In-Factory Work Only	\$21.34	5B	1R		View
King	Fence Erectors	Fence Erector	\$50.07	15J	11P	8Y	View
King	Fence Erectors	Fence Laborer	\$50.07	15J	11P	8Y	View
King	Flaggers	Journey Level	\$50.07	15J	11P	8Y	View
King	Glaziers	Journey Level	\$79.16	7L	1Y		View
King	Heat & Frost Insulators And Asbestos Workers	Journey Level	\$87.15	15H	11C		View
King	Heating Equipment Mechanics	Journey Level	\$96.42	7F	1E		View
King	Hod Carriers & Mason Tenders	Journey Level	\$62.49	15J	11P	8Y	View
King	Industrial Power Vacuum Cleaner	Journey Level	\$15.74		1		View
King	Inland Boatmen	Boat Operator	\$61.41	5B	1K		View
King	Inland Boatmen	Cook	\$56.48	5B	1K		View
King	Inland Boatmen	Deckhand	\$57.48	5B	1K		View
King	Inland Boatmen	Deckhand Engineer	\$58.81	5B	1K		View
King	Inland Boatmen	Launch Operator	\$58.89	5B	1K		View
King	Inland Boatmen	Mate	\$57.31	5B	1K		View
King	Inspection/Cleaning/Sealing Of Sewer & Water Systems By Remote Control	Cleaner Operator	\$49.48	15M	11O		View
King	Inspection/Cleaning/Sealing Of Sewer & Water Systems By Remote Control	Foamer Operator	\$49.48	15M	11O		View
King	Inspection/Cleaning/Sealing Of Sewer & Water Systems By Remote Control	Grout Truck Operator	\$49.48	15M	11O		View
King	Inspection/Cleaning/Sealing Of Sewer & Water Systems By Remote Control	Head Operator	\$47.41	15M	11O		View
King	Inspection/Cleaning/Sealing Of Sewer & Water Systems By Remote Control	Technician	\$41.20	15M	11O		View
King	Inspection/Cleaning/Sealing Of Sewer & Water Systems By Remote Control	TV Truck Operator	\$44.31	15M	11O		View
King	Insulation Applicators	Journey Level	\$74.96	15J	4C		View
King	Ironworkers	Journeyman	\$85.80	15K	11N		View
King	Laborers	Air, Gas Or Electric Vibrating Screed	\$59.07	15J	11P	8Y	View
King	Laborers	Airtrac Drill Operator	\$60.90	15J	11P	8Y	View
King	Laborers	Ballast Regular Machine	\$59.07	15J	11P	8Y	View
King	Laborers	Batch Weighman	\$50.07	15J	11P	8Y	View
King	Laborers	Brick Pavers	\$59.07	15J	11P	8Y	View
King	Laborers	Brush Cutter	\$59.07	15J	11P	8Y	View
King	Laborers	Brush Hog Feeder	\$59.07	15J	11P	8Y	View
King	Laborers	Burner	\$59.07	15J	11P	8Y	View
King	Laborers	Caisson Worker	\$60.90	15J	11P	8Y	View
King	Laborers	Carpenter Tender	\$59.07	15J	11P	8Y	View
King	Laborers	Cement Dumper-paving	\$60.15	15J	11P	8Y	View

King	Laborers	Cement Finisher Tender	\$59.07	15J	11P	8Y	View
King	Laborers	Change House Or Dry Shack	\$59.07	15J	11P	8Y	View
King	Laborers	Chipping Gun (30 Lbs. And Over)	\$60.15	15J	11P	8Y	View
King	Laborers	Chipping Gun (Under 30 Lbs.)	\$59.07	15J	11P	8Y	View
King	Laborers	Choker Setter	\$59.07	15J	11P	8Y	View
King	Laborers	Chuck Tender	\$59.07	15J	11P	8Y	View
King	Laborers	Clary Power Spreader	\$60.15	15J	11P	8Y	View
King	Laborers	Clean-up Laborer	\$59.07	15J	11P	8Y	View
King	Laborers	Concrete Dumper/Chute Operator	\$60.15	15J	11P	8Y	View
King	Laborers	Concrete Form Stripper	\$59.07	15J	11P	8Y	View
King	Laborers	Concrete Placement Crew	\$60.15	15J	11P	8Y	View
King	Laborers	Concrete Saw Operator/Core Driller	\$60.15	15J	11P	8Y	View
King	Laborers	Crusher Feeder	\$50.07	15J	11P	8Y	View
King	Laborers	Curing Laborer	\$59.07	15J	11P	8Y	View
King	Laborers	Demolition: Wrecking & Moving (Incl. Charred Material)	\$59.07	15J	11P	8Y	View
King	Laborers	Ditch Digger	\$59.07	15J	11P	8Y	View
King	Laborers	Diver	\$60.90	15J	11P	8Y	View
King	Laborers	Drill Operator (Hydraulic, Diamond)	\$60.15	15J	11P	8Y	View
King	Laborers	Dry Stack Walls	\$59.07	15J	11P	8Y	View
King	Laborers	Dump Person	\$59.07	15J	11P	8Y	View
King	Laborers	Epoxy Technician	\$59.07	15J	11P	8Y	View
King	Laborers	Erosion Control Worker	\$59.07	15J	11P	8Y	View
King	Laborers	Faller & Bucker Chain Saw	\$60.15	15J	11P	8Y	View
King	Laborers	Fine Graders	\$59.07	15J	11P	8Y	View
King	Laborers	Firewatch	\$50.07	15J	11P	8Y	View
King	Laborers	Form Setter	\$60.15	15J	11P	8Y	View
King	Laborers	Gabian Basket Builders	\$59.07	15J	11P	8Y	View
King	Laborers	General Laborer	\$59.07	15J	11P	8Y	View
King	Laborers	Grade Checker & Transit Person	\$62.49	15J	11P	8Y	View
King	Laborers	Grinders	\$59.07	15J	11P	8Y	View
King	Laborers	Grout Machine Tender	\$59.07	15J	11P	8Y	View
King	Laborers	Groutmen (Pressure) Including Post Tension Beams	\$60.15	15J	11P	8Y	View
King	Laborers	Guardrail Erector	\$59.07	15J	11P	8Y	View
King	Laborers	Hazardous Waste Worker (Level A)	\$60.90	15J	11P	8Y	View
King	Laborers	Hazardous Waste Worker (Level B)	\$60.15	15J	11P	8Y	View
King	Laborers	Hazardous Waste Worker (Level C)	\$59.07	15J	11P	8Y	View
King	Laborers	High Scaler	\$60.90	15J	11P	8Y	View
King	Laborers	Jackhammer	\$60.15	15J	11P	8Y	View
King	Laborers	Laserbeam Operator	\$60.15	15J	11P	8Y	View

King	Laborers	Maintenance Person	\$59.07	15J	11P	8Y	View
King	Laborers	Manhole Builder-Mudman	\$60.15	15J	11P	8Y	View
King	Laborers	Material Yard Person	\$59.07	15J	11P	8Y	View
King	Laborers	Mold Abatement Worker	\$59.07	15J	11P	8Y	View
King	Laborers	Motorman-Dinky Locomotive	\$62.59	15J	11P	8Y	View
King	Laborers	nozzleman (concrete pump, green cutter when using combination of high pressure air & water on concrete & rock, sandblast, gunite, shotcrete, water blaster, vacuum blaster)	\$62.49	15J	11P	8Y	View
King	Laborers	Pavement Breaker	\$60.15	15J	11P	8Y	View
King	Laborers	Pilot Car	\$50.07	15J	11P	8Y	View
King	Laborers	Pipe Layer (Lead)	\$62.49	15J	11P	8Y	View
King	Laborers	Pipe Layer/Tailor	\$60.15	15J	11P	8Y	View
King	Laborers	Pipe Pot Tender	\$60.15	15J	11P	8Y	View
King	Laborers	Pipe Reliner	\$60.15	15J	11P	8Y	View
King	Laborers	Pipe Wrapper	\$60.15	15J	11P	8Y	View
King	Laborers	Pot Tender	\$59.07	15J	11P	8Y	View
King	Laborers	Powderman	\$60.90	15J	11P	8Y	View
King	Laborers	Powderman's Helper	\$59.07	15J	11P	8Y	View
King	Laborers	Power Jacks	\$60.15	15J	11P	8Y	View
King	Laborers	Railroad Spike Puller - Power	\$60.15	15J	11P	8Y	View
King	Laborers	Raker - Asphalt	\$62.49	15J	11P	8Y	View
King	Laborers	Re-timberman	\$60.90	15J	11P	8Y	View
King	Laborers	Remote Equipment Operator	\$60.15	15J	11P	8Y	View
King	Laborers	Rigger/Signal Person	\$60.15	15J	11P	8Y	View
King	Laborers	Rip Rap Person	\$59.07	15J	11P	8Y	View
King	Laborers	Rivet Buster	\$60.15	15J	11P	8Y	View
King	Laborers	Rodder	\$60.15	15J	11P	8Y	View
King	Laborers	Scaffold Erector	\$59.07	15J	11P	8Y	View
King	Laborers	Scale Person	\$59.07	15J	11P	8Y	View
King	Laborers	Sloper (Over 20")	\$60.15	15J	11P	8Y	View
King	Laborers	Sloper Sprayer	\$59.07	15J	11P	8Y	View
King	Laborers	Spreader (Concrete)	\$60.15	15J	11P	8Y	View
King	Laborers	Stake Hopper	\$59.07	15J	11P	8Y	View
King	Laborers	Stock Piler	\$59.07	15J	11P	8Y	View
King	Laborers	Swinging Stage/Boatswain Chair	\$50.07	15J	11P	8Y	View
King	Laborers	Tamper & Similar Electric, Air & Gas Operated Tools	\$60.15	15J	11P	8Y	View
King	Laborers	Tamper (Multiple & Self-propelled)	\$60.15	15J	11P	8Y	View
King	Laborers	Timber Person - Sewer (Lagger, Shorer & Cribber)	\$60.15	15J	11P	8Y	View
King	Laborers	Toolroom Person (at Jobsite)	\$59.07	15J	11P	8Y	View
King	Laborers	Topper	\$59.07	15J	11P	8Y	View
King	Laborers	Track Laborer	\$59.07	15J	11P	8Y	View

King	Laborers	Track Liner (Power)	\$60.15	15J	11P	8Y	View
King	Laborers	Traffic Control Laborer	\$53.54	15J	11P	9C	View
King	Laborers	Traffic Control Supervisor	\$56.73	15J	11P	9C	View
King	Laborers	Truck Spotter	\$59.07	15J	11P	8Y	View
King	Laborers	Tugger Operator	\$60.15	15J	11P	8Y	View
King	Laborers	Tunnel Work-Compressed Air Worker 0-30 psi	\$175.79	15J	11P	9B	View
King	Laborers	Tunnel Work-Compressed Air Worker 30.01-44.00 psi	\$180.82	15J	11P	9B	View
King	Laborers	Tunnel Work-Compressed Air Worker 44.01-54.00 psi	\$184.50	15J	11P	9B	View
King	Laborers	Tunnel Work-Compressed Air Worker 54.01-60.00 psi	\$190.20	15J	11P	9B	View
King	Laborers	Tunnel Work-Compressed Air Worker 60.01-64.00 psi	\$192.32	15J	11P	9B	View
King	Laborers	Tunnel Work-Compressed Air Worker 64.01-68.00 psi	\$197.42	15J	11P	9B	View
King	Laborers	Tunnel Work-Compressed Air Worker 68.01-70.00 psi	\$199.32	15J	11P	9B	View
King	Laborers	Tunnel Work-Compressed Air Worker 70.01-72.00 psi	\$201.32	15J	11P	9B	View
King	Laborers	Tunnel Work-Compressed Air Worker 72.01-74.00 psi	\$203.32	15J	11P	9B	View
King	Laborers	Tunnel Work-Guage and Lock Tender	\$62.59	15J	11P	8Y	View
King	Laborers	Tunnel Work-Miner	\$62.59	15J	11P	8Y	View
King	Laborers	Vibrator	\$60.15	15J	11P	8Y	View
King	Laborers	Vinyl Seamer	\$59.07	15J	11P	8Y	View
King	Laborers	Watchman	\$45.51	15J	11P	8Y	View
King	Laborers	Welder	\$60.15	15J	11P	8Y	View
King	Laborers	Well Point Laborer	\$60.15	15J	11P	8Y	View
King	Laborers	Window Washer/Cleaner	\$45.51	15J	11P	8Y	View
King	Laborers - Underground Sewer & Water	General Laborer & Topman	\$59.07	15J	11P	8Y	View
King	Laborers - Underground Sewer & Water	Pipe Layer	\$60.15	15J	11P	8Y	View
King	Landscape Construction	Landscape Construction/Landscaping Or Planting Laborers	\$45.51	15J	11P	8Y	View
King	Landscape Construction	Landscape Operator	\$82.25	15J	11G	8X	View
King	Landscape Maintenance	Groundskeeper	\$17.87		1		View
King	Lathers	Journey Level	\$74.96	15J	4C		View
King	Marble Setters	Journey Level	\$69.07	7E	1N		View
King	Metal Fabrication (In Shop)	Fitter/Certified Welder	\$42.17	15I	11E		View
King	Metal Fabrication (In Shop)	General Laborer	\$30.07	15I	11E		View
King	Metal Fabrication (In Shop)	Mechanic	\$43.63	15I	11E		View
King	Metal Fabrication (In Shop)	Welder/Burner	\$39.28	15I	11E		View
King	Millwright	Journey Level	\$76.51	15J	4C		View
King	Modular Buildings	Cabinet Assembly	\$15.74		1		View
King	Modular Buildings	Electrician	\$15.74		1		View

King	Modular Buildings	Equipment Maintenance	\$15.74		<u>1</u>		View
King	Modular Buildings	Plumber	\$15.74		<u>1</u>		View
King	Modular Buildings	Production Worker	\$15.74		<u>1</u>		View
King	Modular Buildings	Tool Maintenance	\$15.74		<u>1</u>		View
King	Modular Buildings	Utility Person	\$15.74		<u>1</u>		View
King	Modular Buildings	Welder	\$15.74		<u>1</u>		View
King	Painters	Journey Level	\$51.71	<u>6Z</u>	<u>11J</u>		View
King	Pile Driver	Crew Tender	\$80.82	<u>15J</u>	<u>4C</u>		View
King	Pile Driver	Journey Level	\$75.41	<u>15J</u>	<u>4C</u>		View
King	Plasterers	Journey Level	\$70.91	<u>7Q</u>	<u>1R</u>		View
King	Plasterers	Nozzleman	\$74.91	<u>7Q</u>	<u>1R</u>		View
King	Playground & Park Equipment Installers	Journey Level	\$15.74		<u>1</u>		View
King	Plumbers & Pipefitters	Journey Level	\$100.69	<u>6Z</u>	<u>1G</u>		View
King	Power Equipment Operators	Asphalt Plant Operators	\$83.62	<u>15J</u>	<u>11G</u>	<u>8X</u>	View
King	Power Equipment Operators	Assistant Engineer	\$78.65	<u>15J</u>	<u>11G</u>	<u>8X</u>	View
King	Power Equipment Operators	Barrier Machine (zipper)	\$82.88	<u>15J</u>	<u>11G</u>	<u>8X</u>	View
King	Power Equipment Operators	Batch Plant Operator: concrete	\$82.88	<u>15J</u>	<u>11G</u>	<u>8X</u>	View
King	Power Equipment Operators	Boat Operator	\$83.95	<u>7A</u>	<u>11H</u>	<u>8X</u>	View
King	Power Equipment Operators	Bobcat	\$78.65	<u>15J</u>	<u>11G</u>	<u>8X</u>	View
King	Power Equipment Operators	Brokk - Remote Demolition Equipment	\$78.65	<u>15J</u>	<u>11G</u>	<u>8X</u>	View
King	Power Equipment Operators	Brooms	\$78.65	<u>15J</u>	<u>11G</u>	<u>8X</u>	View
King	Power Equipment Operators	Bump Cutter	\$82.88	<u>15J</u>	<u>11G</u>	<u>8X</u>	View
King	Power Equipment Operators	Cableways	\$83.62	<u>15J</u>	<u>11G</u>	<u>8X</u>	View
King	Power Equipment Operators	Chipper	\$82.88	<u>15J</u>	<u>11G</u>	<u>8X</u>	View
King	Power Equipment Operators	Compressor	\$78.65	<u>15J</u>	<u>11G</u>	<u>8X</u>	View
King	Power Equipment Operators	Concrete Finish Machine - Laser Screed	\$78.65	<u>15J</u>	<u>11G</u>	<u>8X</u>	View
King	Power Equipment Operators	Concrete Pump - Mounted Or Trailer High Pressure Line Pump, Pump High Pressure	\$82.25	<u>15J</u>	<u>11G</u>	<u>8X</u>	View
King	Power Equipment Operators	Concrete Pump: Truck Mount With Boom Attachment Over 42 M	\$83.62	<u>15J</u>	<u>11G</u>	<u>8X</u>	View
King	Power Equipment Operators	Concrete Pump: Truck Mount With Boom Attachment Up To 42m	\$82.88	<u>15J</u>	<u>11G</u>	<u>8X</u>	View
King	Power Equipment Operators	Conveyors	\$82.25	<u>15J</u>	<u>11G</u>	<u>8X</u>	View
King	Power Equipment Operators	Cranes Friction: 200 tons and over	\$86.48	<u>7A</u>	<u>11H</u>	<u>8X</u>	View
King	Power Equipment Operators	Cranes, A-frame: 10 tons and under	\$78.95	<u>7A</u>	<u>11H</u>	<u>8X</u>	View
King	Power Equipment Operators	Cranes: 100 tons through 199 tons, or 150' of boom (including jib with attachments)	\$84.77	<u>7A</u>	<u>11H</u>	<u>8X</u>	View
King	Power Equipment Operators	Cranes: 20 tons through 44 tons with attachments	\$83.20	<u>7A</u>	<u>11H</u>	<u>8X</u>	View

King	<u>Power Equipment Operators</u>	Cranes: 200 tons- 299 tons, or 250' of boom including jib with attachments	\$85.66	<u>7A</u>	<u>11H</u>	<u>8X</u>	<u>View</u>
King	<u>Power Equipment Operators</u>	Cranes: 300 tons and over or 300' of boom including jib with attachments	\$86.48	<u>7A</u>	<u>11H</u>	<u>8X</u>	<u>View</u>
King	<u>Power Equipment Operators</u>	Cranes: 45 tons through 99 tons, under 150' of boom(including jib with attachments)	\$83.95	<u>7A</u>	<u>11H</u>	<u>8X</u>	<u>View</u>
King	<u>Power Equipment Operators</u>	Cranes: Friction cranes through 199 tons	\$85.66	<u>7A</u>	<u>11H</u>	<u>8X</u>	<u>View</u>
King	<u>Power Equipment Operators</u>	Cranes: through 19 tons with attachments, a-frame over 10 tons	\$82.56	<u>7A</u>	<u>11H</u>	<u>8X</u>	<u>View</u>
King	<u>Power Equipment Operators</u>	Crusher	\$82.88	<u>15J</u>	<u>11G</u>	<u>8X</u>	<u>View</u>
King	<u>Power Equipment Operators</u>	Deck Engineer/Deck Winches (power)	\$82.88	<u>15J</u>	<u>11G</u>	<u>8X</u>	<u>View</u>
King	<u>Power Equipment Operators</u>	Derricks, On Building Work	\$83.62	<u>15J</u>	<u>11G</u>	<u>8X</u>	<u>View</u>
King	<u>Power Equipment Operators</u>	Dozers D-9 & Under	\$82.25	<u>15J</u>	<u>11G</u>	<u>8X</u>	<u>View</u>
King	<u>Power Equipment Operators</u>	Drill Oilers: Auger Type, Truck Or Crane Mount	\$82.25	<u>15J</u>	<u>11G</u>	<u>8X</u>	<u>View</u>
King	<u>Power Equipment Operators</u>	Drilling Machine	\$84.46	<u>15J</u>	<u>11G</u>	<u>8X</u>	<u>View</u>
King	<u>Power Equipment Operators</u>	Elevator and man-lift: permanent and shaft type	\$78.65	<u>15J</u>	<u>11G</u>	<u>8X</u>	<u>View</u>
King	<u>Power Equipment Operators</u>	Finishing Machine, Bidwell And Gamaco & Similar Equipment	\$82.88	<u>15J</u>	<u>11G</u>	<u>8X</u>	<u>View</u>
King	<u>Power Equipment Operators</u>	Forklift: 3000 lbs and over with attachments	\$82.25	<u>15J</u>	<u>11G</u>	<u>8X</u>	<u>View</u>
King	<u>Power Equipment Operators</u>	Forklifts: under 3000 lbs. with attachments	\$78.65	<u>15J</u>	<u>11G</u>	<u>8X</u>	<u>View</u>
King	<u>Power Equipment Operators</u>	Grade Engineer: Using Blue Prints, Cut Sheets, Etc	\$82.88	<u>15J</u>	<u>11G</u>	<u>8X</u>	<u>View</u>
King	<u>Power Equipment Operators</u>	Gradechecker/Stakeman	\$78.65	<u>15J</u>	<u>11G</u>	<u>8X</u>	<u>View</u>
King	<u>Power Equipment Operators</u>	Guardrail Punch	\$82.88	<u>15J</u>	<u>11G</u>	<u>8X</u>	<u>View</u>
King	<u>Power Equipment Operators</u>	Hard Tail End Dump Articulating Off- Road Equipment 45 Yards. & Over	\$83.62	<u>15J</u>	<u>11G</u>	<u>8X</u>	<u>View</u>
King	<u>Power Equipment Operators</u>	Hard Tail End Dump Articulating Off-road Equipment Under 45 Yards	\$82.88	<u>15J</u>	<u>11G</u>	<u>8X</u>	<u>View</u>
King	<u>Power Equipment Operators</u>	Horizontal/Directional Drill Locator	\$82.25	<u>15J</u>	<u>11G</u>	<u>8X</u>	<u>View</u>
King	<u>Power Equipment Operators</u>	Horizontal/Directional Drill Operator	\$82.88	<u>15J</u>	<u>11G</u>	<u>8X</u>	<u>View</u>
King	<u>Power Equipment Operators</u>	Hydralifts/Boom Trucks Over 10 Tons	\$82.56	<u>7A</u>	<u>11H</u>	<u>8X</u>	<u>View</u>
King	<u>Power Equipment Operators</u>	Hydralifts/boom trucks: 10 tons and under	\$78.95	<u>7A</u>	<u>11H</u>	<u>8X</u>	<u>View</u>
King	<u>Power Equipment Operators</u>	Leverman	\$85.33	<u>15J</u>	<u>11G</u>	<u>8X</u>	<u>View</u>
King	<u>Power Equipment Operators</u>	Loader, Overhead, 6 Yards. But Not Including 8 Yards	\$83.62	<u>15J</u>	<u>11G</u>	<u>8X</u>	<u>View</u>

King	Power Equipment Operators	Loaders, Overhead Under 6 Yards	\$82.88	15J	11G	8X	View
King	Power Equipment Operators	Loaders, Plant Feed	\$82.88	15J	11G	8X	View
King	Power Equipment Operators	Loaders: Elevating Type Belt	\$82.25	15J	11G	8X	View
King	Power Equipment Operators	Locomotives, All	\$82.88	15J	11G	8X	View
King	Power Equipment Operators	Material Transfer Device	\$82.88	15J	11G	8X	View
King	Power Equipment Operators	Mechanics: All (Leadmen - \$0.50 per hour over mechanic)	\$84.46	15J	11G	8X	View
King	Power Equipment Operators	Motor Patrol Graders	\$83.62	15J	11G	8X	View
King	Power Equipment Operators	Mucking Machine, Mole, Tunnel Drill, Boring, Road Header And/or Shield	\$83.62	15J	11G	8X	View
King	Power Equipment Operators	Oil Distributors, Blower Distribution & Mulch Seeding Operator	\$78.65	15J	11G	8X	View
King	Power Equipment Operators	Outside Hoists (Elevators and Manlifts), Air Tuggers, Strato	\$82.25	15J	11G	8X	View
King	Power Equipment Operators	Overhead, bridge type Crane: 20 tons through 44 tons	\$83.20	7A	11H	8X	View
King	Power Equipment Operators	Overhead, bridge type: 100 tons and over	\$84.77	7A	11H	8X	View
King	Power Equipment Operators	Overhead, bridge type: 45 tons through 99 tons	\$83.95	7A	11H	8X	View
King	Power Equipment Operators	Pavement Breaker	\$78.65	15J	11G	8X	View
King	Power Equipment Operators	Pile Driver (other Than Crane Mount)	\$82.88	15J	11G	8X	View
King	Power Equipment Operators	Plant Oiler - Asphalt, Crusher	\$82.25	15J	11G	8X	View
King	Power Equipment Operators	Posthole Digger, Mechanical	\$78.65	15J	11G	8X	View
King	Power Equipment Operators	Power Plant	\$78.65	15J	11G	8X	View
King	Power Equipment Operators	Pumps - Water	\$78.65	15J	11G	8X	View
King	Power Equipment Operators	Quad 9, Hd 41, D10 And Over	\$83.62	15J	11G	8X	View
King	Power Equipment Operators	Quick Tower: no cab, under 100 feet in height base to boom	\$82.88	15J	11G	8X	View
King	Power Equipment Operators	Remote Control Operator On Rubber Tired Earth Moving Equipment	\$83.62	15J	11G	8X	View
King	Power Equipment Operators	Rigger and Bellman	\$78.95	7A	11H	8X	View
King	Power Equipment Operators	Rigger/Signal Person, Bellman(Certified)	\$82.56	7A	11H	8X	View
King	Power Equipment Operators	Rollagon	\$83.62	15J	11G	8X	View
King	Power Equipment Operators	Roller, Other Than Plant Mix	\$78.65	15J	11G	8X	View
King	Power Equipment Operators	Roller, Plant Mix Or Multi-lift Materials	\$82.25	15J	11G	8X	View
King	Power Equipment Operators	Roto-mill, Roto-grinder	\$82.88	15J	11G	8X	View
King	Power Equipment Operators	Saws - Concrete	\$82.25	15J	11G	8X	View
King	Power Equipment Operators	Scraper, Self Propelled Under 45 Yards	\$82.88	15J	11G	8X	View
King	Power Equipment Operators	Scrapers - Concrete & Carry All	\$82.25	15J	11G	8X	View
King	Power Equipment Operators	Scrapers, Self-propelled: 45 Yards And Over	\$83.62	15J	11G	8X	View

King	Power Equipment Operators	Service Engineers: Equipment	\$82.25	15J	11G	8X	View
King	Power Equipment Operators	Shotcrete/Gunite Equipment	\$78.65	15J	11G	8X	View
King	Power Equipment Operators	Shovel, Excavator, Backhoe, Tractors Under 15 Metric Tons	\$82.25	15J	11G	8X	View
King	Power Equipment Operators	Shovel, Excavator, Backhoe: Over 30 Metric Tons To 50 Metric Tons	\$83.62	15J	11G	8X	View
King	Power Equipment Operators	Shovel, Excavator, Backhoes, Tractors: 15 To 30 Metric Tons	\$82.88	15J	11G	8X	View
King	Power Equipment Operators	Shovel, Excavator, Backhoes: Over 50 Metric Tons To 90 Metric Tons	\$84.46	15J	11G	8X	View
King	Power Equipment Operators	Shovel, Excavator, Backhoes: Over 90 Metric Tons	\$85.33	15J	11G	8X	View
King	Power Equipment Operators	Slipform Pavers	\$83.62	15J	11G	8X	View
King	Power Equipment Operators	Spreader, Topsider & Screedman	\$83.62	15J	11G	8X	View
King	Power Equipment Operators	Subgrader Trimmer	\$82.88	15J	11G	8X	View
King	Power Equipment Operators	Tower Bucket Elevators	\$82.25	15J	11G	8X	View
King	Power Equipment Operators	Tower Crane: over 175' through 250' in height, base to boom	\$85.66	7A	11H	8X	View
King	Power Equipment Operators	Tower crane: up to 175' in height base to boom	\$84.77	7A	11H	8X	View
King	Power Equipment Operators	Tower Cranes: over 250' in height from base to boom	\$86.48	7A	11H	8X	View
King	Power Equipment Operators	Transporters, All Track Or Truck Type	\$83.62	15J	11G	8X	View
King	Power Equipment Operators	Trenching Machines	\$82.25	15J	11G	8X	View
King	Power Equipment Operators	Truck Crane Oiler/Driver: 100 tons and over	\$83.20	7A	11H	8X	View
King	Power Equipment Operators	Truck crane oiler/driver: under 100 tons	\$82.56	7A	11H	8X	View
King	Power Equipment Operators	Truck Mount Portable Conveyor	\$82.88	15J	11G	8X	View
King	Power Equipment Operators	Vac Truck (Vactor Guzzler, Hydro Excavator)	\$82.88	15J	11G	8X	View
King	Power Equipment Operators	Welder	\$83.62	15J	11G	8X	View
King	Power Equipment Operators	Wheel Tractors, Farmall Type	\$78.65	15J	11G	8X	View
King	Power Equipment Operators	Yo Yo Pay Dozer	\$82.88	15J	11G	8X	View
King	Power Equipment Operators-Underground Sewer & Water	Asphalt Plant Operators	\$83.62	15J	11G	8X	View
King	Power Equipment Operators-Underground Sewer & Water	Assistant Engineer	\$78.65	15J	11G	8X	View
King	Power Equipment Operators-Underground Sewer & Water	Barrier Machine (zipper)	\$82.88	15J	11G	8X	View
King	Power Equipment Operators-Underground Sewer & Water	Batch Plant Operator, Concrete	\$82.88	15J	11G	8X	View
King	Power Equipment Operators-Underground Sewer & Water	Boat Operator	\$83.95	7A	11H	8X	View
King	Power Equipment Operators-Underground Sewer & Water	Bobcat	\$78.65	15J	11G	8X	View
King	Power Equipment Operators-	Brokk - Remote Demolition	\$78.65	15J	11G	8X	View

	<u>Underground Sewer & Water</u>	Equipment					
King	<u>Power Equipment Operators- Underground Sewer & Water</u>	Brooms	\$78.65	<u>15J</u>	<u>11G</u>	<u>8X</u>	<u>View</u>
King	<u>Power Equipment Operators- Underground Sewer & Water</u>	Bump Cutter	\$82.88	<u>15J</u>	<u>11G</u>	<u>8X</u>	<u>View</u>
King	<u>Power Equipment Operators- Underground Sewer & Water</u>	Cableways	\$83.62	<u>15J</u>	<u>11G</u>	<u>8X</u>	<u>View</u>
King	<u>Power Equipment Operators- Underground Sewer & Water</u>	Chipper	\$82.88	<u>15J</u>	<u>11G</u>	<u>8X</u>	<u>View</u>
King	<u>Power Equipment Operators- Underground Sewer & Water</u>	Compressor	\$78.65	<u>15J</u>	<u>11G</u>	<u>8X</u>	<u>View</u>
King	<u>Power Equipment Operators- Underground Sewer & Water</u>	Concrete Finish Machine - Laser Screed	\$78.65	<u>15J</u>	<u>11G</u>	<u>8X</u>	<u>View</u>
King	<u>Power Equipment Operators- Underground Sewer & Water</u>	Concrete Pump - Mounted Or Trailer High Pressure Line Pump, Pump High Pressure	\$82.25	<u>15J</u>	<u>11G</u>	<u>8X</u>	<u>View</u>
King	<u>Power Equipment Operators- Underground Sewer & Water</u>	Concrete Pump: Truck Mount With Boom Attachment Over 42 M	\$83.62	<u>15J</u>	<u>11G</u>	<u>8X</u>	<u>View</u>
King	<u>Power Equipment Operators- Underground Sewer & Water</u>	Concrete Pump: Truck Mount With Boom Attachment Up To 42m	\$82.88	<u>15J</u>	<u>11G</u>	<u>8X</u>	<u>View</u>
King	<u>Power Equipment Operators- Underground Sewer & Water</u>	Conveyors	\$82.25	<u>15J</u>	<u>11G</u>	<u>8X</u>	<u>View</u>
King	<u>Power Equipment Operators- Underground Sewer & Water</u>	Cranes Friction: 200 tons and over	\$86.48	<u>7A</u>	<u>11H</u>	<u>8X</u>	<u>View</u>
King	<u>Power Equipment Operators- Underground Sewer & Water</u>	Cranes, A-frame: 10 tons and under	\$78.95	<u>7A</u>	<u>11H</u>	<u>8X</u>	<u>View</u>
King	<u>Power Equipment Operators- Underground Sewer & Water</u>	Cranes: 100 tons through 199 tons, or 150' of boom (including jib with attachments)	\$84.77	<u>7A</u>	<u>11H</u>	<u>8X</u>	<u>View</u>
King	<u>Power Equipment Operators- Underground Sewer & Water</u>	Cranes: 20 tons through 44 tons with attachments	\$83.20	<u>7A</u>	<u>11H</u>	<u>8X</u>	<u>View</u>
King	<u>Power Equipment Operators- Underground Sewer & Water</u>	Cranes: 200 tons- 299 tons, or 250' of boom including jib with attachments	\$85.66	<u>7A</u>	<u>11H</u>	<u>8X</u>	<u>View</u>
King	<u>Power Equipment Operators- Underground Sewer & Water</u>	Cranes: 300 tons and over or 300' of boom including jib with attachments	\$86.48	<u>7A</u>	<u>11H</u>	<u>8X</u>	<u>View</u>
King	<u>Power Equipment Operators- Underground Sewer & Water</u>	Cranes: 45 tons through 99 tons, under 150' of boom(including jib with attachments)	\$83.95	<u>7A</u>	<u>11H</u>	<u>8X</u>	<u>View</u>
King	<u>Power Equipment Operators- Underground Sewer & Water</u>	Cranes: Friction cranes through 199 tons	\$85.66	<u>7A</u>	<u>11H</u>	<u>8X</u>	<u>View</u>
King	<u>Power Equipment Operators- Underground Sewer & Water</u>	Cranes: through 19 tons with attachments, a-frame over 10 tons	\$82.56	<u>7A</u>	<u>11H</u>	<u>8X</u>	<u>View</u>
King	<u>Power Equipment Operators- Underground Sewer & Water</u>	Crusher	\$82.88	<u>15J</u>	<u>11G</u>	<u>8X</u>	<u>View</u>
King	<u>Power Equipment Operators- Underground Sewer & Water</u>	Deck Engineer/Deck Winches (power)	\$82.88	<u>15J</u>	<u>11G</u>	<u>8X</u>	<u>View</u>

King	<u>Power Equipment Operators-Underground Sewer & Water</u>	Derricks, On Building Work	\$83.62	<u>15J</u>	<u>11G</u>	<u>8X</u>	<u>View</u>
King	<u>Power Equipment Operators-Underground Sewer & Water</u>	Dozers D-9 & Under	\$82.25	<u>15J</u>	<u>11G</u>	<u>8X</u>	<u>View</u>
King	<u>Power Equipment Operators-Underground Sewer & Water</u>	Drill Oilers: Auger Type, Truck Or Crane Mount	\$82.25	<u>15J</u>	<u>11G</u>	<u>8X</u>	<u>View</u>
King	<u>Power Equipment Operators-Underground Sewer & Water</u>	Drilling Machine	\$84.46	<u>15J</u>	<u>11G</u>	<u>8X</u>	<u>View</u>
King	<u>Power Equipment Operators-Underground Sewer & Water</u>	Elevator and man-lift: permanent and shaft type	\$78.65	<u>15J</u>	<u>11G</u>	<u>8X</u>	<u>View</u>
King	<u>Power Equipment Operators-Underground Sewer & Water</u>	Finishing Machine, Bidwell And Gamaco & Similar Equipment	\$82.88	<u>15J</u>	<u>11G</u>	<u>8X</u>	<u>View</u>
King	<u>Power Equipment Operators-Underground Sewer & Water</u>	Forklift: 3000 lbs and over with attachments	\$82.25	<u>15J</u>	<u>11G</u>	<u>8X</u>	<u>View</u>
King	<u>Power Equipment Operators-Underground Sewer & Water</u>	Forklifts: under 3000 lbs. with attachments	\$78.65	<u>15J</u>	<u>11G</u>	<u>8X</u>	<u>View</u>
King	<u>Power Equipment Operators-Underground Sewer & Water</u>	Grade Engineer: Using Blue Prints, Cut Sheets, Etc	\$82.88	<u>15J</u>	<u>11G</u>	<u>8X</u>	<u>View</u>
King	<u>Power Equipment Operators-Underground Sewer & Water</u>	Gradechecker/Stakeman	\$78.65	<u>15J</u>	<u>11G</u>	<u>8X</u>	<u>View</u>
King	<u>Power Equipment Operators-Underground Sewer & Water</u>	Guardrail Punch	\$82.88	<u>15J</u>	<u>11G</u>	<u>8X</u>	<u>View</u>
King	<u>Power Equipment Operators-Underground Sewer & Water</u>	Hard Tail End Dump Articulating Off- Road Equipment 45 Yards. & Over	\$83.62	<u>15J</u>	<u>11G</u>	<u>8X</u>	<u>View</u>
King	<u>Power Equipment Operators-Underground Sewer & Water</u>	Hard Tail End Dump Articulating Off-road Equipment Under 45 Yards	\$82.88	<u>15J</u>	<u>11G</u>	<u>8X</u>	<u>View</u>
King	<u>Power Equipment Operators-Underground Sewer & Water</u>	Horizontal/Directional Drill Locator	\$82.25	<u>15J</u>	<u>11G</u>	<u>8X</u>	<u>View</u>
King	<u>Power Equipment Operators-Underground Sewer & Water</u>	Horizontal/Directional Drill Operator	\$82.88	<u>15J</u>	<u>11G</u>	<u>8X</u>	<u>View</u>
King	<u>Power Equipment Operators-Underground Sewer & Water</u>	Hydralifts/boom trucks: 10 tons and under	\$78.95	<u>7A</u>	<u>11H</u>	<u>8X</u>	<u>View</u>
King	<u>Power Equipment Operators-Underground Sewer & Water</u>	Hydralifts/boom trucks: over 10 tons	\$82.56	<u>7A</u>	<u>11H</u>	<u>8X</u>	<u>View</u>
King	<u>Power Equipment Operators-Underground Sewer & Water</u>	Leverman	\$85.33	<u>15J</u>	<u>11G</u>	<u>8X</u>	<u>View</u>
King	<u>Power Equipment Operators-Underground Sewer & Water</u>	Loader, Overhead, 6 Yards. But Not Including 8 Yards	\$83.62	<u>15J</u>	<u>11G</u>	<u>8X</u>	<u>View</u>
King	<u>Power Equipment Operators-Underground Sewer & Water</u>	Loaders, Overhead Under 6 Yards	\$82.88	<u>15J</u>	<u>11G</u>	<u>8X</u>	<u>View</u>
King	<u>Power Equipment Operators-Underground Sewer & Water</u>	Loaders, Plant Feed	\$82.88	<u>15J</u>	<u>11G</u>	<u>8X</u>	<u>View</u>
King	<u>Power Equipment Operators-Underground Sewer & Water</u>	Loaders: Elevating Type Belt	\$82.25	<u>15J</u>	<u>11G</u>	<u>8X</u>	<u>View</u>
King	<u>Power Equipment Operators-Underground Sewer & Water</u>	Locomotives, All	\$82.88	<u>15J</u>	<u>11G</u>	<u>8X</u>	<u>View</u>
King	<u>Power Equipment Operators-Underground Sewer & Water</u>	Material Transfer Device	\$82.88	<u>15J</u>	<u>11G</u>	<u>8X</u>	<u>View</u>
King	<u>Power Equipment Operators-Underground Sewer & Water</u>	Mechanics: All (Leadmen - \$0.50 per hour over mechanic)	\$84.46	<u>15J</u>	<u>11G</u>	<u>8X</u>	<u>View</u>

King	<u>Power Equipment Operators-Underground Sewer & Water</u>	Motor Patrol Graders	\$83.62	<u>15J</u>	<u>11G</u>	<u>8X</u>	<u>View</u>
King	<u>Power Equipment Operators-Underground Sewer & Water</u>	Mucking Machine, Mole, Tunnel Drill, Boring, Road Header And/or Shield	\$83.62	<u>15J</u>	<u>11G</u>	<u>8X</u>	<u>View</u>
King	<u>Power Equipment Operators-Underground Sewer & Water</u>	Oil Distributors, Blower Distribution & Mulch Seeding Operator	\$78.65	<u>15J</u>	<u>11G</u>	<u>8X</u>	<u>View</u>
King	<u>Power Equipment Operators-Underground Sewer & Water</u>	Outside Hoists (Elevators and Manlifts), Air Tuggers, Strato	\$82.25	<u>15J</u>	<u>11G</u>	<u>8X</u>	<u>View</u>
King	<u>Power Equipment Operators-Underground Sewer & Water</u>	Overhead, bridge type Crane: 20 tons through 44 tons	\$83.20	<u>7A</u>	<u>11H</u>	<u>8X</u>	<u>View</u>
King	<u>Power Equipment Operators-Underground Sewer & Water</u>	Overhead, bridge type: 100 tons and over	\$84.77	<u>7A</u>	<u>11H</u>	<u>8X</u>	<u>View</u>
King	<u>Power Equipment Operators-Underground Sewer & Water</u>	Overhead, bridge type: 45 tons through 99 tons	\$83.95	<u>7A</u>	<u>11H</u>	<u>8X</u>	<u>View</u>
King	<u>Power Equipment Operators-Underground Sewer & Water</u>	Pavement Breaker	\$78.65	<u>15J</u>	<u>11G</u>	<u>8X</u>	<u>View</u>
King	<u>Power Equipment Operators-Underground Sewer & Water</u>	Pile Driver (other Than Crane Mount)	\$82.88	<u>15J</u>	<u>11G</u>	<u>8X</u>	<u>View</u>
King	<u>Power Equipment Operators-Underground Sewer & Water</u>	Plant Oiler - Asphalt, Crusher	\$82.25	<u>15J</u>	<u>11G</u>	<u>8X</u>	<u>View</u>
King	<u>Power Equipment Operators-Underground Sewer & Water</u>	Posthole Digger, Mechanical	\$78.65	<u>15J</u>	<u>11G</u>	<u>8X</u>	<u>View</u>
King	<u>Power Equipment Operators-Underground Sewer & Water</u>	Power Plant	\$78.65	<u>15J</u>	<u>11G</u>	<u>8X</u>	<u>View</u>
King	<u>Power Equipment Operators-Underground Sewer & Water</u>	Pumps - Water	\$78.65	<u>15J</u>	<u>11G</u>	<u>8X</u>	<u>View</u>
King	<u>Power Equipment Operators-Underground Sewer & Water</u>	Quad 9, Hd 41, D10 And Over	\$83.62	<u>15J</u>	<u>11G</u>	<u>8X</u>	<u>View</u>
King	<u>Power Equipment Operators-Underground Sewer & Water</u>	Quick Tower: no cab, under 100 feet in height base to boom	\$82.88	<u>15J</u>	<u>11G</u>	<u>8X</u>	<u>View</u>
King	<u>Power Equipment Operators-Underground Sewer & Water</u>	Remote Control Operator On Rubber Tired Earth Moving Equipment	\$83.62	<u>15J</u>	<u>11G</u>	<u>8X</u>	<u>View</u>
King	<u>Power Equipment Operators-Underground Sewer & Water</u>	Rigger and Bellman	\$78.95	<u>7A</u>	<u>11H</u>	<u>8X</u>	<u>View</u>
King	<u>Power Equipment Operators-Underground Sewer & Water</u>	Rigger/Signal Person, Bellman(Certified)	\$82.56	<u>7A</u>	<u>11H</u>	<u>8X</u>	<u>View</u>
King	<u>Power Equipment Operators-Underground Sewer & Water</u>	Rollagon	\$83.62	<u>15J</u>	<u>11G</u>	<u>8X</u>	<u>View</u>
King	<u>Power Equipment Operators-Underground Sewer & Water</u>	Roller, Other Than Plant Mix	\$78.65	<u>15J</u>	<u>11G</u>	<u>8X</u>	<u>View</u>
King	<u>Power Equipment Operators-Underground Sewer & Water</u>	Roller, Plant Mix Or Multi-lift Materials	\$82.25	<u>15J</u>	<u>11G</u>	<u>8X</u>	<u>View</u>
King	<u>Power Equipment Operators-Underground Sewer & Water</u>	Roto-mill, Roto-grinder	\$82.88	<u>15J</u>	<u>11G</u>	<u>8X</u>	<u>View</u>
King	<u>Power Equipment Operators-Underground Sewer & Water</u>	Saws - Concrete	\$82.25	<u>15J</u>	<u>11G</u>	<u>8X</u>	<u>View</u>
King	<u>Power Equipment Operators-Underground Sewer & Water</u>	Scraper, Self Propelled Under 45 Yards	\$82.88	<u>15J</u>	<u>11G</u>	<u>8X</u>	<u>View</u>

King	<u>Power Equipment Operators-Underground Sewer & Water</u>	Scrapers - Concrete & Carry All	\$82.25	<u>15J</u>	<u>11G</u>	<u>8X</u>	<u>View</u>
King	<u>Power Equipment Operators-Underground Sewer & Water</u>	Scrapers, Self-propelled: 45 Yards And Over	\$83.62	<u>15J</u>	<u>11G</u>	<u>8X</u>	<u>View</u>
King	<u>Power Equipment Operators-Underground Sewer & Water</u>	Shotcrete/Gunite Equipment	\$78.65	<u>15J</u>	<u>11G</u>	<u>8X</u>	<u>View</u>
King	<u>Power Equipment Operators-Underground Sewer & Water</u>	Shovel, Excavator, Backhoe, Tractors Under 15 Metric Tons	\$82.25	<u>15J</u>	<u>11G</u>	<u>8X</u>	<u>View</u>
King	<u>Power Equipment Operators-Underground Sewer & Water</u>	Shovel, Excavator, Backhoe: Over 30 Metric Tons To 50 Metric Tons	\$83.62	<u>15J</u>	<u>11G</u>	<u>8X</u>	<u>View</u>
King	<u>Power Equipment Operators-Underground Sewer & Water</u>	Shovel, Excavator, Backhoes, Tractors: 15 To 30 Metric Tons	\$82.88	<u>15J</u>	<u>11G</u>	<u>8X</u>	<u>View</u>
King	<u>Power Equipment Operators-Underground Sewer & Water</u>	Shovel, Excavator, Backhoes: Over 50 Metric Tons To 90 Metric Tons	\$84.46	<u>15J</u>	<u>11G</u>	<u>8X</u>	<u>View</u>
King	<u>Power Equipment Operators-Underground Sewer & Water</u>	Shovel, Excavator, Backhoes: Over 90 Metric Tons	\$85.33	<u>15J</u>	<u>11G</u>	<u>8X</u>	<u>View</u>
King	<u>Power Equipment Operators-Underground Sewer & Water</u>	Slipform Pavers	\$83.62	<u>15J</u>	<u>11G</u>	<u>8X</u>	<u>View</u>
King	<u>Power Equipment Operators-Underground Sewer & Water</u>	Spreader, Topsider & Screedman	\$83.62	<u>15J</u>	<u>11G</u>	<u>8X</u>	<u>View</u>
King	<u>Power Equipment Operators-Underground Sewer & Water</u>	Subgrader Trimmer	\$82.88	<u>15J</u>	<u>11G</u>	<u>8X</u>	<u>View</u>
King	<u>Power Equipment Operators-Underground Sewer & Water</u>	Tower Bucket Elevators	\$82.25	<u>15J</u>	<u>11G</u>	<u>8X</u>	<u>View</u>
King	<u>Power Equipment Operators-Underground Sewer & Water</u>	Tower Crane: over 175' through 250' in height, base to boom	\$85.66	<u>7A</u>	<u>11H</u>	<u>8X</u>	<u>View</u>
King	<u>Power Equipment Operators-Underground Sewer & Water</u>	Tower crane: up to 175' in height base to boom	\$84.77	<u>7A</u>	<u>11H</u>	<u>8X</u>	<u>View</u>
King	<u>Power Equipment Operators-Underground Sewer & Water</u>	Tower Cranes: over 250' in height from base to boom	\$86.48	<u>7A</u>	<u>11H</u>	<u>8X</u>	<u>View</u>
King	<u>Power Equipment Operators-Underground Sewer & Water</u>	Transporters, All Track Or Truck Type	\$83.62	<u>15J</u>	<u>11G</u>	<u>8X</u>	<u>View</u>
King	<u>Power Equipment Operators-Underground Sewer & Water</u>	Trenching Machines	\$82.25	<u>15J</u>	<u>11G</u>	<u>8X</u>	<u>View</u>
King	<u>Power Equipment Operators-Underground Sewer & Water</u>	Truck Crane Oiler/Driver: 100 tons and over	\$83.20	<u>7A</u>	<u>11H</u>	<u>8X</u>	<u>View</u>
King	<u>Power Equipment Operators-Underground Sewer & Water</u>	Truck crane oiler/driver: under 100 tons	\$82.56	<u>7A</u>	<u>11H</u>	<u>8X</u>	<u>View</u>
King	<u>Power Equipment Operators-Underground Sewer & Water</u>	Truck Mount Portable Conveyor	\$82.88	<u>15J</u>	<u>11G</u>	<u>8X</u>	<u>View</u>
King	<u>Power Equipment Operators-Underground Sewer & Water</u>	Vac Truck (Vactor Guzzler, Hydro Excavator)	\$82.88	<u>15J</u>	<u>11G</u>	<u>8X</u>	<u>View</u>
King	<u>Power Equipment Operators-Underground Sewer & Water</u>	Welder	\$83.62	<u>15J</u>	<u>11G</u>	<u>8X</u>	<u>View</u>
King	<u>Power Equipment Operators-Underground Sewer & Water</u>	Wheel Tractors, Farmall Type	\$78.65	<u>15J</u>	<u>11G</u>	<u>8X</u>	<u>View</u>
King	<u>Power Equipment Operators-Underground Sewer & Water</u>	Yo Yo Pay Dozer	\$82.88	<u>15J</u>	<u>11G</u>	<u>8X</u>	<u>View</u>
King	<u>Power Line Clearance Tree Trimmers</u>	Journey Level In Charge	\$57.22	<u>5A</u>	<u>4A</u>		<u>View</u>

King	Power Line Clearance Tree Trimmers	Spray Person	\$54.32	5A	4A	View
King	Power Line Clearance Tree Trimmers	Tree Equipment Operator	\$57.22	5A	4A	View
King	Power Line Clearance Tree Trimmers	Tree Trimmer	\$51.18	5A	4A	View
King	Power Line Clearance Tree Trimmers	Tree Trimmer Groundperson	\$38.99	5A	4A	View
King	Refrigeration & Air Conditioning Mechanics	Journey Level	\$93.51	6Z	1G	View
King	Residential Brick Mason	Journey Level	\$69.07	7E	1N	View
King	Residential Carpenters	Journey Level	\$36.44		1	View
King	Residential Cement Masons	Journey Level	\$46.64		1	View
King	Residential Drywall Applicators	Journey Level	\$74.96	15J	4C	View
King	Residential Drywall Tapers	Journey Level	\$36.36		1	View
King	Residential Electricians	Journey Level	\$48.80		1	View
King	Residential Glaziers	Journey Level	\$28.93		1	View
King	Residential Insulation Applicators	Journey Level	\$28.18		1	View
King	Residential Laborers	Journey Level	\$29.73		1	View
King	Residential Marble Setters	Journey Level	\$27.38		1	View
King	Residential Painters	Journey Level	\$23.47		1	View
King	Residential Plumbers & Pipefitters	Journey Level	\$100.69	6Z	1G	View
King	Residential Refrigeration & Air Conditioning Mechanics	Journey Level	\$93.51	6Z	1G	View
King	Residential Sheet Metal Workers	Journey Level	\$96.42	7F	1E	View
King	Residential Soft Floor Layers	Journey Level	\$57.11	5A	3J	View
King	Residential Sprinkler Fitters (Fire Protection)	Journey Level	\$58.26	5C	2R	View
King	Residential Stone Masons	Journey Level	\$69.07	7E	1N	View
King	Residential Terrazzo Workers	Journey Level	\$62.36	7E	1N	View
King	Residential Terrazzo/Tile Finishers	Journey Level	\$24.39		1	View
King	Residential Tile Setters	Journey Level	\$21.04		1	View
King	Roofers	Journey Level	\$61.95	5A	3H	View
King	Roofers	Using Irritable Bituminous Materials	\$64.95	5A	3H	View
King	Sheet Metal Workers	Journey Level (Field or Shop)	\$96.42	7F	1E	View
King	Shipbuilding & Ship Repair	New Construction Boilermaker	\$51.85	7X	4J	View
King	Shipbuilding & Ship Repair	New Construction Carpenter	\$51.85	7X	4J	View
King	Shipbuilding & Ship Repair	New Construction Crane Operator	\$41.83	7V	1	View
King	Shipbuilding & Ship Repair	New Construction Electrician	\$51.85	7X	4J	View
King	Shipbuilding & Ship Repair	New Construction Heat & Frost Insulator	\$87.15	15H	11C	View
King	Shipbuilding & Ship Repair	New Construction Laborer	\$51.85	7X	4J	View
King	Shipbuilding & Ship Repair	New Construction Machinist	\$51.85	7X	4J	View

King	Shipbuilding & Ship Repair	New Construction Operating Engineer	\$41.83	7V	1		View
King	Shipbuilding & Ship Repair	New Construction Painter	\$51.95	7X	4J		View
King	Shipbuilding & Ship Repair	New Construction Pipefitter	\$51.85	7X	4J		View
King	Shipbuilding & Ship Repair	New Construction Rigger	\$51.85	7X	4J		View
King	Shipbuilding & Ship Repair	New Construction Sheet Metal	\$51.85	7X	4J		View
King	Shipbuilding & Ship Repair	New Construction Shipwright	\$51.85	7X	4J		View
King	Shipbuilding & Ship Repair	New Construction Warehouse/Teamster	\$41.83	7V	1		View
King	Shipbuilding & Ship Repair	New Construction Welder / Burner	\$51.85	7X	4J		View
King	Shipbuilding & Ship Repair	Ship Repair Boilermaker	\$51.85	7X	4J		View
King	Shipbuilding & Ship Repair	Ship Repair Carpenter	\$51.85	7X	4J		View
King	Shipbuilding & Ship Repair	Ship Repair Crane Operator	\$45.06	7Y	4K		View
King	Shipbuilding & Ship Repair	Ship Repair Electrician	\$51.85	7X	4J		View
King	Shipbuilding & Ship Repair	Ship Repair Heat & Frost Insulator	\$87.15	15H	11C		View
King	Shipbuilding & Ship Repair	Ship Repair Laborer	\$51.85	7X	4J		View
King	Shipbuilding & Ship Repair	Ship Repair Machinist	\$51.85	7X	4J		View
King	Shipbuilding & Ship Repair	Ship Repair Operating Engineer	\$45.06	7Y	4K		View
King	Shipbuilding & Ship Repair	Ship Repair Painter	\$51.95	7X	4J		View
King	Shipbuilding & Ship Repair	Ship Repair Pipefitter	\$51.85	7X	4J		View
King	Shipbuilding & Ship Repair	Ship Repair Rigger	\$51.85	7X	4J		View
King	Shipbuilding & Ship Repair	Ship Repair Sheet Metal	\$51.85	7X	4J		View
King	Shipbuilding & Ship Repair	Ship Repair Shipwright	\$51.85	7X	4J		View
King	Shipbuilding & Ship Repair	Ship Repair Warehouse / Teamster	\$45.06	7Y	4K		View
King	Sign Makers & Installers (Electrical)	Journey Level	\$58.04	0	1		View
King	Sign Makers & Installers (Non-Electrical)	Journey Level	\$37.08	0	1		View
King	Soft Floor Layers	Journey Level	\$66.32	15J	4C		View
King	Solar Controls For Windows	Journey Level	\$15.74		1		View
King	Sprinkler Fitters (Fire Protection)	Journey Level	\$93.99	5C	1X		View
King	Stage Rigging Mechanics (Non Structural)	Journey Level	\$15.74		1		View
King	Stone Masons	Journey Level	\$69.07	7E	1N		View
King	Street And Parking Lot Sweeper Workers	Journey Level	\$19.09		1		View
King	Surveyors	Assistant Construction Site Surveyor	\$82.56	7A	11H	8X	View
King	Surveyors	Chainman	\$78.95	7A	11H	8X	View
King	Surveyors	Construction Site Surveyor	\$83.95	7A	11H	8X	View
King	Surveyors	Drone Operator (when used in conjunction with survey work only)	\$78.95	7A	11H	8X	View
King	Surveyors	Ground Penetrating Radar Operator	\$78.95	7A	11H	8X	View
King	Telecommunication Technicians	Journey Level	\$63.38	7E	1E		View

King	Telephone Line Construction - Outside	Cable Splicer	\$40.11	5A	2B		View
King	Telephone Line Construction - Outside	Hole Digger/Ground Person	\$26.67	5A	2B		View
King	Telephone Line Construction - Outside	Telephone Equipment Operator (Light)	\$33.49	5A	2B		View
King	Telephone Line Construction - Outside	Telephone Lineperson	\$37.90	5A	2B		View
King	Terrazzo Workers	Journey Level	\$62.36	7E	1N		View
King	Tile Setters	Journey Level	\$62.36	7E	1N		View
King	Tile, Marble & Terrazzo Finishers	Finisher	\$53.19	7E	1N		View
King	Traffic Control Stripers	Journey Level	\$89.54	15L	1K		View
King	Truck Drivers	Asphalt Mix Over 16 Yards	\$74.95	15J	11M	8L	View
King	Truck Drivers	Asphalt Mix To 16 Yards	\$74.02	15J	11M	8L	View
King	Truck Drivers	Dump Truck	\$74.02	15J	11M	8L	View
King	Truck Drivers	Dump Truck & Trailer	\$74.95	15J	11M	8L	View
King	Truck Drivers	Other Trucks	\$74.95	15J	11M	8L	View
King	Truck Drivers - Ready Mix	Transit Mix	\$74.95	15J	11M	8L	View
King	Well Drillers & Irrigation Pump Installers	Irrigation Pump Installer	\$17.71		1		View
King	Well Drillers & Irrigation Pump Installers	Oiler	\$15.74		1		View
King	Well Drillers & Irrigation Pump Installers	Well Driller	\$18.00		1		View

Benefit Code Key – Effective 8/31/2023 thru 3/1/2024

Overtime Codes

Overtime calculations are based on the hourly rate actually paid to the worker. On public works projects, the hourly rate must be not less than the prevailing rate of wage minus the hourly rate of the cost of fringe benefits actually provided for the worker.

1. ALL HOURS WORKED IN EXCESS OF EIGHT (8) HOURS PER DAY OR FORTY (40) HOURS PER WEEK SHALL BE PAID AT ONE AND ONE-HALF TIMES THE HOURLY RATE OF WAGE.
 - B. All hours worked on Saturdays shall be paid at one and one-half times the hourly rate of wage. All hours worked on Sundays and holidays shall be paid at double the hourly rate of wage.
 - C. The first two (2) hours after eight (8) regular hours Monday through Friday and the first ten (10) hours on Saturday shall be paid at one and one-half times the hourly rate of wage. All other overtime hours and all hours worked on Sundays and holidays shall be paid at double the hourly rate of wage.
 - D. The first two (2) hours before or after a five-eight (8) hour workweek day or a four-ten (10) hour workweek day and the first eight (8) hours worked the next day after either workweek shall be paid at one and one-half times the hourly rate of wage. All additional hours worked and all worked on Sundays and holidays shall be paid at double the hourly rate of wage.
 - E. The first two (2) hours after eight (8) regular hours Monday through Friday and the first eight (8) hours on Saturday shall be paid at one and one-half times the hourly rate of wage. All other hours worked Monday through Saturday, and all hours worked on Sundays and holidays shall be paid at double the hourly rate of wage.
 - F. The first two (2) hours after eight (8) regular hours Monday through Friday and the first ten (10) hours on Saturday shall be paid at one and one-half times the hourly rate of wage. All other overtime hours worked, except Labor Day, shall be paid at double the hourly rate of wage. All hours worked on Labor Day shall be paid at three times the hourly rate of wage.
 - G. The first ten (10) hours worked on Saturdays and the first ten (10) hours worked on a fifth calendar weekday in a four-ten hour schedule, shall be paid at one and one-half times the hourly rate of wage. All hours worked in excess of ten (10) hours per day Monday through Saturday and all hours worked on Sundays and holidays shall be paid at double the hourly rate of wage.
 - H. All hours worked on Saturdays (except makeup days if work is lost due to inclement weather conditions or equipment breakdown) shall be paid at one and one-half times the hourly rate of wage. All hours worked Monday through Saturday over twelve (12) hours and all hours worked on Sundays and holidays shall be paid at double the hourly rate of wage.
 - I. All hours worked on Sundays and holidays shall also be paid at double the hourly rate of wage.
 - J. The first two (2) hours after eight (8) regular hours Monday through Friday and the first ten (10) hours on Saturday shall be paid at one and one-half times the hourly rate of wage. All hours worked over ten (10) hours Monday through Saturday, Sundays and holidays shall be paid at double the hourly rate of wage.
 - K. All hours worked on Saturdays and Sundays shall be paid at one and one-half times the hourly rate of wage. All hours worked on holidays shall be paid at double the hourly rate of wage.
 - M. All hours worked on Saturdays (except makeup days if work is lost due to inclement weather conditions) shall be paid at one and one-half times the hourly rate of wage. All hours worked on Sundays and holidays shall be paid at double the hourly rate of wage.
 - N. All hours worked on Saturdays (except makeup days) shall be paid at one and one-half times the hourly rate of wage. All hours worked on Sundays and holidays shall be paid at double the hourly rate of wage.

Overtime Codes Continued

1. O. The first ten (10) hours worked on Saturday shall be paid at one and one-half times the hourly rate of wage. All hours worked on Sundays, holidays and after twelve (12) hours, Monday through Friday and after ten (10) hours on Saturday shall be paid at double the hourly rate of wage.
- P. All hours worked on Saturdays (except makeup days if circumstances warrant) and Sundays shall be paid at one and one-half times the hourly rate of wage. All hours worked on holidays shall be paid at double the hourly rate of wage.
- Q. The first two (2) hours after eight (8) regular hours Monday through Friday and up to ten (10) hours worked on Saturdays shall be paid at one and one-half times the hourly rate of wage. All hours worked in excess of ten (10) hours per day Monday through Saturday and all hours worked on Sundays and holidays (except Christmas day) shall be paid at double the hourly rate of wage. All hours worked on Christmas day shall be paid at two and one-half times the hourly rate of wage.
- R. All hours worked on Sundays and holidays shall be paid at two times the hourly rate of wage.
- U. All hours worked on Saturdays shall be paid at one and one-half times the hourly rate of wage. All hours worked on Sundays and holidays (except Labor Day) shall be paid at two times the hourly rate of wage. All hours worked on Labor Day shall be paid at three times the hourly rate of wage.
- V. All hours worked on Sundays and holidays (except Thanksgiving Day and Christmas day) shall be paid at one and one-half times the hourly rate of wage. All hours worked on Thanksgiving Day and Christmas day shall be paid at double the hourly rate of wage.
- W. All hours worked on Saturdays and Sundays (except make-up days due to conditions beyond the control of the employer) shall be paid at one and one-half times the hourly rate of wage. All hours worked on holidays shall be paid at double the hourly rate of wage.
- X. The first four (4) hours after eight (8) regular hours Monday through Friday and the first twelve (12) hours on Saturday shall be paid at one and one-half times the hourly rate of wage. All hours worked over twelve (12) hours Monday through Saturday, Sundays and holidays shall be paid at double the hourly rate of wage. When holiday falls on Saturday or Sunday, the day before Saturday, Friday, and the day after Sunday, Monday, shall be considered the holiday and all work performed shall be paid at double the hourly rate of wage.
- Y. All hours worked outside the hours of 5:00 am and 5:00 pm (or such other hours as may be agreed upon by any employer and the employee) and all hours worked in excess of eight (8) hours per day (10 hours per day for a 4 x 10 workweek) and on Saturdays and holidays (except labor day) shall be paid at one and one-half times the hourly rate of wage. (except for employees who are absent from work without prior approval on a scheduled workday during the workweek shall be paid at the straight-time rate until they have worked 8 hours in a day (10 in a 4 x 10 workweek) or 40 hours during that workweek.) All hours worked Monday through Saturday over twelve (12) hours and all hours worked on Sundays and Labor Day shall be paid at double the hourly rate of wage.
- Z. All hours worked on Saturdays and Sundays shall be paid at one and one-half times the hourly rate of wage. All hours worked on holidays shall be paid the straight time rate of pay in addition to holiday pay.

Overtime Codes Continued

2. ALL HOURS WORKED IN EXCESS OF EIGHT (8) HOURS PER DAY OR FORTY (40) HOURS PER WEEK SHALL BE PAID AT ONE AND ONE-HALF TIMES THE HOURLY RATE OF WAGE.
- B. All hours worked on holidays shall be paid at one and one-half times the hourly rate of wage.
 - F. The first eight (8) hours worked on holidays shall be paid at the straight hourly rate of wage in addition to the holiday pay. All hours worked in excess of eight (8) hours on holidays shall be paid at double the hourly rate of wage.
 - M. This code appears to be missing. All hours worked on Saturdays, Sundays and holidays shall be paid at double the hourly rate of wage.
 - R. All hours worked on Sundays and holidays and all hours worked over sixty (60) in one week shall be paid at double the hourly rate of wage.
 - U. All hours worked on Saturdays shall be paid at one and one-half times the hourly rate of wage. All hours worked over 12 hours in a day or on Sundays and holidays shall be paid at double the hourly rate of wage.
3. ALL HOURS WORKED IN EXCESS OF EIGHT (8) HOURS PER DAY OR FORTY (40) HOURS PER WEEK SHALL BE PAID AT ONE AND ONE-HALF TIMES THE HOURLY RATE OF WAGE.
- F. All hours worked on Saturday shall be paid at one and one-half times the hourly rate of wage. All hours worked on Sunday shall be paid at two times the hourly rate of wage. All hours worked on paid holidays shall be paid at two and one-half times the hourly rate of wage including holiday pay.
 - H. All work performed on Sundays between March 16th and October 14th and all Holidays shall be compensated for at two (2) times the regular rate of pay. Work performed on Sundays between October 15th and March 15th shall be compensated at one and one half (1-1/2) times the regular rate of pay.
 - J. All hours worked between the hours of 10:00 pm and 5:00 am, Monday through Friday, and all hours worked on Saturdays shall be paid at a one and one-half times the hourly rate of wage. All hours worked on Sundays and holidays shall be paid at double the hourly rate of wage.
 - K. Work performed in excess of eight (8) hours of straight time per day, or ten (10) hours of straight time per day when four ten (10) hour shifts are established, or forty (40) hours of straight time per week, Monday through Friday, or outside the normal 5 am to 6pm shift, and all work on Saturdays shall be paid at one and one-half times the hourly rate of wage. All work performed after 6:00 pm Saturday to 5:00 am Monday and Holidays, and all hours worked in excess of twelve (12) hours in a single shift shall be paid at double the hourly rate of wage.

After an employee has worked eight (8) hours at an applicable overtime rate, all additional hours shall be at the applicable overtime rate until such time as the employee has had a break of eight (8) hours or more. When an employee returns to work without at least eight (8) hours time off since their previous shift, all such time shall be a continuation of shift and paid at the applicable overtime rate until he/she shall have the eight (8) hours rest period.

Overtime Codes Continued

4. ALL HOURS WORKED IN EXCESS OF EIGHT (8) HOURS PER DAY OR FORTY (40) HOURS PER WEEK SHALL BE PAID AT ONE AND ONE-HALF TIMES THE HOURLY RATE OF WAGE.

- A. All hours worked in excess of eight (8) hours per day or forty (40) hours per week shall be paid at double the hourly rate of wage. All hours worked on Saturdays, Sundays and holidays shall be paid at double the hourly rate of wage
- C. On Monday through Friday, the first four (4) hours of overtime after eight (8) hours of straight time work shall be paid at one and one half (1-1/2) times the straight time rate of pay, unless a four (4) day ten (10) hour workweek has been established. On a four (4) day ten (10) hour workweek scheduled Monday through Thursday, or Tuesday through Friday, the first two (2) hours of overtime after ten (10) hours of straight time work shall be paid at one and one half (1-1/2) times the straight time rate of pay. On Saturday, the first twelve (12) hours of work shall be paid at one and one half (1-1/2) times the straight time rate of pay, except that if the job is down on Monday through Friday due to weather conditions or other conditions outside the control of the employer, the first ten (10) hours on Saturday may be worked at the straight time rate of pay. All hours worked over twelve (12) hours in a day and all hours worked on Sunday and Holidays shall be paid at two (2) times the straight time rate of pay.
- D. All hours worked in excess of eight (8) hours per day or forty (40) hours per week shall be paid at double the hourly rate of wage. All hours worked on Saturday, Sundays and holidays shall be paid at double the hourly rate of pay. Rates include all members of the assigned crew.

EXCEPTION:

On all multipole structures and steel transmission lines, switching stations, regulating, capacitor stations, generating plants, industrial plants, associated installations and substations, except those substations whose primary function is to feed a distribution system, will be paid overtime under the following rates:

The first two (2) hours after eight (8) regular hours Monday through Friday of overtime on a regular workday, shall be paid at one and one-half times the hourly rate of wage. All hours in excess of ten (10) hours will be at two (2) times the hourly rate of wage. The first eight (8) hours worked on Saturday will be paid at one and one-half (1-1/2) times the hourly rate of wage. All hours worked in excess of eight (8) hours on Saturday, and all hours worked on Sundays and holidays will be at the double the hourly rate of wage.

All overtime eligible hours performed on the above described work that is energized, shall be paid at the double the hourly rate of wage.

- E. The first two (2) hours after eight (8) regular hours Monday through Friday and the first eight (8) hours on Saturday shall be paid at one and one-half times the hourly rate of wage. All other hours worked Monday through Saturday, and all hours worked on Sundays and holidays shall be paid at double the hourly rate of wage.

On a four-day, ten-hour weekly schedule, either Monday thru Thursday or Tuesday thru Friday schedule, all hours worked after ten shall be paid at double the hourly rate of wage. The Monday or Friday not utilized in the normal four-day, ten hour work week, and Saturday shall be paid at one and one half (1½) times the regular shift rate for the first eight (8) hours. All other hours worked Monday through Saturday, and all hours worked on Sundays and holidays shall be paid at double the hourly rate of wage.
- G. All hours worked on Saturdays shall be paid at one and one-half times the hourly rate of wage. All hours worked Monday through Saturday over twelve (12) hours and all hours worked on Sundays and holidays shall be paid at double the hourly rate of wage.
- I. The First eight (8) hours worked on Saturdays shall be paid at one and one-half times the hourly rate of wage. All hours worked in excess of eight (8) per day on Saturdays shall be paid at double the hourly rate of wage. All hours worked on Sundays and holidays shall be paid at double the hourly rate of wage.

Overtime Codes Continued

4. J. The first eight (8) hours worked on a Saturday shall be paid at one and one-half times the hourly rate of wage. All hours worked in excess of eight (8) hours on a Saturday shall be paid at double the hourly rate of wage. All hours worked over twelve (12) in a day, and all hours worked on Sundays and Holidays shall be paid at double the hourly rate of wage.
- K. All hours worked on a Saturday shall be paid at one and one-half times the hourly rate of wage, so long as Saturday is the sixth consecutive day worked. All hours worked over twelve (12) in a day Monday through Saturday, and all hours worked on Sundays and Holidays shall be paid at double the hourly rate of wage.
- L. The first twelve (12) hours worked on a Saturday shall be paid at one and one-half times the hourly rate of wage. All hours worked on a Saturday in excess of twelve (12) hours shall be paid at double the hourly rate of pay. All hours worked over twelve (12) in a day Monday through Friday, and all hours worked on Sundays shall be paid at double the hourly rate of wage. All hours worked on a holiday shall be paid at one and one-half times the hourly rate of wage, except that all hours worked on Labor Day shall be paid at double the hourly rate of pay.
- S. On a four (4) day ten (10) hour workweek scheduled Monday through Thursday, or Tuesday through Friday, work performed in excess of (10) hours shall be paid at one and one half (1-1/2) times the hourly rate of pay. On Monday through Friday, work performed outside the normal work hours of 6:00 a.m. and 6:00 p.m. shall be paid at one and one-half (1-1/2) times the straight time rate, (except for special shifts or multiple shift operations).
- All hours worked on Saturdays shall be paid at one and one-half times the hourly rate of wage. All work performed on Sundays and holidays shall be paid at double the hourly rate of wage. When an employee returns to work without at least eight (8) hours time off since their previous shift, all such time shall be a continuation of shift and paid at the applicable overtime rate until such time as the employee has had a break of eight (8) hours.
- Multiple Shift Operations: When the first shift of a multiple shift (a two or three shift) operation is started at the basic straight time rate or at a specific overtime rate, all shifts of that day's operation shall be completed at that rate. Special Shifts: The Special Shift Premium is the basic hourly rate of pay plus \$2.00 an hour. When due to conditions beyond the control of the employer or when an owner (not acting as the contractor), a government agency or the contract specifications require more than four (4) hours of a special shift can only be performed outside the normal 6am to 6pm shift then the special shift premium will be applied to the basic straight time for the entire shift. When an employee works on a special shift, they shall be paid the special shift premium for each hour worked unless they are in overtime or double-time status. (For example, the special shift premium does not waive the overtime requirements for work performed on Saturday or Sunday).
- U. The first four (4) hours after eight (8) regular hours Monday through Friday and the first twelve (12) hours on Saturday shall be paid at one and one-half times the hourly rate of wage. (Except on makeup days if work is lost due to inclement weather, then the first eight (8) hours on Saturday may be paid the regular rate.) All hours worked over twelve (12) hours Monday through Saturday, and all hours worked on Sundays and holidays shall be paid at double the hourly rate of wage.

Overtime Codes Continued

4. V. Work performed in excess of ten (10) hours of straight time per day when four ten (10) hour shifts are established or outside the normal shift (5 am to 6pm), and all work on Saturdays, except for make-up days shall be paid at time and one-half (1 ½) the straight time rate.

In the event the job is down due to weather conditions, then Saturday may, be worked as a voluntary make-up day at the straight time rate. However, Saturday shall not be utilized as a make-up day when a holiday falls on Friday. All work performed on Sundays and holidays and work in excess of twelve (12) hours per day shall be paid at double (2x) the straight time rate of pay.

After an employee has worked eight (8) hours at an applicable overtime rate, all additional hours shall be at the applicable overtime rate until such time as the employee has had a break of eight (8) hours.

When an employee returns to work without a break of eight (8) hours since their previous shift, all such time shall be a continuation of shift and paid at the applicable overtime rate until such time as the employee has had a break of eight (8) hours.

- X. All hours worked on Saturdays shall be paid at one and one-half times the hourly rate of wage. All hours worked on Sundays and holidays shall be paid at double the hourly rate of wage. Work performed outside the normal shift of 6 am to 6pm shall be paid at one and one-half the straight time rate, (except for special shifts or three shift operations). All work performed on Sundays and holidays shall be paid at double the hourly rate of wage. Shifts may be established when considered necessary by the Employer.

The Employer may establish shifts consisting of eight (8) or ten (10) hours of work (subject to WAC 296-127-022), that shall constitute a normal forty (40) hour work week. The Employer can change from a 5-eight to a 4-ten hour schedule or back to the other. All hours of work on these shifts shall be paid for at the straight time hourly rate. Work performed in excess of eight hours (or ten hours per day (subject to WAC 296-127-022) shall be paid at one and one-half the straight time rate.

When due to conditions beyond the control of the Employer, or when contract specifications require that work can only be performed outside the regular day shift, then by mutual agreement a special shift may be worked at the straight time rate, eight (8) hours work for eight (8) hours pay. The starting time shall be arranged to fit such conditions of work.

When an employee returns to work without at a break of eight (8) hours since their previous shift, all such time shall be a continuation of shift and paid at the applicable overtime rate until such time as the employee has had a break of eight (8) hours.

11. ALL HOURS WORKED IN EXCESS OF EIGHT (8) HOURS PER DAY OR FORTY (40) HOURS PER WEEK SHALL BE PAID AT ONE AND ONE-HALF TIMES THE HOURLY RATE OF WAGE.

- B After an employee has worked eight (8) hours, all additional hours worked shall be paid at the applicable overtime rate until such time as the employee has had a break of eight (8) hours or more.

- C The first two (2) hours after eight (8) regular hours Monday through Friday and the first eight (8) hours on Saturday shall be paid at one and one-half times the hourly rate of wage. All other overtime hours worked, except Labor Day, and all hours on Sunday shall be paid at double the hourly rate of wage. All hours worked on Labor Day shall be paid at three times the hourly rate of wage. All non-overtime and non-holiday hours worked between 4:00 pm and 5:00 am, Monday through Friday, shall be paid at a premium rate of 15% over the hourly rate of wage.

Overtime Codes Continued

11. D. All hours worked on Saturdays and holidays shall be paid at one and one-half times the hourly rate of wage. All hours worked on Sundays shall be paid at double the hourly rate of wage.
- After an employee has worked eight (8) hours, all additional hours worked shall be paid at the applicable overtime rate until such time as the employee has had a break of eight (8) hours or more.
- E. The first two (2) hours after eight (8) regular hours Monday through Friday, the first ten (10) hours on Saturday, and the first ten (10) hours worked on Holidays shall be paid at one and one-half times the hourly rate of wage. All hours worked over ten (10) hours Monday through Saturday, and Sundays shall be paid at double the hourly rate of wage.
- After an employee has worked eight (8) hours, all additional hours worked shall be paid at the applicable overtime rate until such time as the employee has had a break of eight (8) hours or more.
- F. The first two (2) hours after eight (8) regular hours Monday through Friday and the first eight (8) hours on Saturday shall be paid at one and one-half times the hourly rate of wage. All other hours worked Monday through Saturday, and all hours worked on Sundays and holidays shall be paid at double the hourly rate of wage.
- On a four-day, ten-hour weekly schedule, either Monday thru Thursday or Tuesday thru Friday schedule, all hours worked after ten shall be paid at double the hourly rate of wage. The Monday or Friday not utilized in the normal four-day, ten hour work week, and Saturday shall be paid at one-half times the hourly rate of wage for the first eight (8) hours. All other hours worked Monday through Saturday, and all hours worked on Sundays and holidays shall be paid at double the hourly rate of wage.
- G. Work performed in excess of eight (8) hours of straight time per day, or ten (10) hours of straight time per day when four ten (10) hour shifts are established, or forty (40) hours of straight time per week, Monday through Friday, or outside the normal 5 am to 6pm shift, and all work on Saturdays shall be paid at one and one-half times the hourly rate of wage.
- All work performed after 6:00 pm Saturday to 5:00 am Monday and Holidays, and all hours worked in excess of twelve (12) hours in a single shift shall be paid at double the hourly rate of wage.
- After an employee has worked eight (8) hours at an applicable overtime rate, all additional hours shall be at the applicable overtime rate until such time as the employee has had a break of nine (9) hours or more. When an employee returns to work without at least nine (9) hours time off since their previous shift, all such time shall be a continuation of shift and paid at the applicable overtime rate until he/she shall have the nine (9) hours rest period.
- H. Work performed in excess of eight (8) hours of straight time per day, or ten (10) hours of straight time per day when four ten (10) hour shifts are established, or forty (40) hours of straight time per week, Monday through Friday, or outside the normal 5 am to 6pm shift, and all work on Saturdays shall be paid at one and one-half times the hourly rate of wage.
- All work performed after 6:00 pm Saturday to 5:00 am Monday and Holidays, and all hours worked in excess of twelve (12) hours in a single shift shall be paid at double the hourly rate of wage.
- After an employee has worked eight (8) hours at an applicable overtime rate, all additional hours shall be at the applicable overtime rate until such time as the employee has had a break of ten (10) hours or more. When an employee returns to work without at least ten (10) hours time off since their previous shift, all such time shall be a continuation of shift and paid at the applicable overtime rate until he/she shall have the ten (10) hours rest period.

Overtime Codes Continued

11. J. All hours worked on holidays shall be paid at double the hourly rate of wage.
- K. On Monday through Friday hours worked outside 4:00 am and 5:00 pm, and the first two (2) hours after eight (8) hours worked shall be paid at one and one-half times the hourly rate. All hours worked over 10 hours per day Monday through Friday, and all hours worked on Saturdays, Sundays, and Holidays worked shall be paid at double the hourly rate of wage.
- L. An employee working outside 5:00 am and 5:00 pm shall receive an additional two dollar (\$2.00) per hour for all hours worked that shift. All hours worked on holidays shall be paid at one and one-half times the hourly rate of wage. All hours worked on holidays shall be paid at one and one-half times the hourly rate of wage.
- M. On Monday through Friday, the first four (4) hours of overtime after eight (8) hours of straight time work shall be paid at one and one half (1-1/2) times the straight time rate of pay, unless a four (4) day ten (10) hour workweek has been established. On a four (4) day ten (10) hour workweek scheduled Monday through Thursday, or Tuesday through Friday, the first two (2) hours of overtime after ten (10) hours of straight time work shall be paid at one and one half (1-1/2) times the straight time rate of pay.
- Work performed outside the normal work hours of 5:00 a.m. and 6:00 p.m. shall be paid at one and one-half (1-1/2) times the straight time rate, (except for special shifts or multiple shift operations). When the first shift of a multiple shift (a two or three shift) operation is started at the basic straight time rate or at a specific overtime rate, all shifts of that day's operation shall be completed at that rate. When due to conditions beyond the control of the Employer or when contract specifications require that work can only be performed outside the regular day shift of 5:00 am to 6:00 pm, then a special shift may be worked at the straight time rate, plus the shift pay premium when applicable. The starting time of work will be arranged to fit such conditions of work. Such shift shall consist of eight (8) hours work for eight (8) hours pay or ten (10) hours work for ten (10) hours pay for four ten shifts.
- On Saturday, the first twelve (12) hours of work shall be paid at one and one half (1-1/2) times the straight time rate of pay. All work performed after 6:00 pm Saturday to 5:00 am Monday, all work performed over twelve (12) hours, and all work performed on holidays shall be paid at double the straight time rate of pay.
- Shift Pay Premium: In an addition to any overtime already required, all hours worked between the hours of 6:00 pm and 5:00 am shall receive an additional two dollars (\$2.00) per hour.
- N. All work performed over twelve hours in a shift and all work performed on Sundays and Holidays shall be paid at double the straight time rate.
- Any time worked over eight (8) hours on Saturday shall be paid double the straight time rate, except employees assigned to work six 10-hour shifts per week shall be paid double the straight time rate for any time worked on Saturday over 10 hours.
- O. All work performed on Saturdays, Sundays, and Holidays shall be paid at one and one half (1-1/2) times the straight time rate of pay.

Benefit Code Key – Effective 8/31/2023 thru 3/1/2024

Holiday Codes

5. A. Holidays: New Year's Day, Memorial Day, Independence Day, Labor Day, Thanksgiving Day, Friday after Thanksgiving Day, and Christmas Day (7).
- B. Holidays: New Year's Day, Memorial Day, Independence Day, Labor Day, Thanksgiving Day, Friday after Thanksgiving Day, the day before Christmas, and Christmas Day (8).
- C. Holidays: New Year's Day, Presidents' Day, Memorial Day, Independence Day, Labor Day, Thanksgiving Day, the Friday after Thanksgiving Day, And Christmas Day (8).
- D. Holidays: New Year's Day, Memorial Day, Independence Day, Labor Day, Thanksgiving Day, the Friday and Saturday after Thanksgiving Day, And Christmas Day (8).
- H. Holidays: New Year's Day, Memorial Day, Independence Day, Thanksgiving Day, the Day after Thanksgiving Day, And Christmas (6).
- I. Holidays: New Year's Day, Memorial Day, Independence Day, Labor Day, Thanksgiving Day, and Christmas Day (6).
- K. Holidays: New Year's Day, Presidents' Day, Memorial Day, Independence Day, Labor Day, Thanksgiving Day, Friday After Thanksgiving Day, The Day Before Christmas, And Christmas Day (9).
- L. Holidays: New Year's Day, Martin Luther King Jr. Day, Memorial Day, Independence Day, Labor Day, Thanksgiving Day, Friday after Thanksgiving Day, And Christmas Day (8).
- N. Holidays: New Year's Day, Presidents' Day, Memorial Day, Independence Day, Labor Day, Veterans' Day, Thanksgiving Day, The Friday After Thanksgiving Day, And Christmas Day (9).
- P. Holidays: New Year's Day, Memorial Day, Independence Day, Labor Day, Thanksgiving Day, Friday And Saturday After Thanksgiving Day, The Day Before Christmas, And Christmas Day (9). If A Holiday Falls On Sunday, The Following Monday Shall Be Considered As A Holiday.
- Q. Paid Holidays: New Year's Day, Memorial Day, Independence Day, Labor Day, Thanksgiving Day, and Christmas Day (6).
- R. Paid Holidays: New Year's Day, Memorial Day, Independence Day, Labor Day, Thanksgiving Day, Day After Thanksgiving Day, One-Half Day Before Christmas Day, And Christmas Day. (7 1/2).
- S. Paid Holidays: New Year's Day, Presidents' Day, Memorial Day, Independence Day, Labor Day, Thanksgiving Day, And Christmas Day (7).
- Z. Holidays: New Year's Day, Memorial Day, Independence Day, Labor Day, Veterans Day, Thanksgiving Day, the Friday after Thanksgiving Day, And Christmas Day (8).
6. G. Paid Holidays: New Year's Day, Martin Luther King Jr. Day, Presidents' Day, Memorial Day, Independence Day, Labor Day, Veterans' Day, Thanksgiving Day, the Friday after Thanksgiving Day, Christmas Day, and Christmas Eve Day (11).
- H. Paid Holidays: New Year's Day, New Year's Eve Day, Memorial Day, Independence Day, Labor Day, Thanksgiving Day, Friday After Thanksgiving Day, Christmas Day, The Day After Christmas, And A Floating Holiday (10).

Holiday Codes Continued

6. T. Paid Holidays: New Year's Day, Presidents' Day, Memorial Day, Independence Day, Labor Day, Thanksgiving Day, The Friday After Thanksgiving Day, The Last Working Day Before Christmas Day, And Christmas Day (9).
- Z. Holidays: New Year's Day, Memorial Day, Independence Day, Labor Day, Thanksgiving Day, Friday after Thanksgiving Day, And Christmas Day (7). If a holiday falls on Saturday, the preceding Friday shall be considered as the holiday. If a holiday falls on Sunday, the following Monday shall be considered as the holiday.
7. A. Holidays: New Year's Day, Memorial Day, Independence Day, Labor Day, Thanksgiving Day, the Friday and Saturday after Thanksgiving Day, And Christmas Day (8). Any Holiday Which Falls On A Sunday Shall Be Observed As A Holiday On The Following Monday. If any of the listed holidays falls on a Saturday, the preceding Friday shall be a regular work day.
- B. Holidays: New Year's Day, Memorial Day, Independence Day, Labor Day, Thanksgiving Day, the Friday and Saturday after Thanksgiving Day, And Christmas Day (8). Any holiday which falls on a Sunday shall be observed as a holiday on the following Monday. Any holiday which falls on a Saturday shall be observed as a holiday on the preceding Friday.
- C. Holidays: New Year's Day, Martin Luther King Jr. Day, Memorial Day, Independence Day, Labor Day, Thanksgiving Day, the Friday after Thanksgiving Day, And Christmas Day (8). Any holiday which falls on a Sunday shall be observed as a holiday on the following Monday. Any holiday which falls on a Saturday shall be observed as a holiday on the preceding Friday.
- D. Paid Holidays: New Year's Day, Memorial Day, Independence Day, Labor Day, Veteran's Day, Thanksgiving Day, the Friday after Thanksgiving Day, And Christmas Day (8). Unpaid Holidays: President's Day. Any paid holiday which falls on a Sunday shall be observed as a holiday on the following Monday. Any paid holiday which falls on a Saturday shall be observed as a holiday on the preceding Friday.
- E. Holidays: New Year's Day, Memorial Day, Independence Day, Labor Day, Thanksgiving Day, the Friday after Thanksgiving Day, And Christmas Day (7). Any holiday which falls on a Sunday shall be observed as a holiday on the following Monday. Any holiday which falls on a Saturday shall be observed as a holiday on the preceding Friday.
- F. Holidays: New Year's Day, Memorial Day, Independence Day, Labor Day, Thanksgiving Day, the Friday after Thanksgiving Day, the last working day before Christmas day and Christmas day (8). Any holiday which falls on a Sunday shall be observed as a holiday on the following Monday. Any holiday which falls on a Saturday shall be observed as a holiday on the preceding Friday.
- G. Holidays: New Year's Day, Memorial Day, Independence Day, Labor Day, Thanksgiving Day, and Christmas Day (6). Any holiday which falls on a Sunday shall be observed as a holiday on the following Monday.
- H. Holidays: New Year's Day, Martin Luther King Jr. Day, Independence Day, Memorial Day, Labor Day, Thanksgiving Day, the Friday after Thanksgiving Day, the Last Working Day before Christmas Day and Christmas Day (9). Any holiday which falls on a Sunday shall be observed as a holiday on the following Monday. Any holiday which falls on a Saturday shall be observed as a holiday on the preceding Friday.
- I. Holidays: New Year's Day, President's Day, Independence Day, Memorial Day, Labor Day, Thanksgiving Day, The Friday After Thanksgiving Day, The Day Before Christmas Day And Christmas Day (9). Any holiday which falls on a Sunday shall be observed as a holiday on the following Monday. Any holiday which falls on a Saturday shall be observed as a holiday on the preceding Friday.

Holiday Codes Continued

7. J. Holidays: New Year's Day, Independence Day, Memorial Day, Labor Day, Thanksgiving Day and Christmas Day (6). Any holiday which falls on a Sunday shall be observed as a holiday on the following Monday. Any holiday which falls on a Saturday shall be observed as a holiday on the preceding Friday.
- K. Holidays: New Year's Day, Memorial Day, Independence Day, Thanksgiving Day, the Friday and Saturday after Thanksgiving Day, And Christmas Day (8). Any holiday which falls on a Sunday shall be observed as a holiday on the following Monday. Any holiday which falls on a Saturday shall be observed as a holiday on the preceding Friday.
- L. Holidays: New Year's Day, Memorial Day, Labor Day, Independence Day, Thanksgiving Day, the Last Work Day before Christmas Day, And Christmas Day (7). Any holiday which falls on a Sunday shall be observed as a holiday on the following Monday. Any holiday which falls on a Saturday shall be observed as a holiday on the preceding Friday.
- N. Holidays: New Year's Day, Memorial Day, Independence Day, Labor Day, Thanksgiving Day, the Friday after Thanksgiving Day, And Christmas Day (7). Any holiday which falls on a Sunday shall be observed as a holiday on the following Monday. When Christmas falls on a Saturday, the preceding Friday shall be observed as a holiday.
- P. Holidays: New Year's Day, Memorial Day, Independence Day, Labor Day, Thanksgiving Day, Friday after Thanksgiving Day, And Christmas Day (7). Any holiday which falls on a Sunday shall be observed as a holiday on the following Monday.
- Q. Holidays: New Year's Day, Memorial Day, Independence Day, Labor Day, Thanksgiving Day, the Friday after Thanksgiving Day, the Last Working Day before Christmas Day and Christmas Day (8). Any holiday which falls on a Sunday shall be observed as a holiday on the following Monday. If any of the listed holidays falls on a Saturday, the preceding Friday shall be a regular work day.
- S. Paid Holidays: New Year's Day, Memorial Day, Independence Day, Labor Day, Thanksgiving Day, Friday after Thanksgiving Day, Christmas Day, the Day after Christmas, and A Floating Holiday (9). If any of the listed holidays falls on a Sunday, the day observed by the Nation shall be considered a holiday and compensated accordingly.
- V. Holidays: New Year's Day, President's Birthday, Memorial Day, Independence Day, Labor Day, Thanksgiving Day, the Friday after Thanksgiving Day, Christmas Day, the day before or after Christmas, and the day before or after New Year's Day. If any of the above listed holidays falls on a Sunday, the day observed by the Nation shall be considered a holiday and compensated accordingly.
- W. Holidays: New Year's Day, Day After New Year's, Memorial Day, Independence Day, Labor Day, Thanksgiving Day, the Friday after Thanksgiving Day, Christmas Eve Day, Christmas Day, the day after Christmas, the day before New Year's Day, and a Floating Holiday.
- X. Holidays: New Year's Day, Day before or after New Year's Day, Presidents' Day, Memorial Day, Independence Day, Labor Day, Thanksgiving Day, the Friday after Thanksgiving Day, Christmas Day, and the day before or after Christmas day. If a holiday falls on a Saturday or on a Friday that is the normal day off, then the holiday will be taken on the last normal workday. If the holiday falls on a Monday that is the normal day off or on a Sunday, then the holiday will be taken on the next normal workday.
- Y. Holidays: New Year's Day, Presidents' Day, Memorial Day, Independence Day, Labor Day, Thanksgiving Day, the Friday after Thanksgiving Day, and Christmas Day. (8) If the holiday falls on a Sunday, then the day observed by the federal government shall be considered a holiday and compensated accordingly.
- Z. Holidays: New Year's Day, Memorial Day, Independence Day, Labor Day, Thanksgiving Day, the Friday and Saturday after Thanksgiving Day, Christmas Eve, and Christmas Day (9). Any holiday which falls on a Saturday shall be observed as a holiday on the preceding Friday. Any holiday which falls on a Sunday shall be observed as a holiday on the following Monday.

Holiday Codes Continued

15. G. New Year's Day, Washington's Birthday, Memorial Day, Independence Day, Labor Day, Thanksgiving Day, The Friday After Thanksgiving Day, the last scheduled workday before Christmas, and Christmas Day (9). If any of the listed holidays falls on a Sunday, the day observed by the Nation shall be considered a holiday and compensated accordingly.
- H. Holidays: New Year's Day, Martin Luther King Jr. Day, Independence Day, Memorial Day, Labor Day, Thanksgiving Day, the Friday after Thanksgiving Day, the Last Working Day before Christmas Day and Christmas Day (9). Any holiday which falls on a Sunday shall be observed as a holiday on the following Monday. Any holiday which falls on a Saturday shall be observed as a holiday on the preceding Friday.
- I. Holidays: New Year's Day, President's Day, Independence Day, Memorial Day, Labor Day, Thanksgiving Day, The Friday After Thanksgiving Day, The Day Before Christmas Day And Christmas Day (9). Any holiday which falls on a Sunday shall be observed as a holiday on the following Monday. Any holiday which falls on a Saturday shall be observed as a holiday on the preceding Friday.
- J. Holidays: New Year's Day, Martin Luther King Jr. Day, Memorial Day, Independence Day, Labor Day, Thanksgiving Day, the Friday and Saturday after Thanksgiving Day, and Christmas Day (9). Any holiday which falls on a Sunday shall be observed as a holiday on the following Monday. If any of the listed holidays falls on a Saturday, the preceding Friday shall be a regular work day.
- K. Holidays: New Year's Day, Memorial Day, Independence Day, Thanksgiving Day, the Friday and Saturday after Thanksgiving Day, And Christmas Day (8). Any holiday which falls on a Sunday shall be observed as a holiday on the following Monday. Any holiday which falls on a Saturday shall be observed as a holiday on the preceding Friday.
- L. Holidays: New Year's Day, Memorial Day, Independence Day, Labor Day, Veteran's Day, Thanksgiving Day, the Friday after Thanksgiving Day, and Christmas Day (8). Any holiday which falls on a Sunday shall be observed as a holiday on the following Monday. If any of the listed holidays falls on a Saturday, the preceding Friday shall be a regular work day.
- M. Holidays: New Year's Day, Martin Luther King Jr. Day, Independence Day, Memorial Day, Labor Day, Thanksgiving Day, the Friday after Thanksgiving Day, Christmas Eve Day and Christmas Day (9). Any holiday which falls on a Sunday shall be observed as a holiday on the following Monday. If any of the listed holidays falls on a Saturday, the preceding Friday shall be a regular work day.
- N. Holidays: New Year's Day, Memorial Day, Independence Day, Labor Day, Veteran's Day, Thanksgiving Day, the Friday after Thanksgiving Day, and Christmas Day (8). Any holiday which falls on a Sunday shall be observed as a holiday on the following Monday.

Note Codes

8. D. Workers working with supplied air on hazmat projects receive an additional \$1.00 per hour.
- L. Workers on hazmat projects receive additional hourly premiums as follows -Level A: \$0.75, Level B: \$0.50, And Level C: \$0.25.
- M. Workers on hazmat projects receive additional hourly premiums as follows: Levels A & B: \$1.00, Levels C & D: \$0.50.
- N. Workers on hazmat projects receive additional hourly premiums as follows -Level A: \$1.00, Level B: \$0.75, Level C: \$0.50, And Level D: \$0.25.

Note Codes Continued

8. S. Effective August 31, 2012 – A Traffic Control Supervisor shall be present on the project whenever flagging or spotting or other traffic control labor is being utilized. Flaggers and Spotters shall be posted where shown on approved Traffic Control Plans or where directed by the Engineer. All flaggers and spotters shall possess a current flagging card issued by the State of Washington, Oregon, Montana, or Idaho. This classification is only effective on or after August 31, 2012.
- T. Effective August 31, 2012 – A Traffic Control Laborer performs the setup, maintenance and removal of all temporary traffic control devices and construction signs necessary to control vehicular, bicycle, and pedestrian traffic during construction operations. Flaggers and Spotters shall be posted where shown on approved Traffic Control Plans or where directed by the Engineer. All flaggers and spotters shall possess a current flagging card issued by the State of Washington, Oregon, Montana, or Idaho. This classification is only effective on or after August 31, 2012.
- U. Workers on hazmat projects receive additional hourly premiums as follows – Class A Suit: \$2.00, Class B Suit: \$1.50, And Class C Suit: \$1.00. Workers performing underground work receive an additional \$0.40 per hour for any and all work performed underground, including operating, servicing and repairing of equipment. The premium for underground work shall be paid for the entire shift worked. Workers who work suspended by a rope or cable receive an additional \$0.50 per hour. The premium for work suspended shall be paid for the entire shift worked. Workers who do “pioneer” work (break open a cut, build road, etc.) more than one hundred fifty (150) feet above grade elevation receive an additional \$0.50 per hour.
- V. In addition to the hourly wage and fringe benefits, the following depth and enclosure premiums shall be paid. The premiums are to be calculated for the maximum depth and distance into an enclosure that a diver reaches in a day. The premiums are to be paid one time for the day and are not used in calculating overtime pay.
- Depth premiums apply to depths of fifty feet or more. Over 50' to 100' - \$2.00 per foot for each foot over 50 feet. Over 101' to 150' - \$3.00 per foot for each foot over 101 feet. Over 151' to 220' - \$4.00 per foot for each foot over 220 feet. Over 221' - \$5.00 per foot for each foot over 221 feet.
- Enclosure premiums apply when divers enter enclosures (such as pipes or tunnels) where there is no vertical ascent and is measured by the distance travelled from the entrance. 25' to 300' - \$1.00 per foot from entrance. 300' to 600' - \$1.50 per foot beginning at 300'. Over 600' - \$2.00 per foot beginning at 600'.
- W. Meter Installers work on single phase 120/240V self-contained residential meters. The Lineman/Groundmen rates would apply to meters not fitting this description.
- X. Workers on hazmat projects receive additional hourly premiums as follows - Class A Suit: \$2.00, Class B Suit: \$1.50, Class C Suit: \$1.00, and Class D Suit: \$0.50. Special Shift Premium: Basic hourly rate plus \$2.00 per hour.
- When due to conditions beyond the control of the Employer or when an owner (not acting as the contractor), a government agency or the contract specifications requires that work can only be performed outside the normal 5 am to 6pm shift, then the special shift premium will be applied to the basic hourly rate. When an employee works on a special shift, they shall be paid a special shift premium for each hour worked unless they are in OT or Double-time status. (For example, the special shift premium does not waive the overtime requirements for work performed on Saturday or Sunday.)
- Y. Tide Work: When employees are called out between the hours of 6:00 p.m. and 6:00 a.m. to work on tide work (work located in the tide plane) all time worked shall be at one and one-half times the hourly rate of pay.
- Swinging Stage/Boatswains Chair: Employees working on a swinging state or boatswains chair or under conditions that require them to be tied off to allow their hands to be free shall receive seventy-five cents (\$0.75) per hour above the classification rate.

Note Codes Continued

8. Z. Workers working with supplied air on hazmat projects receive an additional \$1.00 per hour.

Special Shift Premium: Basic hourly rate plus \$2.00 per hour. When due to conditions beyond the control of the Employer or when an owner (not acting as a contractor), a government agency or the contract specifications require that more than (4) hours of a special shift can only be performed outside the normal 6 am to 6pm shift, then the special shift premium will be applied to the basic straight time for the entire shift. When an employee works on a special shift, they will be paid a special shift premium for each hour worked unless they are in overtime or double-time status. (For example, the special shift premium does not waive the overtime requirements for work performed on Saturday or Sunday.)

9. A. Workers working with supplied air on hazmat projects receive an additional \$1.00 per hour.

Special Shift Premium: Basic hourly rate plus \$2.00 per hour. When due to conditions beyond the control of the Employer or when an owner (not acting as the contractor), a government agency or the contract specifications require that more than four (4) hours of a special shift can only be performed outside the normal 6 am to 6pm shift, then the special shift premium will be applied to the basic straight time for the entire shift. When an employee works on a special shift, they shall be paid a special shift premium for each hour worked unless they are in overtime or double-time status. (For example, the special shift premium does not waive the overtime requirements for work performed on Saturday or Sunday.)

Certified Crane Operator Premium: Crane operators requiring certifications shall be paid \$0.50 per hour above their classification rate.

Boom Pay Premium: All cranes including tower shall be paid as follows based on boom length:

(A) – 130' to 199' – \$0.50 per hour over their classification rate.

(B) – 200' to 299' – \$0.80 per hour over their classification rate.

(C) – 300' and over – \$1.00 per hour over their classification rate.

- B. The highest pressure registered on the gauge for an accumulated time of more than fifteen (15) minutes during the shift shall be used in determining the scale paid.

Tide Work: When employees are called out between the hours of 6:00 p.m. and 6:00 a.m. to work on tide work (work located in the tide plane) all time worked shall be at one and one-half times the hourly rate of pay. Swinging Stage/Boatswains Chair: Employees working on a swinging stage or boatswains chair or under conditions that require them to be tied off to allow their hands to be free shall receive seventy-five cents (\$0.75) per hour above the classification rate.

- C. Tide Work: When employees are called out between the hours of 6:00 p.m. and 6:00 a.m. to work on tide work (work located in the tide plane) all time worked shall be at one and one-half times the hourly rate of pay. Swinging Stage/Boatswains Chair: Employees working on a swinging stage or boatswains chair or under conditions that require them to be tied off to allow their hands to be free shall receive seventy-five cents (\$0.75) per hour above the classification rate.

Effective August 31, 2012 – A Traffic Control Supervisor shall be present on the project whenever flagging or spotting or other traffic control labor is being utilized. A Traffic Control Laborer performs the setup, maintenance and removal of all temporary traffic control devices and construction signs necessary to control vehicular, bicycle, and pedestrian traffic during construction operations. Flaggers and Spotters shall be posted where shown on approved Traffic Control Plans or where directed by the Engineer. All flaggers and spotters shall possess a current flagging card issued by the State of Washington, Oregon, Montana, or Idaho. These classifications are only effective on or after August 31, 2012.

- D. Industrial Painter wages are required for painting within industrial facilities such as treatment plants, pipelines, towers, dams, bridges, power generation facilities and manufacturing facilities such as chemical plants, etc., or anywhere abrasive blasting is necessary to prepare surfaces, or hazardous materials encapsulation is required.

Note Codes Continued

9. E. Heavy Construction includes construction, repair, alteration or additions to the production, fabrication or manufacturing portions of industrial or manufacturing plants, hydroelectric or nuclear power plants and atomic reactor construction. Workers on hazmat projects receive additional hourly premiums as follows -Level A: \$1.00, Level B: \$0.75, Level C: \$0.50, And Level D: \$0.25.
- F. Industrial Painter wages are required for painting within industrial facilities such as treatment plants, pipelines, towers, dams, power generation facilities and manufacturing facilities such as chemical plants, etc., or anywhere abrasive blasting is necessary to prepare surfaces, or hazardous materials encapsulation is required.
- H. One (1) person crew shall consist of a Party Chief. (Total Station or similar one (1) person survey system). Two (2) person survey party shall consist of a least a Party Chief and a Chain Person. Three (3) person survey party shall consist of at least a Party Chief, an Instrument Person, and a Chain Person.