

TABLE OF CONTENTS

	<u>PAGE</u>
NOTICE TO CONTRACTORS.....	3
INSTRUCTIONS TO BIDDERS & CHECKLISTS	4
QUOTE.....	6
SUBCONTRACTOR LIST	10
CONTRACTOR WAGE LAW COMPLIANCE CERTIFICATION	11
SMALL PUBLIC WORKS CONTRACT	12
CERTIFICATE OF INSURANCE	22
PERFORMANCE AND PAYMENT BOND	23
CONTRACTOR’S RETAINAGE OPTION	25
RETAINAGE BOND TO CITY OF FEDERAL WAY	26
PREVAILING WAGES AND BENEFIT CODE KEY.....	
SPECIAL PROVISIONS	
STANDARD PLANS AND DETAILS.....	

NOTICE TO CONTRACTORS

ON-CALL SIDEWALK AND CURB REPLACEMENT

The City of Federal Way extends this invitation to bid to selected contractors listed with the MRSC Small Works Roster. This project is a small public works project and will be awarded under the small works roster process.

PURPOSE: The City of Federal Way (“City”) is requesting quotes for **On-Call Sidewalk and Curb Replacement**. Quotes will be received via email only to PW_Bids@cityoffederalway.com on September 15, 2023 at 2:00 PM. Quotes received after that time and date will not be considered.

This project shall consist of: On-call sidewalk and curb removal and replacement services (“Services”) in various locations as requested by the City. Upon identification of a project by the City, the City and Contractor will negotiate scope, schedule, and budget for the specific project which will be included in a “Task Order.” Prices will be based on unit bid prices. The “Task Order” form is attached to the Small Public Works contract as “Exhibit A.” The City is not obligated to assign any specific number of tasks to the Contractor and the City and Contractor’s obligations hereunder are limited to the tasks assigned in written “Task Orders.” Estimated dollars spent on these services range from \$20,000 to \$100,000 per year.

The City anticipates awarding this project to the successful bidder and intends to give Notice to Proceed as soon as the Contract and all required documents are executed in full.

BID DOCUMENTS: Plans, Specifications, and Addenda can be found at <https://www.cityoffederalway.com/bids/on-call-sidewalk-and-curb-replacement>

QUESTIONS: Any questions must be directed to Desiree Winkler, P.E., Deputy Public Works Director, by email at desiree.winkler@cityoffederalway.com

OTHER PROVISIONS: All quotes and this Project shall be governed by the Contract, as defined by the Washington State Department of Transportation Standard Specifications for Road, Bridge, and Municipal Construction 2023 (Standard Specifications), which is incorporated by this reference as though set forth in full.

All quotes shall be in accordance with the Contract.

The recipient, in accordance with Title VI of the Civil Rights Act of 1964, (78 Stat. 252, 42 U.S.C. 2000d to 2000d-4) and the Regulations, hereby notifies all bidders that it will affirmatively ensure that in any contract entered into pursuant to this advertisement, disadvantaged business enterprises will be afforded full and fair opportunity to submit bids in response to this invitation and will not be discriminated against on the grounds of race, color or national origin in consideration for an award. The City encourages minority and women-owned firms to submit bids consistent with the City’s policy to ensure that such firms are afforded the maximum practicable opportunity to compete for and obtain public contracts.

The City of Federal Way reserves the right to reject any and all quotes, waive any informalities or minor irregularities in the solicitation process, and determine which quote or bidder meets the criteria set forth in the bid documents.

INSTRUCTIONS TO BIDDERS & CHECKLISTS

(1) NOTICE TO CONTRACTORS AND CONTRACT DOCUMENTS

Contractors must comply with the bidder instructions in the Notice to Contractors and the Contract Documents.

(2) EXAMINATION OF QUOTE AND CONTRACT DOCUMENTS – BIDDER RESPONSIBILITIES

The submission of a quote shall constitute an acknowledgment upon which the City may rely that the bidder has thoroughly examined and is familiar with the bid and Small Public Works Contract and the other Contract Documents, the Project site, the availability of materials and labor, publically available information, and has reviewed and inspected all applicable federal, state, and local statutes, regulations, ordinances and resolutions dealing with or related to the equipment and/or services to be provided herein. The failure or neglect of a bidder to examine such documents, statutes, regulations, ordinances or resolutions shall in no way relieve the bidder from any obligations with respect to the bidder's quote or the contract documents. No claim for additional compensation will be allowed which is based upon a lack of knowledge of any contract documents, statutes, regulations, ordinances or resolutions. Bidders shall visit delivery and service locations(s) as required. Bidders shall become familiar with and verify any environmental factors, which may impact current or future prices for this requirement.

(3) INTERPRETATION OF QUOTE AND CONTRACT DOCUMENTS

No oral clarifications, interpretations, or representation will be made to any bidder as to the meaning of the quote or Contract Documents. Bidders shall not rely upon any oral statement or conversation they may have with City's employees, agents, representatives, consultants, or design professionals regarding the Contract Documents, whether at the pre-bid meeting or otherwise and no oral communications will be binding upon the City. Any questions must be directed to Desireé Winkler, P.E., Deputy Public Works Director, by email at desiree.winkler@cityoffederalway.com Any interpretation deemed necessary by the City will be in the form of an Addendum to the bid documents and when issued will be sent as promptly as is practical to all parties to whom the bid documents have been issued. All such Addenda shall become part of the bid.

(4) QUOTE PRICE

The quote price shall include everything necessary for the completion of the Contract and the Work including, but not limited to, furnishing all materials, equipment, tools, freight charges, facilities and all management, superintendence, labor and service, except as may be provided otherwise in the Contract Documents. All Washington State sales tax and all other government taxes, assessments and charges shall be included in the various Bid item prices as required by law. The offer shall remain in effect ninety (90) days after the bid opening.

(5) POSTPONEMENT OF QUOTE OPENING

The City reserves the right to postpone the date and time for receiving the quotes by Addendum at any time prior to the bid opening date and time announced in these documents.

(6) REJECTION OF BIDS

The City reserves the right to reject any quote for any reason including, but not limited to, the reasons listed in Special Provisions Section 1-02.13. The City further reserves the right to reject any portion of any quotes and/or to reject all quotes. In consideration for the City's review and evaluation of its quote, the bidder waives and releases any claims against the City arising from any rejection of any or all quotes. If, in the opinion of the City, there is reason to believe that collusion exists among bidders, none of the bids of the participants in such collusion will be considered.

(7) RECYCLED PRODUCTS

The Contractor shall use recycled paper for proposals and for any printed or photocopied material created pursuant to a contract with the City whenever practicable and use both sides of paper sheets for reports submitted to the City whenever practicable.

(8) BIDDER'S CHECKLIST

The bidder's attention is especially called to the following forms, which must be executed in full as required. Failure to comply may result in rejection of any bid not so complying.

- Quote:** The Quote shall be completed and fully executed, including filling in the total bid amount.
- Subcontractor List:** The Subcontractor List shall be filled in by the bidder.
- Contractor Certification – Wage Law Compliance:** This form shall be filled in and fully executed by the bidder.
-

(9) CONTRACT CHECKLIST

The following documents are to be executed and delivered to the City after the Bid is awarded:

- Small Public Works Contract:** The successful bidder will fully execute and deliver to the City the Small Public Works Contract ("Contract") from these Bid Documents.
- Certificate of Insurance:** The successful bidder will provide a Certificate of Insurance evidencing the insurance requirement set forth in the Contract.
- Performance/Payment Bond:** The successful bidder will provide a fully executed Performance/Payment Bond as appropriate or in lieu of a bond, option to authorize the City to retain ten percent (10%).
- Contractor's Retainage Option:** The successful bidder will fully execute and deliver to the City the Contractor's Retainage Option.
- Contractor's Retainage Bond:** If the retainage bond option is chosen, then the successful bidder will fully execute and deliver to the City the Contractor's Retainage Bond.
- Business License:** The successful bidder will provide a copy of a current Business License with the City of Federal Way.

QUOTE
On-Call Sidewalk and Curb Replacement

QUOTE SUBMITTED VIA EMAIL TO:

PW_Bids@cityoffederalway.com Subject line "Bid Submittal - On-Call Sidewalk and Curb Replacement"

QUOTE SUBMITTED BY:

Bidder: _____
Full Legal Name of Firm

Contact: _____
Individual with Legal Authority to sign Bid and Contract

Address: _____
Street Address

City, State Zip

Phone: _____

E-Mail: _____

- Select One of the Following:
- Corporation
 - Partnership.
 - Individual
 - Other

State Contractor's License No.: _____

State Contractor's License Expiration Date: _____ / _____ / _____
Month Day Year

State UBI No.: _____

State Worker's Comp. Account No.: _____

NOTE: All entries shall be written in ink or typed. Unit prices for all items, all extensions, and total amount of bid shall be shown. Enter unit prices in numerical figures only, in dollars and cents to two (2) decimal places (including for whole dollar amounts). All figures must be clearly legible. Bids with illegible figures in the unit price column will be regarded as nonresponsive. Where conflict occurs between the unit price and the total amount specified for any item, the unit price shall prevail, and totals shall be corrected to conform thereto. The Bidder shall complete this entire Bid Form or this bid may be considered non-responsive. The City may correct obvious mathematical errors. The City of Federal Way reserves the right to reject any and all bids, waive any informalities or minor irregularities in the bidding, and determine which bid or bidder meets the criteria set forth in the bid documents.

In order to provide a basis of evaluation for each bidder, please provide prices for each of the items below. Costs shall include all materials, labor, tools, and equipment needed for a complete installation. All taxes shall be included in the unit price following WA State Sales Tax: WAC 458-20-171 – Use Tax (Rule 171).

#	Description	Qty	Units	Unit Price	Total
1	Mobilization*	1	LS	N/A	N/A
2	Traffic Control Supervisor	4	HR		
3	Other Traffic Control Labor	10	HR		
4	Flaggers	10	HR		
5	Traffic Control Devices	1	FA	\$500.00	\$500.00
6	Sawcutting	30	LF		
7	Remove Curb and Gutter	15	LF		
8	Remove Extruded Curb	30	LF		
9	Remove Concrete Sidewalk	8	SY		
10	Remove HMA	1	CY		
11	Crushed Surfacing Top Course	3	TON		
12	Commercial HMA	2	TON		
13	Cement Conc. Traffic Curb and Gutter	15	LF		
14	Extruded Curb	30	LF		
15	Cement Concrete Curb Ramp Type Perpendicular	1	EA		
16	Cement Concrete Curb Ramp Type Parallel	1	EA		
17	Detectable Warning Surface	20	SF		
18	Cement Conc. Sidewalk	8	SY		
TOTAL					

*Mobilization equal to 10% of the negotiated costs will be added to each project location

The documents incorporated by reference, as if fully set forth, are the Notice to Contractors, the Instructions to Bidders and Checklists, the Contractor’s Quote (including all forms and supplemental information listed on the Bidders Checklist), the Contract Documents (including Project Plans, Specifications, and all Appendices, Amendments, and Supplemental Reports & Information), the Contract Provisions (including all forms and supplemental information listed on the Contract Checklist), the version of the Washington State Standard Specifications for Road, Bridge, and Municipal Construction identified herein, and any other documents provided to bidders and/or referenced in or referred to by the Contract Documents.

Pursuant to and in compliance with the Notice to Contractors for the Project, and other documents relating thereto, the undersigned has carefully examined all of the bid and contract documents, considered conditions which may affect the delivery, supply and maintenance for the Project, and hereby proposes to furnish all labor, materials and perform all work as required in strict accordance with the contract documents, for the referenced bid amount, inclusive of Washington State sales tax and all other government taxes, assessments and charges as required by law.

NON-COLLUSION AFFIDAVIT

By signing this quote, the undersigned acknowledges that the person(s), firm, association, or corporation has (have) not, either directly or indirectly, entered into any agreement, participated in any collusion, or otherwise taken any action in restraint of free competitive bidding in connection with this project.

To report rigging activities, call 1-800-424-9071. The U.S. Department of Transportation (USDOT) operates the toll-free hotline Monday through Friday, 8:00 a.m. to 5:00 p.m., Eastern Time. Anyone with knowledge of possible bid rigging, bidder collusion, or other fraudulent activities should use the hotline to report such activities. The hotline is part of USDOT’s continuing effort to identify and investigate highway construction contract fraud and abuse and is operated under the direction of the USDOT Inspector General. All information will be treated confidentially and caller anonymity will be respected.

CONFLICTS OF INTEREST, GRATUITIES, & NON-COMPETITIVE PRACTICES

By signing this quote, the undersigned agrees as follows:

- (1) That it has no direct or indirect pecuniary or proprietary interest, that it shall not acquire any interest which conflicts in any manner or degree with the work, services, equipment or materials required to be performed and/or provided under this contract and that it shall not employ any person or agent having any such interests. In the event that the Contractor or its agents, employees or representatives hereafter acquires such a conflict of interest, it shall immediately disclose such interest to the City and take action immediately to eliminate the conflict or to withdraw from this contract, as the City may require; and
- (2) That no person or selling agency except bona fide employees or designated agents or representatives of the Contractor have been employed or retained to solicit or secure this contract with an agreement or understanding that a commission, percentage, brokerage, or contingent fee would be paid; and
- (3) That no gratuities in the form of entertainment, gifts or otherwise, were offered or given by the Contractor or any of its agents, employees or representatives, to any official, member or employee of the City or other governmental agency with a view toward securing this contract or securing favorable treatment with respect to the awarding or amending, or the making of any determination with respect to the performance of this contract.

AFFIDAVIT OF ELIGIBILITY

The Contractor certifies that it is properly licensed and registered under the laws of the State of Washington and has not been determined to have been in violation of RCW 50.12.070(1)(b), RCW 51.16.070(1)(b), or RCW 82.32.070(2) within the last two years. The Contractor further certifies that it has not been determined, within the last one year, to have committed any combination of two of the following violations or infractions within a five year period: (1) Violated RCW 51.48.020(1) or 51.48.103; or (2) Committed an infraction or violation under Chapter 18.27 RCW.

CERTIFICATION OF LAWFUL EMPLOYMENT

The Contractor hereby certifies that it has complied with all provisions of the Immigration and Nationality Act now or as herein after amended, 8 U.S.C. 1101 et. Seq., and that all employees, including subcontractor employees, are lawfully permitted to perform work in the United States as provided in this agreement with the City of Federal Way.

Receipt of the following Addendums is hereby acknowledged:

Addendum No. _____ Date Issued: _____

Addendum No. ____

Date Issued: _____

Addendum No. ____

Date Issued: _____

The undersigned individual represents and warrants that he or she is dully authorized to execute the bid and all bid documents on behalf of any partnership, joint venture or corporation.

By: _____

Signature

Printed Name

Title

SUBCONTRACTOR LIST

Local Agency Name CITY OF FEDERAL WAY
Local Agency Address 33325 8TH AVE S FEDERAL WAY, WA 98003

Local Agency Subcontractor List

Prepared in compliance with RCW 39.30.060 as amended

To Be Submitted with the Bid Proposal

Project Name _____

Failure to list subcontractors with whom the bidder, if awarded the contract, will directly subcontract for performance of the work of heating, ventilation and air conditioning, plumbing, as described in Chapter 18.106 RCW, and electrical, as described in Chapter 19.28 RCW or naming more than one subcontractor to perform the same work will result in your bid being non-responsive and therefore void.

Subcontractor(s) with whom the bidder will directly subcontract that are proposed to perform the work of heating, ventilation and air conditioning, plumbing, as described in Chapter 18.106 RCW, and electrical as described in Chapter 19.28 RCW must be listed below. The work to be performed is to be listed below the subcontractor(s) name.

To the extent the Project includes one or more categories of work referenced in RCW 39.30.060, and no subcontractor is listed below to perform such work, the bidder certifies that the work will either (i) be performed by the bidder itself, or (ii) be performed by a lower tier subcontractor who will not contract directly with the bidder.

Subcontractor Name _____
Work to be Performed _____

Subcontractor Name _____
Work to be Performed _____

Subcontractor Name _____
Work to be Performed _____

Subcontractor Name _____
Work to be Performed _____

Subcontractor Name _____
Work to be Performed _____

* Bidder's are notified that is the opinion of the enforcement agency that PVC or metal conduit, junction boxes, etc, are considered electrical equipment and therefore considered part of electrical work, even if the installation is for future use and no wiring or electrical current is connected during the project.

SR

DOT Form 271-015A EF
Revised 08/2012

CONTRACTOR WAGE LAW COMPLIANCE CERTIFICATION

FAILURE TO RETURN THIS CERTIFICATION AS PART OF THE BID QUOTE PACKAGE WILL MAKE THIS BID NONRESPONSIVE AND INELIGIBLE FOR AWARD.

I hereby certify, under penalty of perjury under the laws of the State of Washington, on behalf of the firm identified below that, to the best of my knowledge and belief, this firm has **NOT** been determined by a final and binding citation and notice of assessment issued by the Washington State Department of Labor and Industries or through a civil judgment entered by a court of limited or general jurisdiction to have willfully violated, as defined in RCW 49.48.082, any provision of Chapters 49.46, 49.48, and 49.52 RCW within three (3) years prior to the date of the Request for Bids.

Bidder Name: _____
Print Full Legal Name of Firm

By: _____
Signature of Authorized Person

Print Name of Person Making Certifications for Firm

Title: _____
Title of Person Signing Certificate

Place: _____
Print City and State Where Signed

Date: _____

SMALL PUBLIC WORKS CONTRACT

THIS SMALL PUBLIC WORKS CONTRACT ("Contract") is dated effective this ____ day of _____, 20__ and is made by and between the City of Federal Way, a Washington municipal corporation ("City or Owner"), and _____, a _____ ("Contractor"), for the project known as "On-Call Sidewalk and Curb Replacement" (the "Project").

A. The City desires to retain an independent contractor to furnish all labor and materials necessary to perform work necessary to complete the Project; and

B. The Contractor has the requisite skill and experience to perform such work.

NOW, THEREFORE, the parties ("Parties") agree to the following terms and conditions:

1. SERVICES BY CONTRACTOR

Contractor shall perform all Work and furnish all tools, materials, supplies, equipment, labor and other items incidental thereto necessary for the construction and completion of the Project. Contractor shall perform the Work in a manner consistent with accepted practices for other properly licensed contractors and in accordance with and as described in the Contract Documents, which Work shall be completed to the City's satisfaction, within the time period prescribed by the City and pursuant to the direction of the Mayor or his or her designee.

2. TERM

2.1 This Contract shall commence on the effective date of this Contract and continue until December 31, 2026 unless mutually extended through contract change order. This on-call contract may be extended a maximum of one, 1-year extension.

2.2 The Contractor must complete the Work in accordance with the number of Working Days for the Project as identified in the Contract Documents. With regard to obtaining Substantial Completion and the Completion Date by the Contractor, time is of the essence. In the event the Work is not substantially completed within the time specified in the Contract Documents, Contractor agrees to pay to the City liquidated damages in the amount set forth in the Contract Documents. The parties acknowledge that delays inconvenience the public and cost taxpayers undue sums of money, adding time needed for administration, inspection, and supervision of the Project and diverting City resources from other projects and obligations.

2.3 If the Contractor is unreasonably delayed by others, notification shall be made in writing to the Engineer in accordance with the Contract Documents. Any request for a time extension or additional compensation (including expectancy or consequential damages) allegedly resulting from such delay shall be made in accordance with the procedures of the Contract Documents. Failure to follow the notice procedures in the Contract Documents is a full and complete waiver of Contractor's right to additional time, money, damages, or other relief (including expectancy or consequential damages) as a result of the event or condition giving rise to such request.

3. COMPENSATION

3.1 In consideration of the Contractor performing the Work, the City agrees to pay the Contractor an amount not to exceed _____ and ____/100 Dollars (\$ _____), which amount shall constitute full and complete payment by the City ("Total Compensation"). The Contractor shall be solely responsible for the payment of any taxes imposed by any lawful jurisdiction as a result of the performance and payment of this Contract.

3.2 The City shall pay the Contractor for Work performed under this Contract as detailed in the Task Orders issued for each scope of work specified in each associated Task Order and consistent with the unit prices specified in the Bid Quote and as detailed in the Contract Documents. The Bid Quote is incorporated herein and made a part hereof by this reference. The City shall have the right to withhold payment to the Contractor for any of the Work not completed in a satisfactory manner, in the City's sole and absolute discretion, which shall be withheld until such time as Contractor modifies or repairs the Work so that the Work is acceptable to the City.

Payment to the Contractor for partial estimates, final estimates, and retained percentages shall be subject to controlling laws. Annual increases in the Bid Quote prices (starting January 2025) may be negotiated and executed via change order to accommodate material cost increases, union labor contract increases, and use of subcontractors in-lieu of in-house staff. Contract increases shall be no more than the Puget Sound Cost Price Index on June 30 for the previous year. Contractor shall provide all back-up documentation to support annual cost increases.

3.3 In addition to the requirements set forth in the Contract Documents, the Contractor shall maintain Project cost records by cost codes and shall contemporaneously segregate and separately record, at the time incurred, all costs (1) directly associated with each work activity, (2) directly or indirectly resulting from any event, occurrence, condition, or direction for which Contractor seeks an adjustment in Contract price Contract time, or related to any other Claim or protest. Any work performed for which Contractor intends to seek an adjustment in Contract Price or Contract Time, or related to any other Claim or protest, shall be recorded on the same day the work is performed and kept separate so as to distinguish it from Contract Work.

4. INDEPENDENT CONTRACTOR

4.1 It is the intention and understanding of the Parties that the Contractor shall be an independent contractor and that the City shall be neither liable nor obligated to pay Contractor sick leave, vacation pay or any other benefit of employment, nor to pay any social security or other tax which may arise as an incident of employment. The Contractor shall not conduct itself as nor claim to be an officer or employee of the City. The Contractor shall pay all income and other taxes due. Industrial or any other insurance that is purchased for the benefit of the City, regardless of whether such may provide a secondary or incidental benefit to the Contractor, shall not be deemed to convert this Agreement to an employment contract. It is recognized that Contractor may or will be performing professional services during the Term for other parties; provided, however, that such performance of other services shall not conflict with or interfere with Contractor's ability to perform the Services. Contractor agrees to resolve any such conflicts of interest in favor of the City. Nothing contained in this Contract shall create a contractual or direct relationship with or a cause of action in favor of a Subcontractor or third party against the City, or by the Contractor against the Engineer, or against any of their agents, employees, engineers, or consultants.

4.2 If the Contractor is a sole proprietorship or if this is a contract with an individual, the contractor agrees to notify the City and complete any required form if the Contractor retired under a State of Washington retirement system and agrees to indemnify any losses the City may sustain through the Contractor's failure to do so.

5. INDEMNIFICATION

5.1 Contractor Indemnification.

5.1.1 The Contractor shall indemnify, defend, and hold the City, its elected officials, officers, employees, agents, consultants, and volunteers (collectively "the Indemnified Parties") harmless from any costs or losses, and pay and damages or judgments, related to any claim brought by any person employed in any capacity by the Contractor or subcontractor or supplier (of any tier) performing the Work, with respect to the payment of wages, salaries, or other compensation or benefits including but not limited to benefits such as medical, health, retirement, vacation, sick leave, etc.

5.1.2. To the fullest extent permitted by law, the Contractor shall defend, release, indemnify, and hold harmless the City and the Indemnified Parties for, from, and against any and all claims, demands, losses, costs, damages, suits, actions, expenses, fines, penalties, response costs, and liabilities (including costs and all attorney and expert fees and internal personnel costs of investigation) of whatsoever kind or nature to the extent arising from, resulting from, connected with, or incident to the Contractor's performance or failure to perform this Contract or the Work or its breach of this Contract; provided, however, that if the provisions of RCW 4.24.155 apply to the Work and any injuries to persons or property arising out of the performance of this Contract are caused by or result from the concurrent negligence of the Contractor or its subcontractors, agents, employees, or anyone for whom they are legally liable, and an Indemnified Party, the indemnification and defense obligations under this Section 5.1.2 apply only to the extent of the negligence of the Contractor, its subcontractors, agents, employees, and anyone for whom they are legally liable.

5.1.3 Contractor specifically assumes potential liability for actions brought by the Contractor's own employees or former employees against any Indemnified Party, and for that purpose Contractor waives any immunity that may be granted to it under the Washington State Industrial Insurance Act, Title 51 RCW. Contractor's indemnification shall not be limited in any way by any limitation on the amount of damages, compensation or benefits payable to or by any third party under workers' compensation acts, disability benefit acts or any other benefits acts or programs. Provided, however, the Contractor's waiver of immunity by the provisions of this paragraph extends only to claims against the Contractor by any Indemnified party, and does not include, or extend to, any claims by the Contractor's employee directly against the Contractor. The Contractor recognizes that this waiver was specifically entered into.

5.2 Contractor Release. Any deviation, alteration, variation, addition, or omission in the Work by Contractor from the Contract Documents shall preclude Contractor from bringing any Claim or request for additional time or compensation on the basis of an alleged defect or error in the Contract Documents related to or arising, in any way, from that deviation, alteration, variation, addition, or omission. The Contractor further warrants that any alteration, variation, deletion, or omission fully complies with or exceeds all requirements of the Contract Documents and assumes all risk thereof.

5.3 Survival. The provisions of this Section shall (1) survive the expiration or termination of this Contract with respect to any event occurring prior to such expiration or termination, final payment hereunder, and any applicable statute of repose with respect to claims, fines, costs or damages brought or made against any Indemnified Party; (2) shall not be limited by RCW 4.16326(g); and (3) are in addition to any other rights or remedies which the City and/or any of the Indemnified Parties may have by law or under this Contract.

5.4 Offset. In the event of any claim or demand made against any Indemnified Party hereunder, the City may, in its sole discretion, reserve, retain or apply any monies due to the Contractor under the Contract or any other agreement or contract with the City for the purpose of resolving such claims; provided, however, that the City may, in the City's sole discretion, release such funds if the Contractor provides the City with adequate assurance of the protection of the City's and the other Indemnified Parties interests.

5.5 The Contractor shall ensure that each Subcontract includes a provision requiring each Subcontractor to indemnify and defend the City and the Indemnified Parties in the same manner, to the same extent, and for the same duration as Contractor agrees to indemnify and defend the City and the Indemnified Parties in this Section 5.

6. OWNERSHIP OF DOCUMENTS

All originals and copies of work product, including plans, sketches, layouts, designs, design specifications, records, files, computer disks, magnetic media, all finished or unfinished documents or material which may be produced or modified by Contractor while performing the Work, whether or not required to be furnished to the City, shall become the property of the City, shall be delivered to the City at its request, and may be used by the City without restriction.

7. PATENTS, COPYRIGHTS, AND RIGHTS IN DATA

7.1 Any patentable result or material suitable for copyright arising out of this Contract shall be owned by and made available to the City for public use, unless the City shall, in a specific case where it is legally permissible, determine that it is in the public interest that it not be so owned or available.

7.2 The Contractor agrees that the ownership of any plans, drawings, designs, specifications, computer programs, technical reports, operating manuals, calculations, notes and other work submitted or which is specified to be delivered under this Contract, whether or not complete (referred to in this subsection as "Subject Data"), is hereby irrevocably transferred and assigned to the City and shall be vested in the City or such other local, state or federal agency, if any, as may be provided by separate contract with the City. The Contractor shall execute and deliver such instruments and take such other action(s) as may be requested by the City to perfect or protect the City's rights to such Subject Data and work product, and to perfect the assignments and transfers contemplated in Sections 6 and 7.

7.3 All such Subject Data furnished by the Contractor pursuant to this Contract, other than documents exclusively for internal use by the City, shall carry such notations on the front cover or a title page (or in such case

of maps, in the same block) as may be requested by the City. The Contractor shall also place their endorsement on all Subject Data furnished by them. All such identification details shall be subject to approval by the City prior to printing.

7.4 The Contractor shall ensure that substantially the foregoing paragraphs in Sections 6 and 7 are included in each subcontract for the work on the Project.

8. GENERAL PROVISIONS

8.1 Entire Contract. The Contract Documents contain all of the agreements of the Parties with respect to any matter covered or mentioned in this Contract and no prior agreements or understandings pertaining to any such matters shall be effective for any purpose. In entering into this Contract, neither party has relied upon any statement, estimate, forecast, projection, representation, warranty, action or agreement of the other party except for those expressly contained in the Contract Documents.

8.2 Documents. The documents incorporated by reference, as if fully set forth in this Contract, are the Notice to Contractors, the Instructions to Bidders and Checklists, the Contractor's Quote (including all forms and supplemental information listed on the Bidders Checklist), the Contract Documents (including Project Plans, Specifications, and all Appendices, Amendments, and Supplemental Reports & Information), the Contract Provisions (including all forms and supplemental information listed on the Contract Checklist), the version of the Washington State Standard Specifications for Road, Bridge, and Municipal Construction identified herein, and any other documents provided to bidders and/or referenced in or referred to by the Contract Documents.

8.3 Modification. No provisions of this Contract, including this provision, may be amended or added to except by agreement in writing signed by the Parties or their respective successors in interest in accordance with the Contract Documents.

8.4 Change Orders. In addition to its rights under the Contract Documents, the City may unilaterally issue a Change Order at any time making changes within the general scope of the Contract, without invalidating the Contract and without providing notice to sureties. The City's issuance of a unilateral Change Order shall not be construed as a waiver of any rights afforded the City, including its right to reject a prior protest or request for change or Claim due to untimeliness or the Contractor's failure to fully comply with the requirements of the Contract Documents, or to void the unilateral Change Order due to unilateral mistake, misrepresentation, or fraud.

8.5 Total Cost Method / Claims. In no event shall a Total Cost Method or a modified Total Cost Method be used by the Contractor to calculate any adjustments to the Contract price. For the purpose of this provision, any cost method, or variety of cost methods, using the difference between the actual cost of the Work and the Bid or Contract price of the Work to calculate any additional compensation or money owed to the Contractor shall be considered a Total Cost Method. In addition, the City shall not be responsible for, and the Contractor shall not be entitled to, any compensation for unallowable costs. Unallowable costs include, but are not limited to: (i) interest or attorneys' fees, except as mandated by statute; (ii) Claim preparation or filing costs; (iii) the costs of preparing notices or protests; (iv) lost profits, lost income, or lost earnings; (v) costs for idle equipment when such equipment is not at the Site, has not been employed in the Work, or is not scheduled to be used at the Site; (vi) claims consulting costs; (vii) expert fees and costs; (viii) loss of other business; and/or (ix) any other special, consequential, expectancy, incidental, or indirect damages incurred by the Contractor, Subcontractors, or suppliers.

8.6 Warranties and Guarantees. In addition to the requirements of the Contract Documents, the Contractor warrants that all portions of the Work that will be covered by a manufacturer's or supplier's guarantee or warranty shall be performed in such a manner so as to preserve all rights under such guarantees or warranties. If the City attempts to enforce a claim based upon a manufacturer's or supplier's guarantee or warranty and such manufacturer or supplier refuses to honor such guarantee or warranty based, in whole or in part, on a claim of defective installation by the Contractor or a Subcontractor, the Contractor shall be responsible for any resulting loss or damage, and repairs, incurred by the City as a result of the manufacturer's or supplier's refusal to honor such guarantee or warranty. This obligation survives termination of this Contract.

8.7 Full Force and Effect. Any provision of this Contract, which is declared invalid, void or illegal, shall in no way affect, impair, or invalidate any other provision hereof and such other provisions shall remain in full force and effect.

8.8 Assignment. The Contractor shall not transfer or assign, in whole or in part, any or all of its obligations and rights hereunder without the prior written consent of the City. In the event the City consents to any such assignment or transfer, such consent shall in no way release the Contractor from any of its obligations or liabilities under this Contract.

8.9 Successors In Interest. Subject to the preceding Subsection, this Contract shall be binding upon and inure to the benefit of the Parties' successors in interest, heirs and assigns.

8.10 Time Limitation and Venue. For the convenience of the parties to the Contract it is mutually agreed by the parties that any claims, causes of action, or disputes which the Contractor has against the City arising from the Contract shall be brought within the following time period: (i) 180 calendar days from the date of Substantial Completion for those claims, causes of action, or disputes arising prior to the date of Substantial Completion, and (ii) 180 calendar days from the date of Final Acceptance of the Contract by the City for those claims, causes of action, or dispute arising after the date of Substantial Completion. It is further agreed that the venue for any claim, cause of action, or dispute related to this Contract shall be King County, Washington, which shall have exclusive jurisdiction over any such case, controversy, or dispute. The parties understand and agree that the Contractor's failure to bring suit within the time period provided, shall be a complete bar to any such claims or causes of action. It is further mutually agreed by the parties that when any claims, causes of action, or disputes which the Contractor asserts against the City arising from the Contract are filed with the City or initiated in court, the Contractor shall permit the City to have timely access to any records deemed necessary by the City to assist in evaluating the claims, action, or dispute.

8.11 No Waiver. Failure of the City to declare any breach or default immediately upon occurrence thereof, or delay in taking any action in connection with, shall not waive such breach or default. Failure of the City to declare one breach or default does not act as a waiver of the City's right to declare another breach or default.

8.12 Sole Authority/Discretion/Judgment. Where the Contract Documents provide the City or its Engineer with "sole" authority, discretion, or judgment, such authority, discretion, or judgment shall be considered unconditional and absolute.

8.13 Governing Law. This Contract shall be made in and shall be governed by and interpreted in accordance with the laws of the State of Washington.

8.14 Authority. Each individual executing this Contract on behalf of the City and Contractor represents and warrants that such individuals are duly authorized to execute and deliver this Contract on behalf of the Contractor or City.

8.15 Engineer. The Engineer is the City's representative who directly supervises the engineering and administration of a construction Contract. The Engineer's authorities, duties, and responsibilities are limited to those specifically identified in the Contract Documents. Designation of an individual or entity as the Engineer for the Project is solely to identify the representative of the City as the entity to act as the Engineer as described in the Contract Documents. Using the term "engineer" does not imply that such entity or person is a licensed professional engineer or an engineering company and does not import any additional obligations upon the actions of the Engineer that may govern licensed professional engineers when performing engineering services.

The Engineer for this Project is designated as: **[STAFF - INSERT NAME OF COMPANY RETAINED TO PERFORM AS THE ENGINEER OR NAME & TITLE OF CFW PROJECT ENGR IF CM SERVICES ARE BEING PROVIDED IN-HOUSE]**

8.16 Notices. Any notices required to be given to Contractor or to the Engineer shall be delivered to the Parties at the addresses set forth below. Any notices may be delivered personally to the addressee of the notice

or may be deposited in the United States mail, postage prepaid, to the address set forth herein. Any notice so posted in the United States mail shall be deemed received three (3) days after the date of mailing.

CONTRACTOR: Company
Attn: Individual to receive notices
Street Address
City, State, Zip

ENGINEER: CM Company OR City of Federal Way
Attn: Project Engineer Attn: Project Engineer
Street Address 33325 8th Ave S
City, State, Zip Federal Way, WA 98003

8.17 Captions. The respective captions of the Sections of this Contract are inserted for convenience of reference only and shall not be deemed to modify or otherwise affect in any respect any of the provisions of this Contract.

8.18 Performance. Time is of the essence of this Contract and each and all of its provisions in which performance is a factor. Adherence to completion dates is essential to the Contractor's performance of this Contract.

8.19 Compliance with Ethics Code. If a violation of the City's Ethics Resolution No. 91-54, as amended, occurs as a result of the formation and/or performance of this Contract, this Contract may be rendered null and void, at the City's option.

9. PERFORMANCE/PAYMENT BOND

Pursuant to RCW 39.08.010, the Contractor's payment and performance bonds must be conditioned upon: (i) faithful performance of all of the provisions of the Contract, including warranty obligations; (ii) the payment of all laborers, mechanics, Subcontractors, and Suppliers, and all persons who supply such persons with provisions or supplies in carrying out the Work; and (iii) payment of any taxes, liabilities, increases, or penalties incurred on the Project under Titles 50, 51, and 82 RCW which may be due on (a) projects referred to in RCW 60.28.011(1)(b), and (b) projects for which the bond is conditioned on the payment of such taxes, liabilities, increases, or penalties. Contractor's obligations under this Contract shall not be limited to the dollar amount of the bond.

Alternatively, pursuant to RCW 39.08.010, at the option of Contractor, if the value of this Contract is less than One Hundred Fifty Thousand Dollars (\$150,000.00), the City may, in lieu of a bond, retain ten percent (10%) of the Contract amount for a period of thirty (30) days after the date of final acceptance, or until receipt of all necessary releases from the Department of Revenue and the Department of Labor and Industries and settlement of any liens filed under Chapter 60.28 RCW, whichever is later. The Contractor must notify the City in writing if it elects to take this alternative.

DATED the day and year set forth above.

CITY OF FEDERAL WAY:

CONTRACTOR:

Jim Ferrell, Mayor
33325 8th Avenue South
Federal Way, WA 98003-6325

Signature of Authorized Individual

Printed Name of Authorized Individual

ATTEST:

EXHIBIT A SAMPLE TASK ORDER



	Contract Name:	Contract Number:	
TASK ORDER No.	TASK ORDER Name:	Date:	
Description of work:			
Estimated Costs:			
Contract Value:	Total Task Costs To Date:	This Task Order Estimate Cost:	Contract Remaining:
Task Order Summary			
Task Order No.	Task Order Name:	Amount	
		\$	
		\$	
		\$	
		\$	
		\$	
Total Contracted to date		\$	

Agreed Upon:

[Contractor's Name]:

By: _____

Name: _____ Date: _____

City of Federal Way:

Task Manager: _____

Name: _____ Date: _____

Contract Manager: _____

Name: _____ Date: _____

Contractor arising out of, or relating in any way to, the Work identified, to be performed, or deleted pursuant to Change Order except as specifically described in this Change Order.

CONTRACTOR'S SIGNATURE

DATE

PUBLIC WORKS DIRECTOR

DATE

*Contract Change Order
provided for Contractor's
reference. Change orders
executed during the project
will use this form.*

CERTIFICATE OF INSURANCE

*Contractor's Certificate of
Insurance to be inserted
here during Contract
Execution*

LOCAL OFFICE/AGENT OF SURETY:

Name

Street Address

City, State, Zip

Telephone

BOND NO.: _____

APPROVED AS TO FORM: _____
J. Ryan Call, City Attorney

CONTRACTOR'S RETAINAGE OPTION

IDENTIFICATION AND DESCRIPTION

Project Title: _____

RFB No: _____

Contractor: _____

GENERAL REQUIREMENTS

1. In accordance with applicable State Statutes, a contract retainage not to exceed five percent of the moneys earned by the contractor will be reserved by the City unless the Contractor elects that the City may retain 10% of the contract amount in lieu of a performance and payment bond pursuant to RCW 39.08.010.
2. All investments selected are subject to City approval.
3. The final disposition of the contract retainage will be made in accordance with applicable State Statutes.

CONTRACTOR'S INSTRUCTIONS

Pursuant to RCW 60.28.011, I hereby notify the City of Federal Way of my instructions for the retainage withheld under the terms of this contract:

- Option 1:** Retained in a fund by the City of Federal Way. No interest will be paid to the contractor.
- Option 2:** Deposited in an interest bearing account in a bank, mutual savings bank, or savings and loan association. Interest paid to the contractor. Contractor shall have the bank (or other) execute a separate "City of Federal Way Retainage Bank Acceptance Agreement" upon contract award. The City will provide the agreement to the Contractor if this option is selected.
- Option 3:** Placed in escrow with a bank or trust company. Contractor shall execute, and have escrow account holder execute a separate "City of Federal Way Construction Retainage Escrow Agreement" upon contract award. The City will provide the agreement to the Contractor if this option is selected. All investments are subject to City approval. The cost of the investment program, and risk thereof, is to be borne entirely by the contractor.
- Option 4:** Contractor shall submit a "Retainage Bond" on City-provided form included in these Contract Documents.

Contractor Signature

Date

RETAINAGE BOND TO CITY OF FEDERAL WAY
ON-CALL SIDEWALK AND CURB REPLACEMENT

KNOW ALL PERSONS BY THESE PRESENTS that we, the undersigned, _____, as principal ("Principal"), and _____, a Corporation organized and existing under the laws of the State of _____, as a surety Corporation, and qualified under the laws of the State of Washington to become surety upon bonds of Contractors with Municipal Corporations, as surety ("Surety"), are jointly and severally held and firmly bonded to the City of Federal Way ("City") in the penal sum of: _____ (\$ _____) for the payment of which sum we bind ourselves and our successors, heirs, administrators or personal representatives, as the case may be.

A. This obligation is entered into in pursuant to the statutes of the State of Washington and the ordinances, regulations, standards and policies of the City, as now existing or hereafter amended or adopted.

B. Pursuant to proper authorization, the Mayor is authorized to enter into a certain contract with the Principal, providing for the above-referenced Project, which contract is incorporated herein by this reference ("Contract"), and

C. Pursuant to State law, Chapter 60.28 RCW, the City is required to reserve from the monies earned by the Principal pursuant to the contract, a sum not to exceed five percent (5%), said sum to be retained by the City as a trust fund for the protection and payment of any person or persons, mechanic, subcontractor or material men who shall perform any labor upon such contract or the doing of such work, and all persons who shall supply such person or persons or subcontractors with provisions and supplies for the carrying on of such work, and the State with the respect to taxes imposed pursuant to Title 82 RCW which may be due from said Principal. Every person performing labor or furnishing supplies towards completion of said improvement or work shall have a lien on said monies so reserved, provided that such notice of the lien of such claimant shall be given in the manner and within the time provided in RCW 39.08.030 as now existing and in accordance with any amendments that may hereafter be provided thereto; and

D. State law further provides that with the consent of the City, the Principal may submit a bond for all or any portion of the amount of funds retained by the public body in a form acceptable to the public body conditioned upon such bond any proceeds therefrom being made subject to all claims and liens and in the same manner and priority as set forth retained percentages pursuant to Chapter 60.28 RCW; and

E. The Principal has accepted, or is about to accept, the Contract, and undertake to perform the work therein provided for in the manner and within the time set forth, for the amount of \$ _____; and

F. The City is prepared to release any required retainage money previously paid by the Principal prior to acceptance and successful operation and fulfillment of all other terms of said contract upon being indemnified by these presents,

NOW, THEREFORE, if the Principal shall perform all the provisions of the Contract in the manner and within the time period prescribed by the City, or within such extensions of time as may be granted under the Contract, and shall pay all laborers, mechanics, subcontractors and material men or women, and all persons who shall supply the Principal or subcontractors with provisions and supplies for the carrying on of said work, and if the Principal shall pay to the State all taxes imposed pursuant to Title 82 RCW which may be due from such Principal as a result of this contract then and in the event this obligation shall be void; but otherwise it shall be and remain in full force and effect.

And the Surety, for value received, hereby further stipulates and agrees that no change, extension of time, alteration or addition to the terms of the Contract or to the work to be performed thereunder or the specifications accompanying the same shall in any way affect its obligation on this bond, and it does hereby waive notice of any change, extension of time, alterations or additions to the terms of the Contract or to the Work.

The Surety hereby agrees that modifications and changes may be made in the terms and provisions of the Contract without notice to Surety, and any such modifications or changes increasing the total amount to be paid the Principal shall automatically increase the obligation of the Surety on this Retainage Bond in a like amount, such increase, however, not to exceed twenty-five percent (25%) of the original amount of this bond without consent of the Surety.

Within forty-five (45) days of receiving notice that the Principal has defaulted on all or part of the terms of the Contract, the Surety shall make written commitment to the City that it will either: (a) cure the default itself within a reasonable time period, or (b) tender to the City, the amount necessary for the City to remedy the default, including legal fees incurred by the City, or (c) in the event that Surety's evaluation of the dispute is not complete or in the event the Surety disputes the City's claim of default, the Surety shall notify the City of its finding and its intent, if any, to interplead. The Surety shall then fulfill its obligations under this bond, according to the option it has elected. Should Surety elect option (a) to cure the default, the penal sum of the Bond shall be reduced in an amount equal to the costs actually incurred by the Surety in curing the default. If the Surety elects option (b), then upon completion of the necessary work, the City shall notify the Surety of its actual costs. The City shall return, without interest, any overpayment made by the Surety and the Surety shall pay to the City any actual costs which exceed the City estimate, limited to the bond amount. Should the Surety elect option (c), the Parties shall first complete participation in mediation, described in the below paragraph, prior to any interplead action.

In the event a dispute should arise between the Parties to this Bond with respect to the City's declaration of default by the Principal, the Parties agree to participate in at least four hours of mediation to resolve said dispute. The Parties shall proportionately share in the cost of the mediation. The mediation shall be administered by Judicial Dispute Resolution, LLC, 1425 Fourth Avenue, Suite 300, Seattle, Washington 98101. The Surety shall not interplead prior to completion of the mediation.

The parties have executed this instrument under their separate seals this ____ day of _____, 20____, the name and corporate seal of each corporate party hereto affixed, and these presents duly signed by its undersigned representatives pursuant to authority of its governing body.

CORPORATE SEAL:

PRINCIPAL:

By: _____

Title: _____

Address: _____

CORPORATE SEAL:

SURETY:

By: _____

*Attorney-in-Fact
(Attach Power of Attorney)*

Title: _____

Address: _____

CERTIFICATES AS TO CORPORATE SEAL

I hereby certify that I am the (Assistant) Secretary of the Corporation named as Principal in the within bond; that _____, who signed the said bond on behalf of the Principal, was _____ of said Corporation; that I know his or her signature thereto is genuine, and that said bond was duly signed, sealed, and attested for and in behalf of said Corporation by authority of its governing body.

Secretary of Principal

I hereby certify that I am the (Assistant) Secretary of the Corporation named as Surety in the within bond; that _____, who signed the said bond on behalf of the Surety, was _____ of the said Corporation; that I know his or her signature thereto is genuine, and that said bond was duly signed, sealed, and attested for and in behalf of said Corporation by authority of its governing body.

Secretary of Surety

APPROVED AS TO FORM:

J. Ryan Call, City Attorney

Benefit Code Key – Effective 8/31/2023 thru 3/1/2024

Overtime Codes

Overtime calculations are based on the hourly rate actually paid to the worker. On public works projects, the hourly rate must be not less than the prevailing rate of wage minus the hourly rate of the cost of fringe benefits actually provided for the worker.

1. ALL HOURS WORKED IN EXCESS OF EIGHT (8) HOURS PER DAY OR FORTY (40) HOURS PER WEEK SHALL BE PAID AT ONE AND ONE-HALF TIMES THE HOURLY RATE OF WAGE.
 - B. All hours worked on Saturdays shall be paid at one and one-half times the hourly rate of wage. All hours worked on Sundays and holidays shall be paid at double the hourly rate of wage.
 - C. The first two (2) hours after eight (8) regular hours Monday through Friday and the first ten (10) hours on Saturday shall be paid at one and one-half times the hourly rate of wage. All other overtime hours and all hours worked on Sundays and holidays shall be paid at double the hourly rate of wage.
 - D. The first two (2) hours before or after a five-eight (8) hour workweek day or a four-ten (10) hour workweek day and the first eight (8) hours worked the next day after either workweek shall be paid at one and one-half times the hourly rate of wage. All additional hours worked and all worked on Sundays and holidays shall be paid at double the hourly rate of wage.
 - E. The first two (2) hours after eight (8) regular hours Monday through Friday and the first eight (8) hours on Saturday shall be paid at one and one-half times the hourly rate of wage. All other hours worked Monday through Saturday, and all hours worked on Sundays and holidays shall be paid at double the hourly rate of wage.
 - F. The first two (2) hours after eight (8) regular hours Monday through Friday and the first ten (10) hours on Saturday shall be paid at one and one-half times the hourly rate of wage. All other overtime hours worked, except Labor Day, shall be paid at double the hourly rate of wage. All hours worked on Labor Day shall be paid at three times the hourly rate of wage.
 - G. The first ten (10) hours worked on Saturdays and the first ten (10) hours worked on a fifth calendar weekday in a four-ten hour schedule, shall be paid at one and one-half times the hourly rate of wage. All hours worked in excess of ten (10) hours per day Monday through Saturday and all hours worked on Sundays and holidays shall be paid at double the hourly rate of wage.
 - H. All hours worked on Saturdays (except makeup days if work is lost due to inclement weather conditions or equipment breakdown) shall be paid at one and one-half times the hourly rate of wage. All hours worked Monday through Saturday over twelve (12) hours and all hours worked on Sundays and holidays shall be paid at double the hourly rate of wage.
 - I. All hours worked on Sundays and holidays shall also be paid at double the hourly rate of wage.
 - J. The first two (2) hours after eight (8) regular hours Monday through Friday and the first ten (10) hours on Saturday shall be paid at one and one-half times the hourly rate of wage. All hours worked over ten (10) hours Monday through Saturday, Sundays and holidays shall be paid at double the hourly rate of wage.
 - K. All hours worked on Saturdays and Sundays shall be paid at one and one-half times the hourly rate of wage. All hours worked on holidays shall be paid at double the hourly rate of wage.
 - M. All hours worked on Saturdays (except makeup days if work is lost due to inclement weather conditions) shall be paid at one and one-half times the hourly rate of wage. All hours worked on Sundays and holidays shall be paid at double the hourly rate of wage.
 - N. All hours worked on Saturdays (except makeup days) shall be paid at one and one-half times the hourly rate of wage. All hours worked on Sundays and holidays shall be paid at double the hourly rate of wage.

Overtime Codes Continued

1. O. The first ten (10) hours worked on Saturday shall be paid at one and one-half times the hourly rate of wage. All hours worked on Sundays, holidays and after twelve (12) hours, Monday through Friday and after ten (10) hours on Saturday shall be paid at double the hourly rate of wage.
- P. All hours worked on Saturdays (except makeup days if circumstances warrant) and Sundays shall be paid at one and one-half times the hourly rate of wage. All hours worked on holidays shall be paid at double the hourly rate of wage.
- Q. The first two (2) hours after eight (8) regular hours Monday through Friday and up to ten (10) hours worked on Saturdays shall be paid at one and one-half times the hourly rate of wage. All hours worked in excess of ten (10) hours per day Monday through Saturday and all hours worked on Sundays and holidays (except Christmas day) shall be paid at double the hourly rate of wage. All hours worked on Christmas day shall be paid at two and one-half times the hourly rate of wage.
- R. All hours worked on Sundays and holidays shall be paid at two times the hourly rate of wage.
- U. All hours worked on Saturdays shall be paid at one and one-half times the hourly rate of wage. All hours worked on Sundays and holidays (except Labor Day) shall be paid at two times the hourly rate of wage. All hours worked on Labor Day shall be paid at three times the hourly rate of wage.
- V. All hours worked on Sundays and holidays (except Thanksgiving Day and Christmas day) shall be paid at one and one-half times the hourly rate of wage. All hours worked on Thanksgiving Day and Christmas day shall be paid at double the hourly rate of wage.
- W. All hours worked on Saturdays and Sundays (except make-up days due to conditions beyond the control of the employer) shall be paid at one and one-half times the hourly rate of wage. All hours worked on holidays shall be paid at double the hourly rate of wage.
- X. The first four (4) hours after eight (8) regular hours Monday through Friday and the first twelve (12) hours on Saturday shall be paid at one and one-half times the hourly rate of wage. All hours worked over twelve (12) hours Monday through Saturday, Sundays and holidays shall be paid at double the hourly rate of wage. When holiday falls on Saturday or Sunday, the day before Saturday, Friday, and the day after Sunday, Monday, shall be considered the holiday and all work performed shall be paid at double the hourly rate of wage.
- Y. All hours worked outside the hours of 5:00 am and 5:00 pm (or such other hours as may be agreed upon by any employer and the employee) and all hours worked in excess of eight (8) hours per day (10 hours per day for a 4 x 10 workweek) and on Saturdays and holidays (except labor day) shall be paid at one and one-half times the hourly rate of wage. (except for employees who are absent from work without prior approval on a scheduled workday during the workweek shall be paid at the straight-time rate until they have worked 8 hours in a day (10 in a 4 x 10 workweek) or 40 hours during that workweek.) All hours worked Monday through Saturday over twelve (12) hours and all hours worked on Sundays and Labor Day shall be paid at double the hourly rate of wage.
- Z. All hours worked on Saturdays and Sundays shall be paid at one and one-half times the hourly rate of wage. All hours worked on holidays shall be paid the straight time rate of pay in addition to holiday pay.

Overtime Codes Continued

2. ALL HOURS WORKED IN EXCESS OF EIGHT (8) HOURS PER DAY OR FORTY (40) HOURS PER WEEK SHALL BE PAID AT ONE AND ONE-HALF TIMES THE HOURLY RATE OF WAGE.
- B. All hours worked on holidays shall be paid at one and one-half times the hourly rate of wage.
 - F. The first eight (8) hours worked on holidays shall be paid at the straight hourly rate of wage in addition to the holiday pay. All hours worked in excess of eight (8) hours on holidays shall be paid at double the hourly rate of wage.
 - M. This code appears to be missing. All hours worked on Saturdays, Sundays and holidays shall be paid at double the hourly rate of wage.
 - R. All hours worked on Sundays and holidays and all hours worked over sixty (60) in one week shall be paid at double the hourly rate of wage.
 - U. All hours worked on Saturdays shall be paid at one and one-half times the hourly rate of wage. All hours worked over 12 hours in a day or on Sundays and holidays shall be paid at double the hourly rate of wage.
3. ALL HOURS WORKED IN EXCESS OF EIGHT (8) HOURS PER DAY OR FORTY (40) HOURS PER WEEK SHALL BE PAID AT ONE AND ONE-HALF TIMES THE HOURLY RATE OF WAGE.
- F. All hours worked on Saturday shall be paid at one and one-half times the hourly rate of wage. All hours worked on Sunday shall be paid at two times the hourly rate of wage. All hours worked on paid holidays shall be paid at two and one-half times the hourly rate of wage including holiday pay.
 - H. All work performed on Sundays between March 16th and October 14th and all Holidays shall be compensated for at two (2) times the regular rate of pay. Work performed on Sundays between October 15th and March 15th shall be compensated at one and one half (1-1/2) times the regular rate of pay.
 - J. All hours worked between the hours of 10:00 pm and 5:00 am, Monday through Friday, and all hours worked on Saturdays shall be paid at a one and one-half times the hourly rate of wage. All hours worked on Sundays and holidays shall be paid at double the hourly rate of wage.
 - K. Work performed in excess of eight (8) hours of straight time per day, or ten (10) hours of straight time per day when four ten (10) hour shifts are established, or forty (40) hours of straight time per week, Monday through Friday, or outside the normal 5 am to 6pm shift, and all work on Saturdays shall be paid at one and one-half times the hourly rate of wage. All work performed after 6:00 pm Saturday to 5:00 am Monday and Holidays, and all hours worked in excess of twelve (12) hours in a single shift shall be paid at double the hourly rate of wage.

After an employee has worked eight (8) hours at an applicable overtime rate, all additional hours shall be at the applicable overtime rate until such time as the employee has had a break of eight (8) hours or more. When an employee returns to work without at least eight (8) hours time off since their previous shift, all such time shall be a continuation of shift and paid at the applicable overtime rate until he/she shall have the eight (8) hours rest period.

Overtime Codes Continued

4. ALL HOURS WORKED IN EXCESS OF EIGHT (8) HOURS PER DAY OR FORTY (40) HOURS PER WEEK SHALL BE PAID AT ONE AND ONE-HALF TIMES THE HOURLY RATE OF WAGE.

- A. All hours worked in excess of eight (8) hours per day or forty (40) hours per week shall be paid at double the hourly rate of wage. All hours worked on Saturdays, Sundays and holidays shall be paid at double the hourly rate of wage
- C. On Monday through Friday, the first four (4) hours of overtime after eight (8) hours of straight time work shall be paid at one and one half (1-1/2) times the straight time rate of pay, unless a four (4) day ten (10) hour workweek has been established. On a four (4) day ten (10) hour workweek scheduled Monday through Thursday, or Tuesday through Friday, the first two (2) hours of overtime after ten (10) hours of straight time work shall be paid at one and one half (1-1/2) times the straight time rate of pay. On Saturday, the first twelve (12) hours of work shall be paid at one and one half (1-1/2) times the straight time rate of pay, except that if the job is down on Monday through Friday due to weather conditions or other conditions outside the control of the employer, the first ten (10) hours on Saturday may be worked at the straight time rate of pay. All hours worked over twelve (12) hours in a day and all hours worked on Sunday and Holidays shall be paid at two (2) times the straight time rate of pay.
- D. All hours worked in excess of eight (8) hours per day or forty (40) hours per week shall be paid at double the hourly rate of wage. All hours worked on Saturday, Sundays and holidays shall be paid at double the hourly rate of pay. Rates include all members of the assigned crew.

EXCEPTION:

On all multipole structures and steel transmission lines, switching stations, regulating, capacitor stations, generating plants, industrial plants, associated installations and substations, except those substations whose primary function is to feed a distribution system, will be paid overtime under the following rates:

The first two (2) hours after eight (8) regular hours Monday through Friday of overtime on a regular workday, shall be paid at one and one-half times the hourly rate of wage. All hours in excess of ten (10) hours will be at two (2) times the hourly rate of wage. The first eight (8) hours worked on Saturday will be paid at one and one-half (1-1/2) times the hourly rate of wage. All hours worked in excess of eight (8) hours on Saturday, and all hours worked on Sundays and holidays will be at the double the hourly rate of wage.

All overtime eligible hours performed on the above described work that is energized, shall be paid at the double the hourly rate of wage.

- E. The first two (2) hours after eight (8) regular hours Monday through Friday and the first eight (8) hours on Saturday shall be paid at one and one-half times the hourly rate of wage. All other hours worked Monday through Saturday, and all hours worked on Sundays and holidays shall be paid at double the hourly rate of wage.

On a four-day, ten-hour weekly schedule, either Monday thru Thursday or Tuesday thru Friday schedule, all hours worked after ten shall be paid at double the hourly rate of wage. The Monday or Friday not utilized in the normal four-day, ten hour work week, and Saturday shall be paid at one and one half (1½) times the regular shift rate for the first eight (8) hours. All other hours worked Monday through Saturday, and all hours worked on Sundays and holidays shall be paid at double the hourly rate of wage.
- G. All hours worked on Saturdays shall be paid at one and one-half times the hourly rate of wage. All hours worked Monday through Saturday over twelve (12) hours and all hours worked on Sundays and holidays shall be paid at double the hourly rate of wage.
- I. The First eight (8) hours worked on Saturdays shall be paid at one and one-half times the hourly rate of wage. All hours worked in excess of eight (8) per day on Saturdays shall be paid at double the hourly rate of wage. All hours worked on Sundays and holidays shall be paid at double the hourly rate of wage.

Overtime Codes Continued

4. J. The first eight (8) hours worked on a Saturday shall be paid at one and one-half times the hourly rate of wage. All hours worked in excess of eight (8) hours on a Saturday shall be paid at double the hourly rate of wage. All hours worked over twelve (12) in a day, and all hours worked on Sundays and Holidays shall be paid at double the hourly rate of wage.
- K. All hours worked on a Saturday shall be paid at one and one-half times the hourly rate of wage, so long as Saturday is the sixth consecutive day worked. All hours worked over twelve (12) in a day Monday through Saturday, and all hours worked on Sundays and Holidays shall be paid at double the hourly rate of wage.
- L. The first twelve (12) hours worked on a Saturday shall be paid at one and one-half times the hourly rate of wage. All hours worked on a Saturday in excess of twelve (12) hours shall be paid at double the hourly rate of pay. All hours worked over twelve (12) in a day Monday through Friday, and all hours worked on Sundays shall be paid at double the hourly rate of wage. All hours worked on a holiday shall be paid at one and one-half times the hourly rate of wage, except that all hours worked on Labor Day shall be paid at double the hourly rate of pay.
- S. On a four (4) day ten (10) hour workweek scheduled Monday through Thursday, or Tuesday through Friday, work performed in excess of (10) hours shall be paid at one and one half (1-1/2) times the hourly rate of pay. On Monday through Friday, work performed outside the normal work hours of 6:00 a.m. and 6:00 p.m. shall be paid at one and one-half (1-1/2) times the straight time rate, (except for special shifts or multiple shift operations).
- All hours worked on Saturdays shall be paid at one and one-half times the hourly rate of wage. All work performed on Sundays and holidays shall be paid at double the hourly rate of wage. When an employee returns to work without at least eight (8) hours time off since their previous shift, all such time shall be a continuation of shift and paid at the applicable overtime rate until such time as the employee has had a break of eight (8) hours.
- Multiple Shift Operations: When the first shift of a multiple shift (a two or three shift) operation is started at the basic straight time rate or at a specific overtime rate, all shifts of that day's operation shall be completed at that rate. Special Shifts: The Special Shift Premium is the basic hourly rate of pay plus \$2.00 an hour. When due to conditions beyond the control of the employer or when an owner (not acting as the contractor), a government agency or the contract specifications require more than four (4) hours of a special shift can only be performed outside the normal 6am to 6pm shift then the special shift premium will be applied to the basic straight time for the entire shift. When an employee works on a special shift, they shall be paid the special shift premium for each hour worked unless they are in overtime or double-time status. (For example, the special shift premium does not waive the overtime requirements for work performed on Saturday or Sunday).
- U. The first four (4) hours after eight (8) regular hours Monday through Friday and the first twelve (12) hours on Saturday shall be paid at one and one-half times the hourly rate of wage. (Except on makeup days if work is lost due to inclement weather, then the first eight (8) hours on Saturday may be paid the regular rate.) All hours worked over twelve (12) hours Monday through Saturday, and all hours worked on Sundays and holidays shall be paid at double the hourly rate of wage.

Overtime Codes Continued

4. V. Work performed in excess of ten (10) hours of straight time per day when four ten (10) hour shifts are established or outside the normal shift (5 am to 6pm), and all work on Saturdays, except for make-up days shall be paid at time and one-half (1 ½) the straight time rate.

In the event the job is down due to weather conditions, then Saturday may, be worked as a voluntary make-up day at the straight time rate. However, Saturday shall not be utilized as a make-up day when a holiday falls on Friday. All work performed on Sundays and holidays and work in excess of twelve (12) hours per day shall be paid at double (2x) the straight time rate of pay.

After an employee has worked eight (8) hours at an applicable overtime rate, all additional hours shall be at the applicable overtime rate until such time as the employee has had a break of eight (8) hours.

When an employee returns to work without a break of eight (8) hours since their previous shift, all such time shall be a continuation of shift and paid at the applicable overtime rate until such time as the employee has had a break of eight (8) hours.

- X. All hours worked on Saturdays shall be paid at one and one-half times the hourly rate of wage. All hours worked on Sundays and holidays shall be paid at double the hourly rate of wage. Work performed outside the normal shift of 6 am to 6pm shall be paid at one and one-half the straight time rate, (except for special shifts or three shift operations). All work performed on Sundays and holidays shall be paid at double the hourly rate of wage. Shifts may be established when considered necessary by the Employer.

The Employer may establish shifts consisting of eight (8) or ten (10) hours of work (subject to WAC 296-127-022), that shall constitute a normal forty (40) hour work week. The Employer can change from a 5-eight to a 4-ten hour schedule or back to the other. All hours of work on these shifts shall be paid for at the straight time hourly rate. Work performed in excess of eight hours (or ten hours per day (subject to WAC 296-127-022) shall be paid at one and one-half the straight time rate.

When due to conditions beyond the control of the Employer, or when contract specifications require that work can only be performed outside the regular day shift, then by mutual agreement a special shift may be worked at the straight time rate, eight (8) hours work for eight (8) hours pay. The starting time shall be arranged to fit such conditions of work.

When an employee returns to work without at a break of eight (8) hours since their previous shift, all such time shall be a continuation of shift and paid at the applicable overtime rate until such time as the employee has had a break of eight (8) hours.

11. ALL HOURS WORKED IN EXCESS OF EIGHT (8) HOURS PER DAY OR FORTY (40) HOURS PER WEEK SHALL BE PAID AT ONE AND ONE-HALF TIMES THE HOURLY RATE OF WAGE.

- B After an employee has worked eight (8) hours, all additional hours worked shall be paid at the applicable overtime rate until such time as the employee has had a break of eight (8) hours or more.

- C The first two (2) hours after eight (8) regular hours Monday through Friday and the first eight (8) hours on Saturday shall be paid at one and one-half times the hourly rate of wage. All other overtime hours worked, except Labor Day, and all hours on Sunday shall be paid at double the hourly rate of wage. All hours worked on Labor Day shall be paid at three times the hourly rate of wage. All non-overtime and non-holiday hours worked between 4:00 pm and 5:00 am, Monday through Friday, shall be paid at a premium rate of 15% over the hourly rate of wage.

Overtime Codes Continued

11. D. All hours worked on Saturdays and holidays shall be paid at one and one-half times the hourly rate of wage. All hours worked on Sundays shall be paid at double the hourly rate of wage.
- After an employee has worked eight (8) hours, all additional hours worked shall be paid at the applicable overtime rate until such time as the employee has had a break of eight (8) hours or more.
- E. The first two (2) hours after eight (8) regular hours Monday through Friday, the first ten (10) hours on Saturday, and the first ten (10) hours worked on Holidays shall be paid at one and one-half times the hourly rate of wage. All hours worked over ten (10) hours Monday through Saturday, and Sundays shall be paid at double the hourly rate of wage.
- After an employee has worked eight (8) hours, all additional hours worked shall be paid at the applicable overtime rate until such time as the employee has had a break of eight (8) hours or more.
- F. The first two (2) hours after eight (8) regular hours Monday through Friday and the first eight (8) hours on Saturday shall be paid at one and one-half times the hourly rate of wage. All other hours worked Monday through Saturday, and all hours worked on Sundays and holidays shall be paid at double the hourly rate of wage.
- On a four-day, ten-hour weekly schedule, either Monday thru Thursday or Tuesday thru Friday schedule, all hours worked after ten shall be paid at double the hourly rate of wage. The Monday or Friday not utilized in the normal four-day, ten hour work week, and Saturday shall be paid at one-half times the hourly rate of wage for the first eight (8) hours. All other hours worked Monday through Saturday, and all hours worked on Sundays and holidays shall be paid at double the hourly rate of wage.
- G. Work performed in excess of eight (8) hours of straight time per day, or ten (10) hours of straight time per day when four ten (10) hour shifts are established, or forty (40) hours of straight time per week, Monday through Friday, or outside the normal 5 am to 6pm shift, and all work on Saturdays shall be paid at one and one-half times the hourly rate of wage.
- All work performed after 6:00 pm Saturday to 5:00 am Monday and Holidays, and all hours worked in excess of twelve (12) hours in a single shift shall be paid at double the hourly rate of wage.
- After an employee has worked eight (8) hours at an applicable overtime rate, all additional hours shall be at the applicable overtime rate until such time as the employee has had a break of nine (9) hours or more. When an employee returns to work without at least nine (9) hours time off since their previous shift, all such time shall be a continuation of shift and paid at the applicable overtime rate until he/she shall have the nine (9) hours rest period.
- H. Work performed in excess of eight (8) hours of straight time per day, or ten (10) hours of straight time per day when four ten (10) hour shifts are established, or forty (40) hours of straight time per week, Monday through Friday, or outside the normal 5 am to 6pm shift, and all work on Saturdays shall be paid at one and one-half times the hourly rate of wage.
- All work performed after 6:00 pm Saturday to 5:00 am Monday and Holidays, and all hours worked in excess of twelve (12) hours in a single shift shall be paid at double the hourly rate of wage.
- After an employee has worked eight (8) hours at an applicable overtime rate, all additional hours shall be at the applicable overtime rate until such time as the employee has had a break of ten (10) hours or more. When an employee returns to work without at least ten (10) hours time off since their previous shift, all such time shall be a continuation of shift and paid at the applicable overtime rate until he/she shall have the ten (10) hours rest period.

Overtime Codes Continued

11. J. All hours worked on holidays shall be paid at double the hourly rate of wage.
- K. On Monday through Friday hours worked outside 4:00 am and 5:00 pm, and the first two (2) hours after eight (8) hours worked shall be paid at one and one-half times the hourly rate. All hours worked over 10 hours per day Monday through Friday, and all hours worked on Saturdays, Sundays, and Holidays worked shall be paid at double the hourly rate of wage.
- L. An employee working outside 5:00 am and 5:00 pm shall receive an additional two dollar (\$2.00) per hour for all hours worked that shift. All hours worked on holidays shall be paid at one and one-half times the hourly rate of wage. All hours worked on holidays shall be paid at one and one-half times the hourly rate of wage.
- M. On Monday through Friday, the first four (4) hours of overtime after eight (8) hours of straight time work shall be paid at one and one half (1-1/2) times the straight time rate of pay, unless a four (4) day ten (10) hour workweek has been established. On a four (4) day ten (10) hour workweek scheduled Monday through Thursday, or Tuesday through Friday, the first two (2) hours of overtime after ten (10) hours of straight time work shall be paid at one and one half (1-1/2) times the straight time rate of pay.
- Work performed outside the normal work hours of 5:00 a.m. and 6:00 p.m. shall be paid at one and one-half (1-1/2) times the straight time rate, (except for special shifts or multiple shift operations). When the first shift of a multiple shift (a two or three shift) operation is started at the basic straight time rate or at a specific overtime rate, all shifts of that day's operation shall be completed at that rate. When due to conditions beyond the control of the Employer or when contract specifications require that work can only be performed outside the regular day shift of 5:00 am to 6:00 pm, then a special shift may be worked at the straight time rate, plus the shift pay premium when applicable. The starting time of work will be arranged to fit such conditions of work. Such shift shall consist of eight (8) hours work for eight (8) hours pay or ten (10) hours work for ten (10) hours pay for four ten shifts.
- On Saturday, the first twelve (12) hours of work shall be paid at one and one half (1-1/2) times the straight time rate of pay. All work performed after 6:00 pm Saturday to 5:00 am Monday, all work performed over twelve (12) hours, and all work performed on holidays shall be paid at double the straight time rate of pay.
- Shift Pay Premium: In an addition to any overtime already required, all hours worked between the hours of 6:00 pm and 5:00 am shall receive an additional two dollars (\$2.00) per hour.
- N. All work performed over twelve hours in a shift and all work performed on Sundays and Holidays shall be paid at double the straight time rate.
- Any time worked over eight (8) hours on Saturday shall be paid double the straight time rate, except employees assigned to work six 10-hour shifts per week shall be paid double the straight time rate for any time worked on Saturday over 10 hours.
- O. All work performed on Saturdays, Sundays, and Holidays shall be paid at one and one half (1-1/2) times the straight time rate of pay.

Benefit Code Key – Effective 8/31/2023 thru 3/1/2024

Holiday Codes

- 5. A. Holidays: New Year's Day, Memorial Day, Independence Day, Labor Day, Thanksgiving Day, Friday after Thanksgiving Day, and Christmas Day (7).
- B. Holidays: New Year's Day, Memorial Day, Independence Day, Labor Day, Thanksgiving Day, Friday after Thanksgiving Day, the day before Christmas, and Christmas Day (8).
- C. Holidays: New Year's Day, Presidents' Day, Memorial Day, Independence Day, Labor Day, Thanksgiving Day, the Friday after Thanksgiving Day, And Christmas Day (8).
- D. Holidays: New Year's Day, Memorial Day, Independence Day, Labor Day, Thanksgiving Day, the Friday and Saturday after Thanksgiving Day, And Christmas Day (8).
- H. Holidays: New Year's Day, Memorial Day, Independence Day, Thanksgiving Day, the Day after Thanksgiving Day, And Christmas (6).
- I. Holidays: New Year's Day, Memorial Day, Independence Day, Labor Day, Thanksgiving Day, and Christmas Day (6).
- K. Holidays: New Year's Day, Presidents' Day, Memorial Day, Independence Day, Labor Day, Thanksgiving Day, Friday After Thanksgiving Day, The Day Before Christmas, And Christmas Day (9).
- L. Holidays: New Year's Day, Martin Luther King Jr. Day, Memorial Day, Independence Day, Labor Day, Thanksgiving Day, Friday after Thanksgiving Day, And Christmas Day (8).
- N. Holidays: New Year's Day, Presidents' Day, Memorial Day, Independence Day, Labor Day, Veterans' Day, Thanksgiving Day, The Friday After Thanksgiving Day, And Christmas Day (9).
- P. Holidays: New Year's Day, Memorial Day, Independence Day, Labor Day, Thanksgiving Day, Friday And Saturday After Thanksgiving Day, The Day Before Christmas, And Christmas Day (9). If A Holiday Falls On Sunday, The Following Monday Shall Be Considered As A Holiday.
- Q. Paid Holidays: New Year's Day, Memorial Day, Independence Day, Labor Day, Thanksgiving Day, and Christmas Day (6).
- R. Paid Holidays: New Year's Day, Memorial Day, Independence Day, Labor Day, Thanksgiving Day, Day After Thanksgiving Day, One-Half Day Before Christmas Day, And Christmas Day. (7 1/2).
- S. Paid Holidays: New Year's Day, Presidents' Day, Memorial Day, Independence Day, Labor Day, Thanksgiving Day, And Christmas Day (7).
- Z. Holidays: New Year's Day, Memorial Day, Independence Day, Labor Day, Veterans Day, Thanksgiving Day, the Friday after Thanksgiving Day, And Christmas Day (8).
- 6. G. Paid Holidays: New Year's Day, Martin Luther King Jr. Day, Presidents' Day, Memorial Day, Independence Day, Labor Day, Veterans' Day, Thanksgiving Day, the Friday after Thanksgiving Day, Christmas Day, and Christmas Eve Day (11).
- H. Paid Holidays: New Year's Day, New Year's Eve Day, Memorial Day, Independence Day, Labor Day, Thanksgiving Day, Friday After Thanksgiving Day, Christmas Day, The Day After Christmas, And A Floating Holiday (10).

Benefit Code Key – Effective 8/31/2023 thru 3/1/2024

Holiday Codes Continued

6. T. Paid Holidays: New Year's Day, Presidents' Day, Memorial Day, Independence Day, Labor Day, Thanksgiving Day, The Friday After Thanksgiving Day, The Last Working Day Before Christmas Day, And Christmas Day (9).
- Z. Holidays: New Year's Day, Memorial Day, Independence Day, Labor Day, Thanksgiving Day, Friday after Thanksgiving Day, And Christmas Day (7). If a holiday falls on Saturday, the preceding Friday shall be considered as the holiday. If a holiday falls on Sunday, the following Monday shall be considered as the holiday.
7. A. Holidays: New Year's Day, Memorial Day, Independence Day, Labor Day, Thanksgiving Day, the Friday and Saturday after Thanksgiving Day, And Christmas Day (8). Any Holiday Which Falls On A Sunday Shall Be Observed As A Holiday On The Following Monday. If any of the listed holidays falls on a Saturday, the preceding Friday shall be a regular work day.
- B. Holidays: New Year's Day, Memorial Day, Independence Day, Labor Day, Thanksgiving Day, the Friday and Saturday after Thanksgiving Day, And Christmas Day (8). Any holiday which falls on a Sunday shall be observed as a holiday on the following Monday. Any holiday which falls on a Saturday shall be observed as a holiday on the preceding Friday.
- C. Holidays: New Year's Day, Martin Luther King Jr. Day, Memorial Day, Independence Day, Labor Day, Thanksgiving Day, the Friday after Thanksgiving Day, And Christmas Day (8). Any holiday which falls on a Sunday shall be observed as a holiday on the following Monday. Any holiday which falls on a Saturday shall be observed as a holiday on the preceding Friday.
- D. Paid Holidays: New Year's Day, Memorial Day, Independence Day, Labor Day, Veteran's Day, Thanksgiving Day, the Friday after Thanksgiving Day, And Christmas Day (8). Unpaid Holidays: President's Day. Any paid holiday which falls on a Sunday shall be observed as a holiday on the following Monday. Any paid holiday which falls on a Saturday shall be observed as a holiday on the preceding Friday.
- E. Holidays: New Year's Day, Memorial Day, Independence Day, Labor Day, Thanksgiving Day, the Friday after Thanksgiving Day, And Christmas Day (7). Any holiday which falls on a Sunday shall be observed as a holiday on the following Monday. Any holiday which falls on a Saturday shall be observed as a holiday on the preceding Friday.
- F. Holidays: New Year's Day, Memorial Day, Independence Day, Labor Day, Thanksgiving Day, the Friday after Thanksgiving Day, the last working day before Christmas day and Christmas day (8). Any holiday which falls on a Sunday shall be observed as a holiday on the following Monday. Any holiday which falls on a Saturday shall be observed as a holiday on the preceding Friday.
- G. Holidays: New Year's Day, Memorial Day, Independence Day, Labor Day, Thanksgiving Day, and Christmas Day (6). Any holiday which falls on a Sunday shall be observed as a holiday on the following Monday.
- H. Holidays: New Year's Day, Martin Luther King Jr. Day, Independence Day, Memorial Day, Labor Day, Thanksgiving Day, the Friday after Thanksgiving Day, the Last Working Day before Christmas Day and Christmas Day (9). Any holiday which falls on a Sunday shall be observed as a holiday on the following Monday. Any holiday which falls on a Saturday shall be observed as a holiday on the preceding Friday.
- I. Holidays: New Year's Day, President's Day, Independence Day, Memorial Day, Labor Day, Thanksgiving Day, The Friday After Thanksgiving Day, The Day Before Christmas Day And Christmas Day (9). Any holiday which falls on a Sunday shall be observed as a holiday on the following Monday. Any holiday which falls on a Saturday shall be observed as a holiday on the preceding Friday.

Holiday Codes Continued

7. J. Holidays: New Year's Day, Independence Day, Memorial Day, Labor Day, Thanksgiving Day and Christmas Day (6). Any holiday which falls on a Sunday shall be observed as a holiday on the following Monday. Any holiday which falls on a Saturday shall be observed as a holiday on the preceding Friday.
- K. Holidays: New Year's Day, Memorial Day, Independence Day, Thanksgiving Day, the Friday and Saturday after Thanksgiving Day, And Christmas Day (8). Any holiday which falls on a Sunday shall be observed as a holiday on the following Monday. Any holiday which falls on a Saturday shall be observed as a holiday on the preceding Friday.
- L. Holidays: New Year's Day, Memorial Day, Labor Day, Independence Day, Thanksgiving Day, the Last Work Day before Christmas Day, And Christmas Day (7). Any holiday which falls on a Sunday shall be observed as a holiday on the following Monday. Any holiday which falls on a Saturday shall be observed as a holiday on the preceding Friday.
- N. Holidays: New Year's Day, Memorial Day, Independence Day, Labor Day, Thanksgiving Day, the Friday after Thanksgiving Day, And Christmas Day (7). Any holiday which falls on a Sunday shall be observed as a holiday on the following Monday. When Christmas falls on a Saturday, the preceding Friday shall be observed as a holiday.
- P. Holidays: New Year's Day, Memorial Day, Independence Day, Labor Day, Thanksgiving Day, Friday after Thanksgiving Day, And Christmas Day (7). Any holiday which falls on a Sunday shall be observed as a holiday on the following Monday.
- Q. Holidays: New Year's Day, Memorial Day, Independence Day, Labor Day, Thanksgiving Day, the Friday after Thanksgiving Day, the Last Working Day before Christmas Day and Christmas Day (8). Any holiday which falls on a Sunday shall be observed as a holiday on the following Monday. If any of the listed holidays falls on a Saturday, the preceding Friday shall be a regular work day.
- S. Paid Holidays: New Year's Day, Memorial Day, Independence Day, Labor Day, Thanksgiving Day, Friday after Thanksgiving Day, Christmas Day, the Day after Christmas, and A Floating Holiday (9). If any of the listed holidays falls on a Sunday, the day observed by the Nation shall be considered a holiday and compensated accordingly.
- V. Holidays: New Year's Day, President's Birthday, Memorial Day, Independence Day, Labor Day, Thanksgiving Day, the Friday after Thanksgiving Day, Christmas Day, the day before or after Christmas, and the day before or after New Year's Day. If any of the above listed holidays falls on a Sunday, the day observed by the Nation shall be considered a holiday and compensated accordingly.
- W. Holidays: New Year's Day, Day After New Year's, Memorial Day, Independence Day, Labor Day, Thanksgiving Day, the Friday after Thanksgiving Day, Christmas Eve Day, Christmas Day, the day after Christmas, the day before New Year's Day, and a Floating Holiday.
- X. Holidays: New Year's Day, Day before or after New Year's Day, Presidents' Day, Memorial Day, Independence Day, Labor Day, Thanksgiving Day, the Friday after Thanksgiving Day, Christmas Day, and the day before or after Christmas day. If a holiday falls on a Saturday or on a Friday that is the normal day off, then the holiday will be taken on the last normal workday. If the holiday falls on a Monday that is the normal day off or on a Sunday, then the holiday will be taken on the next normal workday.
- Y. Holidays: New Year's Day, Presidents' Day, Memorial Day, Independence Day, Labor Day, Thanksgiving Day, the Friday after Thanksgiving Day, and Christmas Day. (8) If the holiday falls on a Sunday, then the day observed by the federal government shall be considered a holiday and compensated accordingly.
- Z. Holidays: New Year's Day, Memorial Day, Independence Day, Labor Day, Thanksgiving Day, the Friday and Saturday after Thanksgiving Day, Christmas Eve, and Christmas Day (9). Any holiday which falls on a Saturday shall be observed as a holiday on the preceding Friday. Any holiday which falls on a Sunday shall be observed as a holiday on the following Monday.

Holiday Codes Continued

15. G. New Year's Day, Washington's Birthday, Memorial Day, Independence Day, Labor Day, Thanksgiving Day, The Friday After Thanksgiving Day, the last scheduled workday before Christmas, and Christmas Day (9). If any of the listed holidays falls on a Sunday, the day observed by the Nation shall be considered a holiday and compensated accordingly.
- H. Holidays: New Year's Day, Martin Luther King Jr. Day, Independence Day, Memorial Day, Labor Day, Thanksgiving Day, the Friday after Thanksgiving Day, the Last Working Day before Christmas Day and Christmas Day (9). Any holiday which falls on a Sunday shall be observed as a holiday on the following Monday. Any holiday which falls on a Saturday shall be observed as a holiday on the preceding Friday.
- I. Holidays: New Year's Day, President's Day, Independence Day, Memorial Day, Labor Day, Thanksgiving Day, The Friday After Thanksgiving Day, The Day Before Christmas Day And Christmas Day (9). Any holiday which falls on a Sunday shall be observed as a holiday on the following Monday. Any holiday which falls on a Saturday shall be observed as a holiday on the preceding Friday.
- J. Holidays: New Year's Day, Martin Luther King Jr. Day, Memorial Day, Independence Day, Labor Day, Thanksgiving Day, the Friday and Saturday after Thanksgiving Day, and Christmas Day (9). Any holiday which falls on a Sunday shall be observed as a holiday on the following Monday. If any of the listed holidays falls on a Saturday, the preceding Friday shall be a regular work day.
- K. Holidays: New Year's Day, Memorial Day, Independence Day, Thanksgiving Day, the Friday and Saturday after Thanksgiving Day, And Christmas Day (8). Any holiday which falls on a Sunday shall be observed as a holiday on the following Monday. Any holiday which falls on a Saturday shall be observed as a holiday on the preceding Friday.
- L. Holidays: New Year's Day, Memorial Day, Independence Day, Labor Day, Veteran's Day, Thanksgiving Day, the Friday after Thanksgiving Day, and Christmas Day (8). Any holiday which falls on a Sunday shall be observed as a holiday on the following Monday. If any of the listed holidays falls on a Saturday, the preceding Friday shall be a regular work day.
- M. Holidays: New Year's Day, Martin Luther King Jr. Day, Independence Day, Memorial Day, Labor Day, Thanksgiving Day, the Friday after Thanksgiving Day, Christmas Eve Day and Christmas Day (9). Any holiday which falls on a Sunday shall be observed as a holiday on the following Monday. If any of the listed holidays falls on a Saturday, the preceding Friday shall be a regular work day.
- N. Holidays: New Year's Day, Memorial Day, Independence Day, Labor Day, Veteran's Day, Thanksgiving Day, the Friday after Thanksgiving Day, and Christmas Day (8). Any holiday which falls on a Sunday shall be observed as a holiday on the following Monday.

Note Codes

8. D. Workers working with supplied air on hazmat projects receive an additional \$1.00 per hour.
- L. Workers on hazmat projects receive additional hourly premiums as follows -Level A: \$0.75, Level B: \$0.50, And Level C: \$0.25.
- M. Workers on hazmat projects receive additional hourly premiums as follows: Levels A & B: \$1.00, Levels C & D: \$0.50.
- N. Workers on hazmat projects receive additional hourly premiums as follows -Level A: \$1.00, Level B: \$0.75, Level C: \$0.50, And Level D: \$0.25.

Note Codes Continued

8. S. Effective August 31, 2012 – A Traffic Control Supervisor shall be present on the project whenever flagging or spotting or other traffic control labor is being utilized. Flaggers and Spotters shall be posted where shown on approved Traffic Control Plans or where directed by the Engineer. All flaggers and spotters shall possess a current flagging card issued by the State of Washington, Oregon, Montana, or Idaho. This classification is only effective on or after August 31, 2012.
- T. Effective August 31, 2012 – A Traffic Control Laborer performs the setup, maintenance and removal of all temporary traffic control devices and construction signs necessary to control vehicular, bicycle, and pedestrian traffic during construction operations. Flaggers and Spotters shall be posted where shown on approved Traffic Control Plans or where directed by the Engineer. All flaggers and spotters shall possess a current flagging card issued by the State of Washington, Oregon, Montana, or Idaho. This classification is only effective on or after August 31, 2012.
- U. Workers on hazmat projects receive additional hourly premiums as follows – Class A Suit: \$2.00, Class B Suit: \$1.50, And Class C Suit: \$1.00. Workers performing underground work receive an additional \$0.40 per hour for any and all work performed underground, including operating, servicing and repairing of equipment. The premium for underground work shall be paid for the entire shift worked. Workers who work suspended by a rope or cable receive an additional \$0.50 per hour. The premium for work suspended shall be paid for the entire shift worked. Workers who do “pioneer” work (break open a cut, build road, etc.) more than one hundred fifty (150) feet above grade elevation receive an additional \$0.50 per hour.
- V. In addition to the hourly wage and fringe benefits, the following depth and enclosure premiums shall be paid. The premiums are to be calculated for the maximum depth and distance into an enclosure that a diver reaches in a day. The premiums are to be paid one time for the day and are not used in calculating overtime pay.
- Depth premiums apply to depths of fifty feet or more. Over 50' to 100' - \$2.00 per foot for each foot over 50 feet. Over 101' to 150' - \$3.00 per foot for each foot over 101 feet. Over 151' to 220' - \$4.00 per foot for each foot over 220 feet. Over 221' - \$5.00 per foot for each foot over 221 feet.
- Enclosure premiums apply when divers enter enclosures (such as pipes or tunnels) where there is no vertical ascent and is measured by the distance travelled from the entrance. 25' to 300' - \$1.00 per foot from entrance. 300' to 600' - \$1.50 per foot beginning at 300'. Over 600' - \$2.00 per foot beginning at 600'.
- W. Meter Installers work on single phase 120/240V self-contained residential meters. The Lineman/Groundmen rates would apply to meters not fitting this description.
- X. Workers on hazmat projects receive additional hourly premiums as follows - Class A Suit: \$2.00, Class B Suit: \$1.50, Class C Suit: \$1.00, and Class D Suit: \$0.50. Special Shift Premium: Basic hourly rate plus \$2.00 per hour.
- When due to conditions beyond the control of the Employer or when an owner (not acting as the contractor), a government agency or the contract specifications requires that work can only be performed outside the normal 5 am to 6pm shift, then the special shift premium will be applied to the basic hourly rate. When an employee works on a special shift, they shall be paid a special shift premium for each hour worked unless they are in OT or Double-time status. (For example, the special shift premium does not waive the overtime requirements for work performed on Saturday or Sunday.)
- Y. Tide Work: When employees are called out between the hours of 6:00 p.m. and 6:00 a.m. to work on tide work (work located in the tide plane) all time worked shall be at one and one-half times the hourly rate of pay.
- Swinging Stage/Boatswains Chair: Employees working on a swinging state or boatswains chair or under conditions that require them to be tied off to allow their hands to be free shall receive seventy-five cents (\$0.75) per hour above the classification rate.

Note Codes Continued

8. Z. Workers working with supplied air on hazmat projects receive an additional \$1.00 per hour.

Special Shift Premium: Basic hourly rate plus \$2.00 per hour. When due to conditions beyond the control of the Employer or when an owner (not acting as a contractor), a government agency or the contract specifications require that more than (4) hours of a special shift can only be performed outside the normal 6 am to 6pm shift, then the special shift premium will be applied to the basic straight time for the entire shift. When an employee works on a special shift, they will be paid a special shift premium for each hour worked unless they are in overtime or double-time status. (For example, the special shift premium does not waive the overtime requirements for work performed on Saturday or Sunday.)

9. A. Workers working with supplied air on hazmat projects receive an additional \$1.00 per hour.

Special Shift Premium: Basic hourly rate plus \$2.00 per hour. When due to conditions beyond the control of the Employer or when an owner (not acting as the contractor), a government agency or the contract specifications require that more than four (4) hours of a special shift can only be performed outside the normal 6 am to 6pm shift, then the special shift premium will be applied to the basic straight time for the entire shift. When an employee works on a special shift, they shall be paid a special shift premium for each hour worked unless they are in overtime or double-time status. (For example, the special shift premium does not waive the overtime requirements for work performed on Saturday or Sunday.)

Certified Crane Operator Premium: Crane operators requiring certifications shall be paid \$0.50 per hour above their classification rate.

Boom Pay Premium: All cranes including tower shall be paid as follows based on boom length:

(A) – 130' to 199' – \$0.50 per hour over their classification rate.

(B) – 200' to 299' – \$0.80 per hour over their classification rate.

(C) – 300' and over – \$1.00 per hour over their classification rate.

- B. The highest pressure registered on the gauge for an accumulated time of more than fifteen (15) minutes during the shift shall be used in determining the scale paid.

Tide Work: When employees are called out between the hours of 6:00 p.m. and 6:00 a.m. to work on tide work (work located in the tide plane) all time worked shall be at one and one-half times the hourly rate of pay. Swinging Stage/Boatswains Chair: Employees working on a swinging stage or boatswains chair or under conditions that require them to be tied off to allow their hands to be free shall receive seventy-five cents (\$0.75) per hour above the classification rate.

- C. Tide Work: When employees are called out between the hours of 6:00 p.m. and 6:00 a.m. to work on tide work (work located in the tide plane) all time worked shall be at one and one-half times the hourly rate of pay. Swinging Stage/Boatswains Chair: Employees working on a swinging stage or boatswains chair or under conditions that require them to be tied off to allow their hands to be free shall receive seventy-five cents (\$0.75) per hour above the classification rate.

Effective August 31, 2012 – A Traffic Control Supervisor shall be present on the project whenever flagging or spotting or other traffic control labor is being utilized. A Traffic Control Laborer performs the setup, maintenance and removal of all temporary traffic control devices and construction signs necessary to control vehicular, bicycle, and pedestrian traffic during construction operations. Flaggers and Spotters shall be posted where shown on approved Traffic Control Plans or where directed by the Engineer. All flaggers and spotters shall possess a current flagging card issued by the State of Washington, Oregon, Montana, or Idaho. These classifications are only effective on or after August 31, 2012.

- D. Industrial Painter wages are required for painting within industrial facilities such as treatment plants, pipelines, towers, dams, bridges, power generation facilities and manufacturing facilities such as chemical plants, etc., or anywhere abrasive blasting is necessary to prepare surfaces, or hazardous materials encapsulation is required.

Note Codes Continued

- 9. E. Heavy Construction includes construction, repair, alteration or additions to the production, fabrication or manufacturing portions of industrial or manufacturing plants, hydroelectric or nuclear power plants and atomic reactor construction. Workers on hazmat projects receive additional hourly premiums as follows -Level A: \$1.00, Level B: \$0.75, Level C: \$0.50, And Level D: \$0.25.
- F. Industrial Painter wages are required for painting within industrial facilities such as treatment plants, pipelines, towers, dams, power generation facilities and manufacturing facilities such as chemical plants, etc., or anywhere abrasive blasting is necessary to prepare surfaces, or hazardous materials encapsulation is required.
- H. One (1) person crew shall consist of a Party Chief. (Total Station or similar one (1) person survey system). Two (2) person survey party shall consist of a least a Party Chief and a Chain Person. Three (3) person survey party shall consist of at least a Party Chief, an Instrument Person, and a Chain Person.

Washington State Department of Labor and Industries
Policy Statement
(Regarding the Production of "Standard" or "Non-standard" Items)

Below is the department's (State L&I's) list of criteria to be used in determining whether a prefabricated item is "standard" or "non-standard". For items not appearing on WSDOT's predetermined list, these criteria shall be used by the Contractor (and the Contractor's subcontractors, agents to subcontractors, suppliers, manufacturers, and fabricators) to determine coverage under RCW 39.12. The production, in the State of Washington, of non-standard items is covered by RCW 39.12, and the production of standard items is not. The production of any item outside the State of Washington is not covered by RCW 39.12.

1. Is the item fabricated for a public works project? If not, it is not subject to RCW 39.12. If it is, go to question 2.
2. Is the item fabricated on the public works jobsite? If it is, the work is covered under RCW 39.12. If not, go to question 3.
3. Is the item fabricated in an assembly/fabrication plant set up for, and dedicated primarily to, the public works project? If it is, the work is covered by RCW 39.12. If not, go to question 4.
4. Does the item require any assembly, cutting, modification or other fabrication by the supplier? If not, the work is not covered by RCW 39.12. If yes, go to question 5.
5. Is the prefabricated item intended for the public works project typically an inventory item which could reasonably be sold on the general market? If not, the work is covered by RCW 39.12. If yes, go to question 6.
6. Does the specific prefabricated item, generally defined as standard, have any unusual characteristics such as shape, type of material, strength requirements, finish, etc? If yes, the work is covered under RCW 39.12.

Any firm with questions regarding the policy, WSDOT's Predetermined List, or for determinations of covered and non-covered workers shall be directed to State L&I at (360) 902-5330.

**WSDOT's
Predetermined List for
Suppliers - Manufactures - Fabricator**

Below is a list of potentially prefabricated items, originally furnished by WSDOT to Washington State Department of Labor and Industries, that may be considered non-standard and therefore covered by the prevailing wage law, RCW 39.12. Items marked with an X in the "YES" column should be considered to be non-standard and therefore covered by RCW 39.12. Items marked with an X in the "NO" column should be considered to be standard and therefore not covered. Of course, exceptions to this general list may occur, and in that case shall be evaluated according to the criteria described in State and L&I's policy statement.

ITEM DESCRIPTION	YES	NO
1. Metal rectangular frames, solid metal covers, herringbone grates, and bi-directional vaned grates for Catch Basin Types 1, 1L, 1P, and 2 and Concrete Inlets. See Std. Plans		X
2. Metal circular frames (rings) and covers, circular grates, and prefabricated ladders for Manhole Types 1, 2, and 3, Drywell Types 1, 2, and 3 and Catch Basin Type 2. See Std. Plans		X
3. Prefabricated steel grate supports and welded grates, metal frames and dual vaned grates, and Type 1, 2, and 3 structural tubing grates for Drop Inlets. See Std. Plans.		X
4. Concrete Pipe - Plain Concrete pipe and reinforced concrete pipe Class 2 to 5 sizes smaller than 60 inch diameter.		X
5. Concrete Pipe - Plain Concrete pipe and reinforced concrete pipe Class 2 to 5 sizes larger than 60 inch diameter.		X
6. Corrugated Steel Pipe - Steel lock seam corrugated pipe for culverts and storm sewers, sizes 30 inch to 120 inches in diameter. May also be treated, 1 thru 5.		X
7. Corrugated Aluminum Pipe - Aluminum lock seam corrugated pipe for culverts and storm sewers, sizes 30 inch to 120 inches in diameter. May also be treated, #5.		X

ITEM DESCRIPTION	YES	NO
8. Anchor Bolts & Nuts - Anchor Bolts and Nuts, for mounting sign structures, luminaries and other items, shall be made from commercial bolt stock. See Contract Plans and Std. Plans for size and material type.		X
9. Aluminum Pedestrian Handrail - Pedestrian handrail conforming to the type and material specifications set forth in the contract plans. Welding of aluminum shall be in accordance with Section 9-28.14(3).	X	
10. Major Structural Steel Fabrication - Fabrication of major steel items such as trusses, beams, girders, etc., for bridges.	X	
11. Minor Structural Steel Fabrication - Fabrication of minor steel Items such as special hangers, brackets, access doors for structures, access ladders for irrigation boxes, bridge expansion joint systems, etc., involving welding, cutting, punching and/or boring of holes. See Contact Plans for item description and shop drawings.	X	
12. Aluminum Bridge Railing Type BP - Metal bridge railing conforming to the type and material specifications set forth in the Contract Plans. Welding of aluminum shall be in accordance with Section 9-28.14(3).		X
13. Concrete Piling--Precast-Prestressed concrete piling for use as 55 and 70 ton concrete piling. Concrete to conform to Section 9-19.1 of Std. Spec..	X	
14. Precast Manhole Types 1, 2, and 3 with cones, adjustment sections and flat top slabs. See Std. Plans.		X
15. Precast Drywell Types 1, 2, and with cones and adjustment Sections. See Std. Plans.		X
16. Precast Catch Basin - Catch Basin type 1, 1L, 1P, and 2 With adjustment sections. See Std. Plans.		X

ITEM DESCRIPTION	YES	NO
17. Precast Concrete Inlet - with adjustment sections, See Std. Plans		X
18. Precast Drop Inlet Type 1 and 2 with metal grate supports. See Std. Plans.		X
19. Precast Grate Inlet Type 2 with extension and top units. See Std. Plans		X
20. Metal frames, vaned grates, and hoods for Combination Inlets. See Std. Plans		X
21. Precast Concrete Utility Vaults - Precast Concrete utility vaults of various sizes. Used for in ground storage of utility facilities and controls. See Contract Plans for size and construction requirements. Shop drawings are to be provided for approval prior to casting		X
22. Vault Risers - For use with Valve Vaults and Utilities X Vaults.		X
23. Valve Vault - For use with underground utilities. See Contract Plans for details.		X
24. Precast Concrete Barrier - Precast Concrete Barrier for use as new barrier or may also be used as Temporary Concrete Barrier. Only new state approved barrier may be used as permanent barrier.		X
25. Reinforced Earth Wall Panels – Reinforced Earth Wall Panels in size and shape as shown in the Plans. Fabrication plant has annual approval for methods and materials to be used. See Shop Drawing. Fabrication at other locations may be approved, after facilities inspection, contact HQ. Lab.	X	
26. Precast Concrete Walls - Precast Concrete Walls - tilt-up wall panel in size and shape as shown in Plans. Fabrication plant has annual approval for methods and materials to be used	X	

ITEM DESCRIPTION	YES	NO
27. Precast Railroad Crossings - Concrete Crossing Structure Slabs.	X	
28. 12, 18 and 26 inch Standard Precast Prestressed Girder – Standard Precast Prestressed Girder for use in structures. Fabricator plant has annual approval of methods and materials to be used. Shop Drawing to be provided for approval prior to casting girders. See Std. Spec. Section 6-02.3(25)A	X	
29. Prestressed Concrete Girder Series 4-14 - Prestressed Concrete Girders for use in structures. Fabricator plant has annual approval of methods and materials to be used. Shop Drawing to be provided for approval prior to casting girders. See Std. Spec. Section 6-02.3(25)A	X	
30. Prestressed Tri-Beam Girder - Prestressed Tri-Beam Girders for use in structures. Fabricator plant has annual approval of methods and materials to be used. Shop Drawing to be provided for approval prior to casting girders. See Std. Spec. Section 6-02.3(25)A	X	
31. Prestressed Precast Hollow-Core Slab – Precast Prestressed Hollow-core slab for use in structures. Fabricator plant has annual approval of methods and materials to be used. Shop Drawing to be provided for approval prior to casting girders. See Std. Spec. Section 6-02.3(25)A.	X	
32. Prestressed-Bulb Tee Girder - Bulb Tee Prestressed Girder for use in structures. Fabricator plant has annual approval of methods and materials to be used. Shop Drawing to be provided for approval prior to casting girders. See Std. Spec. Section 6-02.3(25)A	X	
33. Monument Case and Cover See Std. Plan.		X

ITEM DESCRIPTION	YES	NO
34. Cantilever Sign Structure - Cantilever Sign Structure fabricated from steel tubing meeting AASHTO-M-183. See Std. Plans, and Contract Plans for details. The steel structure shall be galvanized after fabrication in accordance with AASHTO-M-111.	X	
35. Mono-tube Sign Structures - Mono-tube Sign Bridge fabricated to details shown in the Plans. Shop drawings for approval are required prior to fabrication.	X	
36. Steel Sign Bridges - Steel Sign Bridges fabricated from steel tubing meeting AASHTO-M-138 for Aluminum Alloys. See Std. Plans, and Contract Plans for details. The steel structure shall be galvanized after fabrication in accordance with AASHTO-M-111.	X	
37. Steel Sign Post - Fabricated Steel Sign Posts as detailed in Std Plans. Shop drawings for approval are to be provided prior to fabrication		X
38. Light Standard-Prestressed - Spun, prestressed, hollow concrete poles.	X	
39. Light Standards - Lighting Standards for use on highway illumination systems, poles to be fabricated to conform with methods and materials as specified on Std. Plans. See Special Provisions for pre-approved drawings.	X	
40. Traffic Signal Standards - Traffic Signal Standards for use on highway and/or street signal systems. Standards to be fabricated to conform with methods and material as specified on Std. Plans. See Special Provisions for pre-approved drawings	X	
41. Precast Concrete Sloped Mountable Curb (Single and DualFaced) See Std. Plans.		X

ITEM DESCRIPTION	YES	NO
42. Traffic Signs - Prior to approval of a Fabricator of Traffic Signs, the sources of the following materials must be submitted and approved for reflective sheeting, legend material, and aluminum sheeting. NOTE: *** Fabrication inspection required. Only signs tagged "Fabrication Approved" by WSDOT Sign Fabrication Inspector to be installed	X	X
	Custom Message	Std Signing Message
43. Cutting & bending reinforcing steel		X
44. Guardrail components	X	X
	Custom End Sec	Standard Sec
45. Aggregates/Concrete mixes	Covered by WAC 296-127-018	
46. Asphalt	Covered by WAC 296-127-018	
47. Fiber fabrics		X
48. Electrical wiring/components		X
49. treated or untreated timber pile		X
50. Girder pads (elastomeric bearing)	X	
51. Standard Dimension lumber		X
52. Irrigation components		X

ITEM DESCRIPTION	YES	NO
53. Fencing materials		X
54. Guide Posts		X
55. Traffic Buttons		X
56. Epoxy		X
57. Cribbing		X
58. Water distribution materials		X
59. Steel "H" piles		X
60. Steel pipe for concrete pile casings		X
61. Steel pile tips, standard		X
62. Steel pile tips, custom	X	

Prefabricated items specifically produced for public works projects that are prefabricated in a county other than the county wherein the public works project is to be completed, the wage for the offsite prefabrication shall be the applicable prevailing wage for the county in which the actual prefabrication takes place.

It is the manufacturer of the prefabricated product to verify that the correct county wage rates are applied to work they perform.

See RCW [39.12.010](#)

(The definition of "locality" in RCW [39.12.010](#)(2) contains the phrase "wherein the physical work is being performed." The department interprets this phrase to mean the actual work site.

WSDOT's List of State Occupations not applicable to Heavy and Highway Construction Projects

This project is subject to the state hourly minimum rates for wages and fringe benefits in the contract provisions, as provided by the state Department of Labor and Industries.

The following list of occupations, is comprised of those occupations that are not normally used in the construction of heavy and highway projects.

When considering job classifications for use and / or payment when bidding on, or building heavy and highway construction projects for, or administered by WSDOT, these Occupations will be excepted from the included "Washington State Prevailing Wage Rates For Public Work Contracts" documents.

- Building Service Employees
- Electrical Fixture Maintenance Workers
- Electricians - Motor Shop
- Heating Equipment Mechanics
- Industrial Engine and Machine Mechanics
- Industrial Power Vacuum Cleaners
- Inspection, Cleaning, Sealing of Water Systems by Remote Control
- Laborers - Underground Sewer & Water
- Machinists (Hydroelectric Site Work)
- Modular Buildings
- Playground & Park Equipment Installers
- Power Equipment Operators - Underground Sewer & Water
- Residential *** ALL ASSOCIATED RATES ***
- Sign Makers and Installers (Non-Electrical)
- Sign Makers and Installers (Electrical)
- Stage Rigging Mechanics (Non Structural)

The following occupations may be used only as outlined in the preceding text concerning "WSDOT's list for Suppliers - Manufacturers - Fabricators"

- Fabricated Precast Concrete Products
- Metal Fabrication (In Shop)

Definitions for the Scope of Work for prevailing wages may be found at the Washington State Department of Labor and Industries web site and in WAC Chapter 296-127.

Washington State Department of Labor and Industries
Policy Statements
(Regarding Production and Delivery of Gravel, Concrete, Asphalt, etc.)

WAC 296-127-018 Agency filings affecting this section

Coverage and exemptions of workers involved in the production and delivery of gravel, concrete, asphalt, or similar materials.

(1) The materials covered under this section include but are not limited to: Sand, gravel, crushed rock, concrete, asphalt, or other similar materials.

(2) All workers, regardless of by whom employed, are subject to the provisions of chapter 39.12 RCW when they perform any or all of the following functions:

(a) They deliver or discharge any of the above-listed materials to a public works project site:

(i) At one or more point(s) directly upon the location where the material will be incorporated into the project; or

(ii) At multiple points at the project; or

(iii) Adjacent to the location and coordinated with the incorporation of those materials.

(b) They wait at or near a public works project site to perform any tasks subject to this section of the rule.

(c) They remove any materials from a public works construction site pursuant to contract requirements or specifications (e.g., excavated materials, materials from demolished structures, clean-up materials, etc.).

(d) They work in a materials production facility (e.g., batch plant, borrow pit, rock quarry, etc.) which is established for a public works project for the specific, but not necessarily exclusive, purpose of supplying materials for the project.

(e) They deliver concrete to a public works site regardless of the method of incorporation.

(f) They assist or participate in the incorporation of any materials into the public works project.

(3) All travel time that relates to the work covered under subsection (2) of this section requires the payment of prevailing wages. Travel time includes time spent waiting to load, loading, transporting, waiting to unload, and delivering materials. Travel time would include all time spent in travel in support of a public works project whether the vehicle is empty or full. For example, travel time spent returning to a supply source to obtain another load of material for use on a public works site or returning to the public works site to obtain another load of excavated material is time spent in travel that is subject to prevailing wage. Travel to a supply source, including travel from a public works site, to obtain materials for use on a private project would not be travel subject to the prevailing wage.

(4) Workers are not subject to the provisions of chapter 39.12 RCW when they deliver materials to a stockpile.

(a) A "stockpile" is defined as materials delivered to a pile located away from the site of incorporation such that the stockpiled materials must be physically moved from the stockpile and transported to another location on the project site in order to be incorporated into the project.

(b) A stockpile does not include any of the functions described in subsection (2)(a) through (f) of this section; nor does a stockpile include materials delivered or distributed to multiple locations upon the project site; nor does a stockpile include materials dumped at the place of incorporation, or adjacent to the location and coordinated with the incorporation.

(5) The applicable prevailing wage rate shall be determined by the locality in which the work is performed. Workers subject to subsection (2)(d) of this section, who produce such materials at an off-site facility shall be paid the applicable prevailing wage rates for the county in which the off-site facility is located. Workers subject to subsection (2) of this section, who deliver such materials to a public works project site shall be paid the applicable prevailing wage rates for the county in which the public works project is located.

[Statutory Authority: Chapter 39.12 RCW, RCW 43.22.051 and 43.22.270. 08-24-101, § 296-127-018, filed 12/2/08, effective 1/2/09. Statutory Authority: Chapters 39.04 and 39.12 RCW and RCW 43.22.270. 92-01-104 and 92-08-101, § 296-127-018, filed 12/18/91 and 4/1/92, effective 8/31/92.]

PREVAILING WAGES

8/31/2023

County	Trade	Job Classification	Wage	Holiday	Overtime	Notes
King	Flaggers	Journey Level	\$50.07	15J	4V	8Y
King	Laborers	Air, Gas Or Electric Vibrating Screed	\$59.07	15J	4V	8Y
King	Laborers	Airtrac Drill Operator	\$60.90	15J	4V	8Y
King	Laborers	Ballast Regular Machine	\$59.07	15J	4V	8Y
King	Laborers	Batch Weighman	\$50.07	15J	4V	8Y
King	Laborers	Brick Pavers	\$59.07	15J	4V	8Y
King	Laborers	Brush Cutter	\$59.07	15J	4V	8Y
King	Laborers	Brush Hog Feeder	\$59.07	15J	4V	8Y
King	Laborers	Burner	\$59.07	15J	4V	8Y
King	Laborers	Caisson Worker	\$60.90	15J	4V	8Y
King	Laborers	Carpenter Tender	\$59.07	15J	4V	8Y
King	Laborers	Cement Dumper-paving	\$60.15	15J	4V	8Y
King	Laborers	Cement Finisher Tender	\$59.07	15J	4V	8Y
King	Laborers	Change House Or Dry Shack	\$59.07	15J	4V	8Y
King	Laborers	Chipping Gun (30 Lbs. And Over)	\$60.15	15J	4V	8Y
King	Laborers	Chipping Gun (Under 30 Lbs.)	\$59.07	15J	4V	8Y
King	Laborers	Choker Setter	\$59.07	15J	4V	8Y
King	Laborers	Chuck Tender	\$59.07	15J	4V	8Y
King	Laborers	Clary Power Spreader	\$60.15	15J	4V	8Y
King	Laborers	Clean-up Laborer	\$59.07	15J	4V	8Y
King	Laborers	Concrete Dumper/Chute Operator	\$60.15	15J	4V	8Y
King	Laborers	Concrete Form Stripper	\$59.07	15J	4V	8Y
King	Laborers	Concrete Placement Crew	\$60.15	15J	4V	8Y
King	Laborers	Concrete Saw Operator/Core Driller	\$60.15	15J	4V	8Y
King	Laborers	Crusher Feeder	\$50.07	15J	4V	8Y
King	Laborers	Curing Laborer	\$59.07	15J	4V	8Y
King	Laborers	Demolition: Wrecking & Moving (Incl. Charred Material)	\$59.07	15J	4V	8Y
King	Laborers	Ditch Digger	\$59.07	15J	4V	8Y
King	Laborers	Diver	\$60.90	15J	4V	8Y
King	Laborers	Drill Operator (Hydraulic, Diamond)	\$60.15	15J	4V	8Y
King	Laborers	Dry Stack Walls	\$59.07	15J	4V	8Y
King	Laborers	Dump Person	\$59.07	15J	4V	8Y
King	Laborers	Epoxy Technician	\$59.07	15J	4V	8Y
King	Laborers	Erosion Control Worker	\$59.07	15J	4V	8Y
King	Laborers	Faller & Bucker Chain Saw	\$60.15	15J	4V	8Y
King	Laborers	Fine Graders	\$59.07	15J	4V	8Y
King	Laborers	Firewatch	\$50.07	15J	4V	8Y
King	Laborers	Form Setter	\$60.15	15J	4V	8Y
King	Laborers	Gabian Basket Builders	\$59.07	15J	4V	8Y
King	Laborers	General Laborer	\$59.07	15J	4V	8Y
King	Laborers	Grade Checker & Transit Person	\$62.49	15J	4V	8Y
King	Laborers	Grinders	\$59.07	15J	4V	8Y
King	Laborers	Grout Machine Tender	\$59.07	15J	4V	8Y
King	Laborers	Groutmen (Pressure) Including Post Tension Beams	\$60.15	15J	4V	8Y
King	Laborers	Guardrail Erector	\$59.07	15J	4V	8Y
King	Laborers	Hazardous Waste Worker (Level A)	\$60.90	15J	4V	8Y
King	Laborers	Hazardous Waste Worker (Level B)	\$60.15	15J	4V	8Y
King	Laborers	Hazardous Waste Worker (Level C)	\$59.07	15J	4V	8Y
King	Laborers	High Scaler	\$60.90	15J	4V	8Y
King	Laborers	Jackhammer	\$60.15	15J	4V	8Y
King	Laborers	Laserbeam Operator	\$60.15	15J	4V	8Y
King	Laborers	Maintenance Person	\$59.07	15J	4V	8Y
King	Laborers	Manhole Builder-Mudman	\$60.15	15J	4V	8Y
King	Laborers	Material Yard Person	\$59.07	15J	4V	8Y
King	Laborers	Mold Abatement Worker	\$59.07	15J	4V	8Y
King	Laborers	Motorman-Dinky Locomotive	\$62.59	15J	4V	8Y
King	Laborers	nozzleman (concrete pump, green cutter when using combination of high pressure air & water on concrete & rock, sandblast, gunite, shotcrete, water blaster, vacuum blaster)	\$62.49	15J	4V	8Y
King	Laborers	Pavement Breaker	\$60.15	15J	4V	8Y
King	Laborers	Pilot Car	\$50.07	15J	4V	8Y
King	Laborers	Pipe Layer (Lead)	\$62.49	15J	4V	8Y
King	Laborers	Pipe Layer/Tailor	\$60.15	15J	4V	8Y
King	Laborers	Pipe Pot Tender	\$60.15	15J	4V	8Y
King	Laborers	Pipe Reliner	\$60.15	15J	4V	8Y

PREVAILING WAGES

8/31/2023

County	Trade	Job Classification	Wage	Holiday	Overtime	Notes
King	Laborers	Pipe Wrapper	\$60.15	15J	4V	8Y
King	Laborers	Pot Tender	\$59.07	15J	4V	8Y
King	Laborers	Powderman	\$60.90	15J	4V	8Y
King	Laborers	Powderman's Helper	\$59.07	15J	4V	8Y
King	Laborers	Power Jacks	\$60.15	15J	4V	8Y
King	Laborers	Railroad Spike Puller - Power	\$60.15	15J	4V	8Y
King	Laborers	Raker - Asphalt	\$62.49	15J	4V	8Y
King	Laborers	Re-timberman	\$60.90	15J	4V	8Y
King	Laborers	Remote Equipment Operator	\$60.15	15J	4V	8Y
King	Laborers	Rigger/Signal Person	\$60.15	15J	4V	8Y
King	Laborers	Rip Rap Person	\$59.07	15J	4V	8Y
King	Laborers	Rivet Buster	\$60.15	15J	4V	8Y
King	Laborers	Rodder	\$60.15	15J	4V	8Y
King	Laborers	Scaffold Erector	\$59.07	15J	4V	8Y
King	Laborers	Scale Person	\$59.07	15J	4V	8Y
King	Laborers	Sloper (Over 20")	\$60.15	15J	4V	8Y
King	Laborers	Sloper Sprayer	\$59.07	15J	4V	8Y
King	Laborers	Spreader (Concrete)	\$60.15	15J	4V	8Y
King	Laborers	Stake Hopper	\$59.07	15J	4V	8Y
King	Laborers	Stock Piler	\$59.07	15J	4V	8Y
King	Laborers	Swinging Stage/Boatswain Chair	\$50.07	15J	4V	8Y
King	Laborers	Tamper & Similar Electric, Air & Gas Operated Tools	\$60.15	15J	4V	8Y
King	Laborers	Tamper (Multiple & Self-propelled)	\$60.15	15J	4V	8Y
King	Laborers	Timber Person - Sewer (Lagger, Shorer & Cribber)	\$60.15	15J	4V	8Y
King	Laborers	Toolroom Person (at Jobsite)	\$59.07	15J	4V	8Y
King	Laborers	Topper	\$59.07	15J	4V	8Y
King	Laborers	Track Laborer	\$59.07	15J	4V	8Y
King	Laborers	Track Liner (Power)	\$60.15	15J	4V	8Y
King	Laborers	Traffic Control Laborer	\$53.54	15J	4V	9C
King	Laborers	Traffic Control Supervisor	\$56.73	15J	4V	9C
King	Laborers	Truck Spotter	\$59.07	15J	4V	8Y
King	Laborers	Tugger Operator	\$60.15	15J	4V	8Y
King	Laborers	Tunnel Work-Compressed Air Worker 0-30 psi	\$175.79	15J	4V	9B
King	Laborers	Tunnel Work-Compressed Air Worker 30.01-44.00 psi	\$180.82	15J	4V	9B
King	Laborers	Tunnel Work-Compressed Air Worker 44.01-54.00 psi	\$184.50	15J	4V	9B
King	Laborers	Tunnel Work-Compressed Air Worker 54.01-60.00 psi	\$190.20	15J	4V	9B
King	Laborers	Tunnel Work-Compressed Air Worker 60.01-64.00 psi	\$192.32	15J	4V	9B
King	Laborers	Tunnel Work-Compressed Air Worker 64.01-68.00 psi	\$197.42	15J	4V	9B
King	Laborers	Tunnel Work-Compressed Air Worker 68.01-70.00 psi	\$199.32	15J	4V	9B
King	Laborers	Tunnel Work-Compressed Air Worker 70.01-72.00 psi	\$201.32	15J	4V	9B
King	Laborers	Tunnel Work-Compressed Air Worker 72.01-74.00 psi	\$203.32	15J	4V	9B
King	Laborers	Tunnel Work-Guage and Lock Tender	\$62.59	15J	4V	8Y
King	Laborers	Tunnel Work-Miner	\$62.59	15J	4V	8Y
King	Laborers	Vibrator	\$60.15	15J	4V	8Y
King	Laborers	Vinyl Seamer	\$59.07	15J	4V	8Y
King	Laborers	Watchman	\$45.51	15J	4V	8Y
King	Laborers	Welder	\$60.15	15J	4V	8Y
King	Laborers	Well Point Laborer	\$60.15	15J	4V	8Y
King	Laborers	Window Washer/Cleaner	\$45.51	15J	4V	8Y
King	Landscape Construction	Landscape Construction/Landscaping Or Planting Laborers	\$45.51	15J	4V	8Y
King	Landscape Construction	Landscape Operator	\$82.25	15J	11G	8X
King	Power Equipment Operators	Asphalt Plant Operators	\$83.62	15J	11G	8X
King	Power Equipment Operators	Assistant Engineer	\$78.65	15J	11G	8X
King	Power Equipment Operators	Barrier Machine (zipper)	\$82.88	15J	11G	8X
King	Power Equipment Operators	Batch Plant Operator: concrete	\$82.88	15J	11G	8X
King	Power Equipment Operators	Boat Operator	\$83.95	7A	11H	8X
King	Power Equipment Operators	Bobcat	\$78.65	15J	11G	8X
King	Power Equipment Operators	Brokk - Remote Demolition Equipment	\$78.65	15J	11G	8X
King	Power Equipment Operators	Brooms	\$78.65	15J	11G	8X
King	Power Equipment Operators	Bump Cutter	\$82.88	15J	11G	8X
King	Power Equipment Operators	Cableways	\$83.62	15J	11G	8X
King	Power Equipment Operators	Chipper	\$82.88	15J	11G	8X
King	Power Equipment Operators	Compressor	\$78.65	15J	11G	8X
King	Power Equipment Operators	Concrete Finish Machine - Laser Screed	\$78.65	15J	11G	8X
King	Power Equipment Operators	Concrete Pump - Mounted Or Trailer High Pressure Line Pump,				
King	Power Equipment Operators	Pump High Pressure	\$82.25	15J	11G	8X

PREVAILING WAGES

8/31/2023

County	Trade	Job Classification	Wage	Holiday	Overtime	Notes
King	Power Equipment Operators	Concrete Pump: Truck Mount With Boom Attachment Over 42 M	\$83.62	15J	11G	8X
King	Power Equipment Operators	Concrete Pump: Truck Mount With Boom Attachment Up To 42m	\$82.88	15J	11G	8X
King	Power Equipment Operators	Conveyors	\$82.25	15J	11G	8X
King	Power Equipment Operators	Cranes Friction: 200 tons and over	\$86.48	7A	11H	8X
King	Power Equipment Operators	Cranes, A-frame: 10 tons and under	\$78.95	7A	11H	8X
King	Power Equipment Operators	Cranes: 100 tons through 199 tons, or 150' of boom (including jib with attachments)	\$84.77	7A	11H	8X
King	Power Equipment Operators	Cranes: 20 tons through 44 tons with attachments	\$83.20	7A	11H	8X
King	Power Equipment Operators	Cranes: 200 tons- 299 tons, or 250' of boom including jib with attachments	\$85.66	7A	11H	8X
King	Power Equipment Operators	Cranes: 300 tons and over or 300' of boom including jib with attachments	\$86.48	7A	11H	8X
King	Power Equipment Operators	Cranes: 45 tons through 99 tons, under 150' of boom(including jib with attachments)	\$83.95	7A	11H	8X
King	Power Equipment Operators	Cranes: Friction cranes through 199 tons	\$85.66	7A	11H	8X
King	Power Equipment Operators	Cranes: through 19 tons with attachments, a-frame over 10 tons	\$82.56	7A	11H	8X
King	Power Equipment Operators	Crusher	\$82.88	15J	11G	8X
King	Power Equipment Operators	Deck Engineer/Deck Winches (power)	\$82.88	15J	11G	8X
King	Power Equipment Operators	Derricks, On Building Work	\$83.62	15J	11G	8X
King	Power Equipment Operators	Dozers D-9 & Under	\$82.25	15J	11G	8X
King	Power Equipment Operators	Drill Oilers: Auger Type, Truck Or Crane Mount	\$82.25	15J	11G	8X
King	Power Equipment Operators	Drilling Machine	\$84.46	15J	11G	8X
King	Power Equipment Operators	Elevator and man-lift: permanent and shaft type	\$78.65	15J	11G	8X
King	Power Equipment Operators	Finishing Machine, Bidwell And Gamaco & Similar Equipment	\$82.88	15J	11G	8X
King	Power Equipment Operators	Forklift: 3000 lbs and over with attachments	\$82.25	15J	11G	8X
King	Power Equipment Operators	Forklifts: under 3000 lbs. with attachments	\$78.65	15J	11G	8X
King	Power Equipment Operators	Grade Engineer: Using Blue Prints, Cut Sheets, Etc	\$82.88	15J	11G	8X
King	Power Equipment Operators	Gradechecker/Stakeman	\$78.65	15J	11G	8X
King	Power Equipment Operators	Guardrail Punch	\$82.88	15J	11G	8X
King	Power Equipment Operators	Hard Tail End Dump Articulating Off- Road Equipment 45 Yards. & Over	\$83.62	15J	11G	8X
King	Power Equipment Operators	Hard Tail End Dump Articulating Off-road Equipment Under 45 Yards	\$82.88	15J	11G	8X
King	Power Equipment Operators	Horizontal/Directional Drill Locator	\$82.25	15J	11G	8X
King	Power Equipment Operators	Horizontal/Directional Drill Operator	\$82.88	15J	11G	8X
King	Power Equipment Operators	Hydralifts/Boom Trucks Over 10 Tons	\$82.56	7A	11H	8X
King	Power Equipment Operators	Hydralifts/boom trucks: 10 tons and under	\$78.95	7A	11H	8X
King	Power Equipment Operators	Leverman	\$85.33	15J	11G	8X
King	Power Equipment Operators	Loader, Overhead, 6 Yards. But Not Including 8 Yards	\$83.62	15J	11G	8X
King	Power Equipment Operators	Loaders, Overhead Under 6 Yards	\$82.88	15J	11G	8X
King	Power Equipment Operators	Loaders, Plant Feed	\$82.88	15J	11G	8X
King	Power Equipment Operators	Loaders: Elevating Type Belt	\$82.25	15J	11G	8X
King	Power Equipment Operators	Locomotives, All	\$82.88	15J	11G	8X
King	Power Equipment Operators	Material Transfer Device	\$82.88	15J	11G	8X
King	Power Equipment Operators	Mechanics: All (Leadmen - \$0.50 per hour over mechanic)	\$84.46	15J	11G	8X
King	Power Equipment Operators	Motor Patrol Graders	\$83.62	15J	11G	8X
King	Power Equipment Operators	Mucking Machine, Mole, Tunnel Drill, Boring, Road Header And/or Shield	\$83.62	15J	11G	8X
King	Power Equipment Operators	Oil Distributors, Blower Distribution & Mulch Seeding Operator	\$78.65	15J	11G	8X
King	Power Equipment Operators	Outside Hoists (Elevators and Manlifts), Air Tuggers, Strato	\$82.25	15J	11G	8X
King	Power Equipment Operators	Overhead, bridge type Crane: 20 tons through 44 tons	\$83.20	7A	11H	8X
King	Power Equipment Operators	Overhead, bridge type: 100 tons and over	\$84.77	7A	11H	8X
King	Power Equipment Operators	Overhead, bridge type: 45 tons through 99 tons	\$83.95	7A	11H	8X
King	Power Equipment Operators	Pavement Breaker	\$78.65	15J	11G	8X
King	Power Equipment Operators	Pile Driver (other Than Crane Mount)	\$82.88	15J	11G	8X
King	Power Equipment Operators	Plant Oiler - Asphalt, Crusher	\$82.25	15J	11G	8X
King	Power Equipment Operators	Posthole Digger, Mechanical	\$78.65	15J	11G	8X
King	Power Equipment Operators	Power Plant	\$78.65	15J	11G	8X
King	Power Equipment Operators	Pumps - Water	\$78.65	15J	11G	8X
King	Power Equipment Operators	Quad 9, Hd 41, D10 And Over	\$83.62	15J	11G	8X
King	Power Equipment Operators	Quick Tower: no cab, under 100 feet in height base to boom	\$82.88	15J	11G	8X
King	Power Equipment Operators	Remote Control Operator On Rubber Tired Earth Moving Equipment	\$83.62	15J	11G	8X
King	Power Equipment Operators	Rigger and Bellman	\$78.95	7A	11H	8X
King	Power Equipment Operators	Rigger/Signal Person, Bellman(Certified)	\$82.56	7A	11H	8X

PREVAILING WAGES

8/31/2023

County	Trade	Job Classification	Wage	Holiday	Overtime	Notes
King	Power Equipment Operators	Rollagon	\$83.62	15J	11G	8X
King	Power Equipment Operators	Roller, Other Than Plant Mix	\$78.65	15J	11G	8X
King	Power Equipment Operators	Roller, Plant Mix Or Multi-lift Materials	\$82.25	15J	11G	8X
King	Power Equipment Operators	Roto-mill, Roto-grinder	\$82.88	15J	11G	8X
King	Power Equipment Operators	Saws - Concrete	\$82.25	15J	11G	8X
King	Power Equipment Operators	Scraper, Self Propelled Under 45 Yards	\$82.88	15J	11G	8X
King	Power Equipment Operators	Scrapers - Concrete & Carry All	\$82.25	15J	11G	8X
King	Power Equipment Operators	Scrapers, Self-propelled: 45 Yards And Over	\$83.62	15J	11G	8X
King	Power Equipment Operators	Service Engineers: Equipment	\$82.25	15J	11G	8X
King	Power Equipment Operators	Shotcrete/Gunite Equipment	\$78.65	15J	11G	8X
King	Power Equipment Operators	Shovel, Excavator, Backhoe, Tractors Under 15 Metric Tons	\$82.25	15J	11G	8X
King	Power Equipment Operators	Shovel, Excavator, Backhoe: Over 30 Metric Tons To 50 Metric Tons	\$83.62	15J	11G	8X
King	Power Equipment Operators	Shovel, Excavator, Backhoes, Tractors: 15 To 30 Metric Tons	\$82.88	15J	11G	8X
King	Power Equipment Operators	Shovel, Excavator, Backhoes: Over 50 Metric Tons To 90 Metric Tons	\$84.46	15J	11G	8X
King	Power Equipment Operators	Shovel, Excavator, Backhoes: Over 90 Metric Tons	\$85.33	15J	11G	8X
King	Power Equipment Operators	Slipform Pavers	\$83.62	15J	11G	8X
King	Power Equipment Operators	Spreader, Topsider & Screedman	\$83.62	15J	11G	8X
King	Power Equipment Operators	Subgrader Trimmer	\$82.88	15J	11G	8X
King	Power Equipment Operators	Tower Bucket Elevators	\$82.25	15J	11G	8X
King	Power Equipment Operators	Tower Crane: over 175' through 250' in height, base to boom	\$85.66	7A	11H	8X
King	Power Equipment Operators	Tower crane: up to 175' in height base to boom	\$84.77	7A	11H	8X
King	Power Equipment Operators	Tower Cranes: over 250' in height from base to boom	\$86.48	7A	11H	8X
King	Power Equipment Operators	Transporters, All Track Or Truck Type	\$83.62	15J	11G	8X
King	Power Equipment Operators	Trenching Machines	\$82.25	15J	11G	8X
King	Power Equipment Operators	Truck Crane Oiler/Driver: 100 tons and over	\$83.20	7A	11H	8X
King	Power Equipment Operators	Truck crane oiler/driver: under 100 tons	\$82.56	7A	11H	8X
King	Power Equipment Operators	Truck Mount Portable Conveyor	\$82.88	15J	11G	8X
King	Power Equipment Operators	Vac Truck (Vactor Guzzler, Hydro Excavator)	\$82.88	15J	11G	8X
King	Power Equipment Operators	Welder	\$83.62	15J	11G	8X
King	Power Equipment Operators	Wheel Tractors, Farmall Type	\$78.65	15J	11G	8X
King	Power Equipment Operators	Yo Yo Pay Dozer	\$82.88	15J	11G	8X
King	Surveyors	Assistant Construction Site Surveyor	\$82.56	7A	11H	8X
King	Surveyors	Chainman	\$78.95	7A	11H	8X
King	Surveyors	Construction Site Surveyor	\$83.95	7A	11H	8X
King	Surveyors	Drone Operator (when used in conjunction with survey work only)	\$78.95	7A	11H	8X
King	Surveyors	Ground Penetrating Radar Operator	\$78.95	7A	11H	8X
King	Traffic Control Stripers	Journey Level	\$89.54	15L	11K	
King	Truck Drivers	Asphalt Mix Over 16 Yards	\$74.95	15J	11M	8L
King	Truck Drivers	Asphalt Mix To 16 Yards	\$74.02	15J	11M	8L
King	Truck Drivers	Dump Truck	\$74.02	15J	11M	8L
King	Truck Drivers	Dump Truck & Trailer	\$74.95	15J	11M	8L
King	Truck Drivers	Other Trucks	\$74.95	15J	11M	8L
King	Truck Drivers - Ready Mix	Transit Mix	\$74.95	15J	11M	8L

INTRODUCTION TO THE SPECIAL PROVISIONS

(December 10, 2020 APWA GSP)

The work on this project shall be accomplished in accordance with the *Standard Specifications for Road, Bridge and Municipal Construction*, 2023 edition, as issued by the Washington State Department of Transportation (WSDOT) and the American Public Works Association (APWA), Washington State Chapter (hereafter “Standard Specifications”). The Standard Specifications, as modified or supplemented by these Special Provisions, all of which are made a part of the Contract Documents, shall govern all of the Work.

These Special Provisions are made up of both General Special Provisions (GSPs) from various sources, which may have project-specific fill-ins; and project-specific Special Provisions. Each Provision either supplements, modifies, or replaces the comparable Standard Specification, or is a new Provision. The deletion, amendment, alteration, or addition to any subsection or portion of the Standard Specifications is meant to pertain only to that particular portion of the section, and in no way should it be interpreted that the balance of the section does not apply.

The project-specific Special Provisions are not labeled as such. The GSPs are labeled under the headers of each GSP, with the effective date of the GSP and its source. For example:

(March 8, 2013 APWA GSP)

(April 1, 2013 WSDOT GSP)

(April 12, 2018 CFW GSP)

*(***PROJECT-SPECIFIC SPECIAL PROVISION***)*

Also incorporated into the Contract Documents by reference are:

- *Manual on Uniform Traffic Control Devices for Streets and Highways*, currently adopted edition, with Washington State modifications, if any
- *Standard Plans for Road, Bridge and Municipal Construction*, WSDOT/APWA, current edition
- City of Federal Way Public Works Development Standards
- National Electric Code, current edition

Contractor shall obtain copies of these publications, at Contractor’s own expense.

DIVISION 1 GENERAL REQUIREMENTS

DESCRIPTION OF WORK

(March 13, 1995 WSDOT GSP)

This Contract provides for the improvement of the **On-Call Sidewalk and Curb Replacement** Improvements and other work, all in accordance with the attached Contract Plans, these Contract Provisions, and the Standard Specifications.

1-01.3 Definitions

(January 19, 2022 APWA GSP)

Delete the heading **Completion Dates** and the three paragraphs that follow it, and replace them with the following:

Dates

Bid Opening Date

The date on which the Contracting Agency publicly opens and reads the Bids.

Award Date

The date of the formal decision of the Contracting Agency to accept the lowest responsible and responsive Bidder for the Work.

Contract Execution Date

The date the Contracting Agency officially binds the Agency to the Contract.

Notice to Proceed Date

The date stated in the Notice to Proceed on which the Contract time begins.

Substantial Completion Date

The day the Engineer determines the Contracting Agency has full and unrestricted use and benefit of the facilities, both from the operational and safety standpoint, any remaining traffic disruptions will be rare and brief, and only minor incidental work, replacement of temporary substitute facilities, plant establishment periods, or correction or repair remains for the Physical Completion of the total Contract.

Physical Completion Date

The day all of the Work is physically completed on the project. All documentation required by the Contract and required by law does not necessarily need to be furnished by the Contractor by this date.

Completion Date

The day all the Work specified in the Contract is completed and all the obligations of the Contractor under the contract are fulfilled by the Contractor. All documentation required by the Contract and required by law must be furnished by the Contractor before establishment of this date.

Final Acceptance Date

The date on which the Contracting Agency accepts the Work as complete.

Supplement this Section with the following:

All references in the Standard Specifications, Amendments, or WSDOT General Special Provisions, to the terms "Department of Transportation", "Washington State Transportation Commission", "Commission", "Secretary of Transportation", "Secretary", "Headquarters", and "State Treasurer" shall be revised to read "Contracting Agency."

CITY OF FEDERAL WAY

SP-2

**ON-CALL SIDEWALK AND CURB
REPLACEMENT
PROJECT #101-2023A**

All references to the terms “State” or “state” shall be revised to read “Contracting Agency” unless the reference is to an administrative agency of the State of Washington, a State statute or regulation, or the context reasonably indicates otherwise.

All references to “State Materials Laboratory” shall be revised to read “Contracting Agency designated location.”

All references to “final contract voucher certification” shall be interpreted to mean the Contracting Agency form(s) by which final payment is authorized, and final completion and acceptance granted.

Additive

A supplemental unit of work or group of bid items, identified separately in the Bid Proposal, which may, at the discretion of the Contracting Agency, be awarded in addition to the base bid.

Alternate

One of two or more units of work or groups of bid items, identified separately in the Bid Proposal, from which the Contracting Agency may make a choice between different methods or material of construction for performing the same work.

Business Day

A business day is any day from Monday through Friday except holidays as listed in Section 1-08.5.

Contract Bond

The definition in the Standard Specifications for “Contract Bond” applies to whatever bond form(s) are required by the Contract Documents, which may be a combination of a Payment Bond and a Performance Bond.

Contract Documents

See definition for “Contract.”

Contract Time

The period of time established by the terms and conditions of the Contract within which the Work must be physically completed.

Notice of Award

The written notice from the Contracting Agency to the successful Bidder signifying the Contracting Agency’s acceptance of the Bid Proposal.

Notice to Proceed

The written notice from the Contracting Agency or Engineer to the Contractor authorizing and directing the Contractor to proceed with the Work and establishing the date on which the Contract time begins.

Traffic

Both vehicular and non-vehicular traffic, such as pedestrians, bicyclists, wheelchairs, and equestrian traffic.

1-02 BID PROCEDURES AND CONDITIONS

1-02.1 Prequalification of Bidders

Delete this Section and replace it with the following:

1-02.1 Qualifications of Bidder

(January 24, 2011 APWA GSP)

Before award of a public works Contract, a bidder must meet at least the minimum qualifications of RCW 39.04.350(1) to be considered a responsible bidder and qualified to be awarded a public works project.

1-02.2 Plans and Specifications

(June 27, 2011 APWA GSP)

Delete this section and replace it with the following:

Information as to where Bid Documents can be obtained or reviewed can be found in the Call for Bids (Advertisement for Bids) for the work.

After award of the Contract, Plans and specifications will be issued to the Contractor at no cost as detailed below:

To Prime Contractor	No. of Sets	Basis of Distribution
Reduced Plans (11" x 17")	1	Furnished automatically upon award.
Contract Provisions	1	Furnished automatically upon award.
Large Plans (e.g., 22" x 34")	1	Furnished only upon request.

Additional Plans and Contract Provisions may be obtained by the Contractor from the source stated in the Call for Bids, at the Contractor's own expense.

1-02.4 Examination of Plans, Specifications, and Site Work

(June 27, 2011 APWA GSP)

1-02.4(1) General

(December 30, 2022 APWA GSP, Option B)

The first sentence of the ninth paragraph, beginning with "Prospective Bidder desiring...", is revised to read:

Prospective Bidders desiring an explanation or interpretation of the Bid Documents, shall request the explanation or interpretation in writing by close of business three (3) business days preceding the bid opening to allow a written reply to reach all prospective Bidders before the submission of their Bids.

1-02.5 Proposal Forms

(July 31, 2017 APWA GSP)

Delete this section and replace it with the following:

The Proposal Form will identify the project and its location and describe the work. It will also list estimated quantities, units of measurement, the items of work, and the materials to be furnished at the unit bid prices. The bidder shall complete spaces on the proposal form that call for, but are not limited to, unit prices; extensions; summations; the total bid

amount; signatures; date; and, where applicable, retail sales taxes and acknowledgment of addenda; the bidder's name, address, telephone number, and signature; the bidder's UBDE/DBE/M/WBE commitment, if applicable; a State of Washington Contractor's Registration Number; and a Business License Number, if applicable. Bids shall be completed by typing or shall be printed in ink by hand, preferably in black ink. The required certifications are included as part of the Proposal Form.

The Contracting Agency reserves the right to arrange the proposal forms with alternates and additives, if such be to the advantage of the Contracting Agency. The bidder shall bid on all alternates and additives set forth in the Proposal Form unless otherwise specified.

1-02.7 Bid Deposit
(March 8, 2013 APWA GSP)

Supplement this section with the following:

Bid bonds shall contain the following:

1. Contracting Agency-assigned number for the project;
2. Name of the project;
3. The Contracting Agency named as obligee;
4. The amount of the bid bond stated either as a dollar figure or as a percentage which represents five percent of the maximum bid amount that could be awarded;
5. Signature of the bidder's officer empowered to sign official statements. The signature of the person authorized to submit the bid should agree with the signature on the bond, and the title of the person must accompany the said signature;
6. The signature of the surety's officer empowered to sign the bond and the power of attorney.

If so stated in the Contract Provisions, bidder must use the bond form included in the Contract Provisions.

If so stated in the Contract Provisions, cash will not be accepted for a bid deposit.

1-02.10 Withdrawing, Revising, or Supplementing Proposal
(July 23, 2015 APWA GSP)

Delete this section, and replace it with the following:

After submitting a physical Bid Proposal to the Contracting Agency, the Bidder may withdraw, revise, or supplement it if:

1. The Bidder submits a written request signed by an authorized person and physically delivers it to the place designated for receipt of Bid Proposals, and
2. The Contracting Agency receives the request before the time set for receipt of Bid Proposals, and

3. The revised or supplemented Bid Proposal (if any) is received by the Contracting Agency before the time set for receipt of Bid Proposals.

If the Bidder's request to withdraw, revise, or supplement its Bid Proposal is received before the time set for receipt of Bid Proposals, the Contracting Agency will return the unopened Proposal package to the Bidder. The Bidder must then submit the revised or supplemented package in its entirety. If the Bidder does not submit a revised or supplemented package, then its bid shall be considered withdrawn.

Late revised or supplemented Bid Proposals or late withdrawal requests will be date recorded by the Contracting Agency and returned unopened. Mailed, emailed, or faxed requests to withdraw, revise, or supplement a Bid Proposal are not acceptable.

1-02.13 Irregular Proposals
(December 30, 2022 APWA GSP)

Delete this section and replace it with the following:

1. A Proposal will be considered irregular and will be rejected if:
 - a. The Bidder is not prequalified when so required;
 - b. The authorized Proposal form furnished by the Contracting Agency is not used or is altered;
 - c. The completed Proposal form contains any unauthorized additions, deletions, alternate Bids, or conditions;
 - d. The Bidder adds provisions reserving the right to reject or accept the award, or enter into the Contract;
 - e. A price per unit cannot be determined from the Bid Proposal;
 - f. The Proposal form is not properly executed;
 - g. The Bidder fails to submit or properly complete a subcontractor list (WSDOT Form 271-015), if applicable, as required in Section 1-02.6;
 - h. The Bidder fails to submit or properly complete an Disadvantaged Business Enterprise Certification (WSDOT Form 272-056), if applicable, as required in Section 1-02.6;
 - i. The Bidder fails to submit Written Confirmations (WSDOT Form 422-031) from each DBE firm listed on the Bidder's completed DBE Utilization Certification that they are in agreement with the bidder's DBE participation commitment, if applicable, as required in Section 1-02.6, or if the written confirmation that is submitted fails to meet the requirements of the Special Provisions;
 - j. The Bidder fails to submit DBE Good Faith Effort documentation, if applicable, as required in Section 1-02.6, or if the documentation that is submitted fails to demonstrate that a Good Faith Effort to meet the Condition of Award was made;
 - k. The Bidder fails to submit a DBE Bid Item Breakdown (WSDOT Form 272-054), if applicable, as required in Section 1-02.6, or if the documentation that is submitted fails to meet the requirements of the Special Provisions;
 - l. The Bidder fails to submit DBE Trucking Credit Forms, if applicable, as required in Section 1-02.6, or if the documentation that is submitted fails to meet the requirements of the Special Provisions;
 - m. The Bid Proposal does not constitute a definite and unqualified offer to meet the material terms of the Bid invitation; or
 - n. More than one Proposal is submitted for the same project from a Bidder under the same or different names.

2. A Proposal may be considered irregular and may be rejected if:
 - a. The Proposal does not include a unit price for every Bid item;
 - b. Any of the unit prices are excessively unbalanced (either above or below the amount of a reasonable Bid) to the potential detriment of the Contracting Agency;
 - c. Receipt of Addenda is not acknowledged;
 - d. A member of a joint venture or partnership and the joint venture or partnership submit Proposals for the same project (in such an instance, both Bids may be rejected); or
 - e. If Proposal form entries are not made in ink.

1-02.14 Disqualification of Bidders
(May 17, 2018 APWA GSP, OPTION B)

Delete this section and replace it with the following:

A Bidder will be deemed not responsible if the Bidder does not meet the mandatory bidder responsibility criteria in RCW 39.04.350(1), as amended; or does not meet Supplemental Criteria 1-7 listed in this Section.

Contracting Agency will verify that the Bidder meets the mandatory bidder responsibility criteria in RCW 39.04.350(1), and Supplemental Criteria 1-2. Evidence that the Bidder meets Supplemental Criteria 3-7 shall be provided by the Bidder as stated later in this Section.

1. **Delinquent State Taxes**

- A. Criterion: The Bidder shall not owe delinquent taxes to the Washington State Department of Revenue without a payment plan approved by the Department of Revenue.
- B. Documentation: The Bidder, if and when required as detailed below, shall sign a statement (on a form to be provided by the Contracting Agency) that the Bidder does not owe delinquent taxes to the Washington State Department of Revenue, or if delinquent taxes are owed to the Washington State Department of Revenue, the Bidder must submit a written payment plan approved by the Department of Revenue, to the Contracting Agency by the deadline listed below.

2. **Federal Debarment**

- A. Criterion: The Bidder shall not currently be debarred or suspended by the Federal government.
- B. Documentation: The Bidder shall not be listed as having an “active exclusion” on the U.S. government’s “System for Award Management” database (www.sam.gov).

3. **Subcontractor Responsibility**

- A. Criterion: The Bidder’s standard subcontract form shall include the subcontractor responsibility language required by RCW 39.06.020, and the Bidder shall have an established procedure which it utilizes to validate the responsibility of each of its subcontractors. The Bidder’s subcontract form shall also include a requirement that each of its subcontractors shall have and

document a similar procedure to determine whether the sub-tier subcontractors with whom it contracts are also “responsible” subcontractors as defined by RCW 39.06.020.

- B. Documentation: The Bidder, if and when required as detailed below, shall submit a copy of its standard subcontract form for review by the Contracting Agency, and a written description of its procedure for validating the responsibility of subcontractors with which it contracts.

4. **Claims Against Retainage and Bonds**

A. Criterion: The Bidder shall not have a record of excessive claims filed against the retainage or payment bonds for public works projects in the three years prior to the bid submittal date, that demonstrate a lack of effective management by the Bidder of making timely and appropriate payments to its subcontractors, suppliers, and workers, unless there are extenuating circumstances and such circumstances are deemed acceptable to the Contracting Agency.

B. Documentation: The Bidder, if and when required as detailed below, shall submit a list of the public works projects completed in the three years prior to the bid submittal date that have had claims against retainage and bonds and include for each project the following information:

- Name of project
- The owner and contact information for the owner;
- A list of claims filed against the retainage and/or payment bond for any of the projects listed;
- A written explanation of the circumstances surrounding each claim and the ultimate resolution of the claim.

5. **Public Bidding Crime**

A. Criterion: The Bidder and/or its owners shall not have been convicted of a crime involving bidding on a public works contract in the five years prior to the bid submittal date.

B. Documentation: The Bidder, if and when required as detailed below, shall sign a statement (on a form to be provided by the Contracting Agency) that the Bidder and/or its owners have not been convicted of a crime involving bidding on a public works contract.

6. **Termination for Cause / Termination for Default**

A. Criterion: The Bidder shall not have had any public works contract terminated for cause or terminated for default by a government agency in the five years prior to the bid submittal date, unless there are extenuating circumstances and such circumstances are deemed acceptable to the Contracting Agency.

B. Documentation: The Bidder, if and when required as detailed below, shall sign a statement (on a form to be provided by the Contracting Agency) that the Bidder has not had any public works contract terminated for cause or terminated for default by a government agency in the five years prior to the bid submittal date; or if Bidder was terminated, describe the circumstances. .

7. **Lawsuits**

- A. **Criterion:** The Bidder shall not have lawsuits with judgments entered against the Bidder in the five years prior to the bid submittal date that demonstrate a pattern of failing to meet the terms of contracts, unless there are extenuating circumstances and such circumstances are deemed acceptable to the Contracting Agency

- B. **Documentation:** The Bidder, if and when required as detailed below, shall sign a statement (on a form to be provided by the Contracting Agency) that the Bidder has not had any lawsuits with judgments entered against the Bidder in the five years prior to the bid submittal date that demonstrate a pattern of failing to meet the terms of contracts, or shall submit a list of all lawsuits with judgments entered against the Bidder in the five years prior to the bid submittal date, along with a written explanation of the circumstances surrounding each such lawsuit. The Contracting Agency shall evaluate these explanations to determine whether the lawsuits demonstrate a pattern of failing to meet of terms of construction related contracts

As evidence that the Bidder meets the Supplemental Criteria stated above, the apparent low Bidder must submit to the Contracting Agency by 12:00 P.M. (noon) of the second business day following the bid submittal deadline, a written statement verifying that the Bidder meets the supplemental criteria together with supporting documentation (sufficient in the sole judgment of the Contracting Agency) demonstrating compliance with the Supplemental Criteria. The Contracting Agency reserves the right to request further documentation as needed from the low Bidder and documentation from other Bidders as well to assess Bidder responsibility and compliance with all bidder responsibility criteria. The Contracting Agency also reserves the right to obtain information from third-parties and independent sources of information concerning a Bidder's compliance with the mandatory and supplemental criteria, and to use that information in their evaluation. The Contracting Agency may consider mitigating factors in determining whether the Bidder complies with the requirements of the supplemental criteria.

The basis for evaluation of Bidder compliance with these mandatory and supplemental criteria shall include any documents or facts obtained by Contracting Agency (whether from the Bidder or third parties) including but not limited to: (i) financial, historical, or operational data from the Bidder; (ii) information obtained directly by the Contracting Agency from others for whom the Bidder has worked, or other public agencies or private enterprises; and (iii) any additional information obtained by the Contracting Agency which is believed to be relevant to the matter.

If the Contracting Agency determines the Bidder does not meet the bidder responsibility criteria above and is therefore not a responsible Bidder, the Contracting Agency shall notify the Bidder in writing, with the reasons for its determination. If the Bidder disagrees with this determination, it may appeal the determination within two (2) business days of the Contracting Agency's determination by presenting its appeal and any additional information to the Contracting Agency. The Contracting Agency will consider the appeal and any additional information before issuing its final determination. If the final determination affirms that the Bidder is not responsible, the Contracting Agency will not execute a contract with any other Bidder until at least two business days after the Bidder

determined to be not responsible has received the Contracting Agency's final determination.

Request to Change Supplemental Bidder Responsibility Criteria Prior To Bid: Bidders with concerns about the relevancy or restrictiveness of the Supplemental Bidder Responsibility Criteria may make or submit requests to the Contracting Agency to modify the criteria. Such requests shall be in writing, describe the nature of the concerns, and propose specific modifications to the criteria. Bidders shall submit such requests to the Contracting Agency no later than five (5) business days prior to the bid submittal deadline and address the request to the Project Engineer or such other person designated by the Contracting Agency in the Bid Documents.

1-03 AWARD AND EXECUTION OF CONTRACT

1-03.1 Consideration of Bids ***(December 30, 2022 APWA GSP)***

Revise the first paragraph to read:

After opening and reading proposals, the Contracting Agency will check them for correctness of extensions of the prices per unit and the total price. If a discrepancy exists between the price per unit and the extended amount of any bid item, the price per unit will control. If a minimum bid amount has been established for any item and the bidder's unit or lump sum price is less than the minimum specified amount, the Contracting Agency will unilaterally revise the unit or lump sum price, to the minimum specified amount and recalculate the extension. The total of extensions, corrected where necessary, including sales taxes where applicable and such additives and/or alternates as selected by the Contracting Agency, will be used by the Contracting Agency for award purposes and to fix the Awarded Contract Price amount and the amount of the contract bond.

1-03.1(1) Identical Bid Totals ***(December 30, 2022 APWA GSP)***

Revise this section to read:

After opening Bids, if two or more lowest responsive Bid totals are exactly equal, then the tie-breaker will be the Bidder with an equal lowest bid, that proposed to use the highest percentage of recycled materials in the Project, per the form submitted with the Bid Proposal. If those percentages are also exactly equal, then the tie-breaker will be determined by drawing as follows: Two or more slips of paper will be marked as follows: one marked "Winner" and the other(s) marked "unsuccessful." The slips will be folded to make the marking unseen. The slips will be placed inside a box. One authorized representative of each Bidder shall draw a slip from the box. Bidders shall draw in alphabetic order by the name of the firm as registered with the Washington State Department of Licensing. The slips shall be unfolded and the firm with the slip marked "Winner" will be determined to be the successful Bidder and eligible for Award of the Contract. Only those Bidders who submitted a Bid total that is exactly equal to the lowest responsive Bid, and with a proposed recycled materials percentage that is exactly equal to the highest proposed recycled materials amount, are eligible to draw.

1-03.3 Execution of Contract ***(January 19, 2022 APWA GSP)***

Revise this section to read:

CITY OF FEDERAL WAY

SP-10

**ON-CALL SIDEWALK AND CURB
REPLACEMENT
PROJECT #101-2023A**

Within 3 calendar days of Award date (not including Saturdays, Sundays, and Holidays), the successful Bidder shall provide the information necessary to execute the Contract to the Contracting Agency. The Bidder shall send the contact information, including the full name, email address, and phone number, for the authorized signer and bonding agent to the Contracting Agency.

Copies of the Contract Provisions, including the unsigned Form of Contract, will be available for signature by the successful bidder on the first business day following award. The number of copies to be executed by the Contractor will be determined by the Contracting Agency.

Within 10 calendar days after the award date, the successful bidder shall return the signed Contracting Agency-prepared contract, an insurance certification as required by Section 1-07.18, and a satisfactory bond as required by law and Section 1-03.4, the Transfer of Coverage form for the Construction Stormwater General Permit with sections I, III, and VIII completed when provided. Before execution of the contract by the Contracting Agency, the successful bidder shall provide any pre-award information the Contracting Agency may require under Section 1-02.15.

Until the Contracting Agency executes a contract, no proposal shall bind the Contracting Agency nor shall any work begin within the project limits or within Contracting Agency-furnished sites. The Contractor shall bear all risks for any work begun outside such areas and for any materials ordered before the contract is executed by the Contracting Agency.

If the bidder experiences circumstances beyond their control that prevents return of the contract documents within the calendar days after the award date stated above, the Contracting Agency may grant up to a maximum of 5 additional calendar days for return of the documents, provided the Contracting Agency deems the circumstances warrant it.

1-03.4 Contract Bond
(July 23, 2015 APWA GSP)

Delete the first paragraph and replace it with the following:

The successful bidder shall provide executed payment and performance bond(s) for the full contract amount. The bond may be a combined payment and performance bond; or be separate payment and performance bonds. In the case of separate payment and performance bonds, each shall be for the full contract amount. The bond(s) shall:

1. Be on Contracting Agency-furnished form(s);
2. Be signed by an approved surety (or sureties) that:
 - a. Is registered with the Washington State Insurance Commissioner, and
 - b. Appears on the current Authorized Insurance List in the State of Washington published by the Office of the Insurance Commissioner,
3. Guarantee that the Contractor will perform and comply with all obligations, duties, and conditions under the Contract, including but not limited to the duty and obligation to indemnify, defend, and protect the Contracting

Agency against all losses and claims related directly or indirectly from any failure:

- a. Of the Contractor (or any of the employees, subcontractors, or lower tier subcontractors of the Contractor) to faithfully perform and comply with all contract obligations, conditions, and duties, or
 - b. Of the Contractor (or the subcontractors or lower tier subcontractors of the Contractor) to pay all laborers, mechanics, subcontractors, lower tier subcontractors, material person, or any other person who provides supplies or provisions for carrying out the work;
4. Be conditioned upon the payment of taxes, increases, and penalties incurred on the project under titles 50, 51, and 82 RCW; and
 5. Be accompanied by a power of attorney for the Surety's officer empowered to sign the bond; and
 6. Be signed by an officer of the Contractor empowered to sign official statements (sole proprietor or partner). If the Contractor is a corporation, the bond(s) must be signed by the president or vice president, unless accompanied by written proof of the authority of the individual signing the bond(s) to bind the corporation (i.e., corporate resolution, power of attorney, or a letter to such effect signed by the president or vice president).

1-03.7 Judicial Review
(December 30, 2022 APWA GSP)

Revise this section to read:

All decision made by the Contracting Agency regarding the Award and execution of the Contract or Bid rejection shall be conclusive subject to the scope of judicial review permitted under Washington Law. Such review, if any, shall be timely filed in the Superior Court of the county where the Contracting Agency headquarters is located, provided that where an action is asserted against a county, RCW 36.01.050 shall control venue and jurisdiction.

1-04 SCOPE OF THE WORK

1-04.2 Coordination of Contract Documents, Plans, Special Provisions, Specifications, and Addenda

(January 8, 2021 CFW GSP)

Revise the second paragraph to read:

Any inconsistency in the parts of the contract shall be resolved by following this order of precedence (e.g., 1 presiding over 2, 2 over 3, 3 over 4, and so forth):

1. Contract,
2. Change Orders, with those of a later date taking precedence of those of an earlier date,
3. Addenda, with those of a later date taking precedence of those of an earlier date,
4. Proposal Form,
5. Special Provisions,

6. Contract Plans,
7. Standard Specifications,
8. Contracting Agency's Standard Plans or Details (if any), and
9. WSDOT Standard Plans for Road, Bridge, and Municipal Construction.

1-04.4 Changes

(January 19, 2022 APWA GSP)

The first two sentences of the last paragraph of Section 1-04.4 are deleted.

1-05 CONTROL OF WORK

1-05.4 Conformity With and Deviations from Plans and Stakes

(January 13, 2021 WSDOT GSP, OPTION 2)

Section 1-05.4 is supplemented with the following:

Contractor Surveying – Roadway

The Contracting Agency has provided primary survey control in the Plans.

The Contractor shall be responsible for setting, maintaining, and resetting all alignment stakes, slope stakes, and grades necessary for the construction of the roadbed, drainage, surfacing, paving, channelization and pavement marking, illumination and signals, guardrails and barriers, and signing. Except for the survey control data to be furnished by the Contracting Agency, calculations, surveying, and measuring required for setting and maintaining the necessary lines and grades shall be the Contractor's responsibility.

The Contractor shall inform the Engineer when monuments are discovered that were not identified in the Plans and construction activity may disturb or damage the monuments. All monuments noted on the plans "DO NOT DISTURB" shall be protected throughout the length of the project or be replaced at the Contractors expense.

Detailed survey records shall be maintained, including a description of the work performed on each shift, the methods utilized, and the control points used. The record shall be adequate to allow the survey to be reproduced. A copy of each day's record shall be provided to the Engineer within three working days after the end of the shift.

The meaning of words and terms used in this provision shall be as listed in "Definitions of Surveying and Associated Terms" current edition, published by the American Congress on Surveying and Mapping and the American Society of Civil Engineers.

The survey work shall include but not be limited to the following:

1. Verify the primary horizontal and vertical control furnished by the Contracting Agency, and expand into secondary control by adding stakes and hubs as well as additional survey control needed for the project. Provide descriptions of secondary control to the Contracting Agency. The description shall include coordinates and elevations of all secondary control points.

2. Establish, the centerlines of all alignments, by placing hubs, stakes, or marks on centerline or on offsets to centerline at all curve points (PCs, PTs, and PIs) and at points on the alignments spaced no further than 50 feet.
3. Establish clearing limits, placing stakes at all angle points and at intermediate points not more than 50 feet apart. The clearing and grubbing limits shall be 5 feet beyond the toe of a fill and 10 feet beyond the top of a cut unless otherwise shown in the Plans.
4. Establish grading limits, placing slope stakes at centerline increments not more than 50 feet apart. Establish offset reference to all slope stakes. If Global Positioning Satellite (GPS) Machine Controls are used to provide grade control, then slope stakes may be omitted at the discretion of the Contractor
5. Establish the horizontal and vertical location of all drainage features, placing offset stakes to all drainage structures and to pipes at a horizontal interval not greater than 25 feet.
6. Establish roadbed and surfacing elevations by placing stakes at the top of subgrade and at the top of each course of surfacing. Subgrade and surfacing stakes shall be set at horizontal intervals not greater than 50 feet in tangent sections, 25 feet in curve sections with a radius less than 300 feet, and at 10-foot intervals in intersection radii with a radius less than 10 feet. Transversely, stakes shall be placed at all locations where the roadway slope changes and at additional points such that the transverse spacing of stakes is not more than 12 feet. If GPS Machine Controls are used to provide grade control, then roadbed and surfacing stakes may be omitted at the discretion of the Contractor.
7. Establish intermediate elevation benchmarks as needed to check work throughout the project.
8. Provide references for paving pins at 25-foot intervals or provide simultaneous surveying to establish location and elevation of paving pins as they are being placed.
9. For all other types of construction included in this provision, (including but not limited to channelization and pavement marking, illumination and signals, guardrails and barriers, and signing) provide staking and layout as necessary to adequately locate, construct, and check the specific construction activity.
10. Contractor shall determine if changes are needed to the profiles or roadway sections shown in the Contract Plans in order to achieve proper smoothness and drainage where matching into existing features, such as a smooth transition from new pavement to existing pavement. The Contractor shall submit these changes to the Engineer for review and approval 10 days prior to the beginning of work.

The Contractor shall provide the Contracting Agency copies of any calculations and staking data when requested by the Engineer.

The Contractor shall ensure a surveying accuracy within the following tolerances:

CITY OF FEDERAL WAY

SP-14

**ON-CALL SIDEWALK AND CURB
REPLACEMENT
PROJECT #101-2023A**

	<u>Vertical</u>	<u>Horizontal</u>
Slope stakes	±0.10 feet	±0.10 feet
Subgrade grade stakes set 0.04 feet below grade	±0.01 feet	±0.5 feet (parallel to alignment) ±0.1 feet (normal to alignment)
Stationing on roadway	N/A	±0.1 feet
Alignment on roadway	N/A	±0.04 feet
Surfacing grade stakes	±0.01 feet	±0.5 feet (parallel to alignment) ±0.1 feet (normal to alignment)
Roadway paving pins for surfacing or paving	±0.01 feet	±0.2 feet (parallel to alignment) ±0.1 feet (normal to alignment)

The Contracting Agency may spot-check the Contractor's surveying. These spot-checks will not change the requirements for normal checking by the Contractor.

When staking roadway alignment and stationing, the Contractor shall perform independent checks from different secondary control to ensure that the points staked are within the specified survey accuracy tolerances.

The Contractor shall calculate coordinates for the alignment. The Contracting Agency will verify these coordinates prior to issuing approval to the Contractor for commencing with the work. The Contracting Agency will require up to seven calendar days from the date the data is received.

Contract work to be performed using contractor-provided stakes shall not begin until the stakes are approved by the Contracting Agency. Such approval shall not relieve the Contractor of responsibility for the accuracy of the stakes.

Stakes shall be marked in accordance with Standard Plan A10.10. When stakes are needed that are not described in the Plans, then those stakes shall be marked, at no additional cost to the Contracting Agency as ordered by the Engineer.

Payment

Payment will be made for the following bid item when included in the proposal:

"Roadway Surveying", lump sum.

The lump sum contract price for "Roadway Surveying" shall be full pay for all labor, equipment, materials, and supervision utilized to perform the Work specified, including

any resurveying, checking, correction of errors, replacement of missing or damaged stakes, and coordination efforts.

(March 9, 2023, WSDOT GSP, OPTION 4)

Section 1-05.4 is supplemented with the following:

Contractor Surveying - ADA Features

ADA Feature Staking Requirements

The Contractor shall be responsible for setting, maintaining, and resetting all alignment stakes, and grades necessary for the construction of the ADA features. Calculations, surveying, and measuring required for setting and maintaining the necessary lines and grades shall be the Contractor's responsibility. The Contractor shall build the ADA features within the specifications in the Standard Plans and contract documents.

ADA Feature Contract Compliance

The Contractor shall be responsible for completing measurements to verify all ADA features comply with the Contract in the presence of the Engineer.

ADA Feature As-Built Measurements

The Contractor shall be responsible for providing the latitude and longitude of each ADA feature as indicated on the ADA Inspection Form(s) (WSDOT Form 224-020).

The completed ADA Inspection Form(s) (WSDOT Form 224-020) shall be submitted as a Type 3 Working Drawing and transmitted to the Engineer within 30 calendar days of completing the ADA feature. After acceptance, the Contracting Agency will submit the final form(s) to the WSDOT ADA Steward.

Payment

Payment will be made for the following bid item that is included in the Proposal:

"ADA Features Surveying", lump sum.

The lump sum Contract price for "ADA Features Surveying" shall be full pay for all the Work as specified.

In the instance where an ADA feature does not meet accessibility requirements, all work to replace non-compliant work and then to measure, record the as-built measurements, and transmit the electronic forms to the Engineer shall be completed at no additional cost to the Contracting Agency.

1-05.7 Removal of Defective and Unauthorized Work

(October 1, 2005 APWA GSP)

Supplement this section with the following:

If the Contractor fails to remedy defective or unauthorized work within the time specified in a written notice from the Engineer, or fails to perform any part of the work required by the Contract Documents, the Engineer may correct and remedy such work as may be identified in the written notice, with Contracting Agency forces or by such other means as the Contracting Agency may deem necessary.

If the Contractor fails to comply with a written order to remedy what the Engineer determines to be an emergency situation, the Engineer may have the defective and

unauthorized work corrected immediately, have the rejected work removed and replaced, or have work the Contractor refuses to perform completed by using Contracting Agency or other forces. An emergency situation is any situation when, in the opinion of the Engineer, a delay in its remedy could be potentially unsafe, or might cause serious risk of loss or damage to the public.

Direct or indirect costs incurred by the Contracting Agency attributable to correcting and remedying defective or unauthorized work, or work the Contractor failed or refused to perform, shall be paid by the Contractor. Payment will be deducted by the Engineer from monies due, or to become due, the Contractor. Such direct and indirect costs shall include in particular, but without limitation, compensation for additional professional services required, and costs for repair and replacement of work of others destroyed or damaged by correction, removal, or replacement of the Contractor's unauthorized work.

No adjustment in Contract time or compensation will be allowed because of the delay in the performance of the work attributable to the exercise of the Contracting Agency's rights provided by this section.

The rights exercised under the provisions of this section shall not diminish the Contracting Agency's right to pursue any other avenue for additional remedy or damages with respect to the Contractor's failure to perform the work as required.

1-05.11 Final Inspection
(October 1, 2005 APWA GSP)

Delete this section and replace it with the following:

1-05.11 Final Inspections and Operational Testing

1-05.11(1) Substantial Completion Date

When the Contractor considers the work to be substantially complete, the Contractor shall so notify the Engineer and request the Engineer establish the Substantial Completion Date. The Contractor's request shall list the specific items of work that remain to be completed in order to reach physical completion. The Engineer will schedule an inspection of the work with the Contractor to determine the status of completion. The Engineer may also establish the Substantial Completion Date unilaterally.

If, after this inspection, the Engineer concurs with the Contractor that the work is substantially complete and ready for its intended use, the Engineer, by written notice to the Contractor, will set the Substantial Completion Date. If, after this inspection the Engineer does not consider the work substantially complete and ready for its intended use, the Engineer will, by written notice, so notify the Contractor giving the reasons therefore.

Upon receipt of written notice concurring in or denying substantial completion, whichever is applicable, the Contractor shall pursue vigorously, diligently and without unauthorized interruption, the work necessary to reach Substantial and Physical Completion. The Contractor shall provide the Engineer with a revised schedule indicating when the Contractor expects to reach substantial and physical completion of the work.

The above process shall be repeated until the Engineer establishes the Substantial Completion Date and the Contractor considers the work physically complete and ready for final inspection.

1-05.11(2) Final Inspection and Physical Completion Date

When the Contractor considers the work physically complete and ready for final inspection, the Contractor by written notice, shall request the Engineer to schedule a final inspection. The Engineer will set a date for final inspection. The Engineer and the Contractor will then make a final inspection and the Engineer will notify the Contractor in writing of all particulars in which the final inspection reveals the work incomplete or unacceptable. The Contractor shall immediately take such corrective measures as are necessary to remedy the listed deficiencies. Corrective work shall be pursued vigorously, diligently, and without interruption until physical completion of the listed deficiencies. This process will continue until the Engineer is satisfied the listed deficiencies have been corrected.

If action to correct the listed deficiencies is not initiated within 7 days after receipt of the written notice listing the deficiencies, the Engineer may, upon written notice to the Contractor, take whatever steps are necessary to correct those deficiencies pursuant to Section 1-05.7.

The Contractor will not be allowed an extension of Contract time because of a delay in the performance of the work attributable to the exercise of the Engineer's right hereunder.

Upon correction of all deficiencies, the Engineer will notify the Contractor and the Contracting Agency, in writing, of the date upon which the work was considered physically complete. That date shall constitute the Physical Completion Date of the Contract, but shall not imply acceptance of the work or that all the obligations of the Contractor under the Contract have been fulfilled.

1-05.11(3) Operational Testing

It is the intent of the Contracting Agency to have at the Physical Completion Date a complete and operable system. Therefore when the work involves the installation of machinery or other mechanical equipment; street lighting, electrical distribution or signal systems; irrigation systems; buildings; or other similar work it may be desirable for the Engineer to have the Contractor operate and test the work for a period of time after final inspection but prior to the physical completion date. Whenever items of work are listed in the Contract Provisions for operational testing they shall be fully tested under operating conditions for the time period specified to ensure their acceptability prior to the Physical Completion Date. During and following the test period, the Contractor shall correct any items of workmanship, materials, or equipment which prove faulty, or that are not in first class operating condition. Equipment, electrical controls, meters, or other devices and equipment to be tested during this period shall be tested under the observation of the Engineer, so that the Engineer may determine their suitability for the purpose for which they were installed. The Physical Completion Date cannot be established until testing and corrections have been completed to the satisfaction of the Engineer.

The costs for power, gas, labor, material, supplies, and everything else needed to successfully complete operational testing, shall be included in the unit Contract prices related to the system being tested, unless specifically set forth otherwise in the Proposal.

Operational and test periods, when required by the Engineer, shall not affect a manufacturer's guaranties or warranties furnished under the terms of the Contract.

1-05.12 Final Acceptance
(April 12, 2019 CFW GSP)

Delete the third and fourth sentences in the first paragraph and replace it with the following:
Final acceptance date of the work shall be the date the Federal Way City Council accepts the project as complete.

Add the following new section.

1-05.12(1) One-Year Guarantee Period
(March 8, 2013 APWA GSP)

The Contractor shall return to the project and repair or replace all defects in workmanship and material discovered within one year after Final Acceptance of the Work. The Contractor shall start work to remedy any such defects within 7 calendar days of receiving Contracting Agency's written notice of a defect, and shall complete such work within the time stated in the Contracting Agency's notice. In case of an emergency, where damage may result from delay or where loss of services may result, such corrections may be made by the Contracting Agency's own forces or another contractor, In which case the cost of corrections shall be paid by the Contractor. In the event the Contractor does not accomplish corrections within the time specified, the work will be otherwise accomplished and the cost of same shall be paid by the Contractor.

When corrections of defects are made, the Contractor shall then be responsible for correcting all defects in workmanship and materials in the corrected work for one year after acceptance of the corrections by Contracting Agency.

This guarantee is supplemental to and does not limit or affect the requirements that the Contractor's work comply with the requirements of the Contract or any other legal rights or remedies of the Contracting Agency.

1-05.13 Superintendents, Labor and Equipment of Contractor
(August 14, 2013 APWA GSP)

Delete the sixth and seventh paragraphs of this section.

1-05.15 Method of Serving Notices
(December 30, 2022 APWA GSP)

Revise the second paragraph to read:

All correspondence from the Contractor shall be directed to the Project Engineer. All correspondence from the Contractor constituting any notification, notice of protest, notice of dispute, or other correspondence constituting notification required to be furnished under the Contract, must be in paper format, hand delivered or sent via mail delivery service to the Project Engineer's office. Electronic copies such as e-mails or electronically delivered copies of correspondence will not constitute such notice and will not comply with the requirements of the Contract.

Add the following new section:

1-05.16 Water and Power

CITY OF FEDERAL WAY

SP-19

ON-CALL SIDEWALK AND CURB
REPLACEMENT
PROJECT #101-2023A

(October 1, 2005 APWA GSP)

The Contractor shall make necessary arrangements, and shall bear the costs for power and water necessary for the performance of the work, unless the Contract includes power and water as a pay item.

1-05.18 Contractor's Daily Diary

(March 22, 2023 CFW GSP)

Section 1-05.18 is a new section:

The Contractor and subcontractors, as additional consideration for payment for this contract work, hereby agree to maintain and provide to the Owner and the Engineer a Daily Diary Record of this Work. The diary must be kept and maintained by the Contractor's designated project superintendent. Entries must be made on a daily basis and must accurately represent all of the project activities on each day.

At a minimum, the diary shall show on a daily basis:

- The day and date.
- The weather conditions, including changes throughout the day.
- A complete description of work accomplished during the day with adequate references to the Plans and Specifications so that the reader can easily and accurately identify said work in the Plans.
- An entry for each and every changed condition, dispute or potential dispute, incident, accident, or occurrence of any nature whatsoever which might affect the Contract, Owner, or any third party in any manner.
- Listing of any materials received and stored on or off-site by the Contractor for future installation, to include the manner of storage and protection of the same.
- Listing of materials installed during each day.
- List of all subcontractors working on-site during each day.
- Listing of the number of Contractor's employees working during each day by category of employment.
- Listing of Contractor's equipment working on the site during each day. Idle equipment on the site shall be listed and designated as idle.
- Notations to explain inspections, testing, stake-out, and all other services furnished to the Contractor by the Owner or other during each day.
- Entries to verify the daily (including non-work days) inspection and maintenance of traffic control devices and condition of the traveled roadway surfaces. The Contractor shall not allow any conditions to develop that would be hazardous to the public.
- Any other information that serves to give an accurate and complete record of the nature, quantity, and quality of the Contractor's progress on each day.
- Summary of total number of working days to date, and total number of delay days to date.

The Contractor's designated project superintendent must sign the diary at the end of each working day. The Contractor must provide a copy of the diary to the Owner and the Engineer each morning for the preceding workday. All copies must be legible.

It is expressly agreed between the contractor and the owner that the daily diary maintained by the Contractor shall be the "Contractor's Book of Original Entry" for the documentation of any potential claims or disputes that might arise during this contract. Failure of the

Contractor to maintain this diary in the manner described above will constitute a waiver of any such claims or disputes by the Contractor. The daily diary maintained by the Contractor does not constitute the official record of the project. The official record of the project is prepared and maintained exclusively by the engineer.

1-05.19 Defects Arising in One Year and Remedies
(February 15, 2019 CFW GSP)

Section 1-05.19 is a new section:

The Contractor shall, at its own sole cost and expense, be responsible for correcting all defects in workmanship and material discovered within one year after acceptance of this work by the City of Federal Way. When corrections of defects are made, the Contractor shall be responsible for correcting all defects in workmanship and/or materials in the corrected work for one year after acceptance of the corrections by the Owner. Conducting of tests and inspections, review of specifications or plans, payment for goods or services, or acceptance by the City does not constitute waiver, modification, or exclusion of any express or implied warranty or any right under law. This warranty shall survive termination of this Contract.

The Contractor shall start work to remedy such defects within seven (7) calendar days of mailing notice of discovery thereof by the Owner and shall complete such work within a reasonable time. In emergencies, where damage may result from delay or where loss of services may result, such corrections may be made by the Owner, in which case the cost shall be borne by the Contractor. In the event the Contractor does not accomplish corrections at the time specified, the work will be otherwise accomplished and the cost of same shall be paid by the Contractor. These actions will be pursuant to the provisions of Section 1-05.8 of the Standard Specifications.

The Contractor shall be liable for any costs, losses, expenses, or damages, including consequential damages suffered by the Owner resulting from defects in the Contractor's work including, but not limited to, cost of materials and labor extended by Owner in making emergency repairs and cost of engineering, inspection and supervision by the Owner or the Engineer. The Contractor shall hold the Owner harmless from any and all claims which may be made against the Owner as a result of any defective work, and the Contractor shall defend any such claims at his own expense.

The Contractor agrees the above one-year limitation shall not exclude or diminish the Owner's rights under any law to obtain damages and recover costs resulting from defective and unauthorized work discovered after one year but prior to the expiration of the legal time period set forth in RCW 9.16.040 limiting actions upon a contract in writing or liability, expressed or implied, arising out of a written agreement. This warranty may also extend beyond the one year time period pursuant to any other warranties specified in the Special Provisions, Contract Plans, other parts of the Contract Documents, or incorporated by this reference.

1-06 CONTROL OF MATERIAL

1-06.6 Recycled Materials
(January 4, 2016 APWA GSP)

CITY OF FEDERAL WAY

SP-21

ON-CALL SIDEWALK AND CURB
REPLACEMENT
PROJECT #101-2023A

Delete this section, including its subsections, and replace it with the following:

The Contractor shall make their best effort to utilize recycled materials in the construction of the project. Approval of such material use shall be as detailed elsewhere in the Standard Specifications.

Prior to Physical Completion the Contractor shall report the quantity of recycled materials that were utilized in the construction of the project for each of the items listed in Section 9-03.21. The report shall include hot mix asphalt, recycled concrete aggregate, recycled glass, steel furnace slag and other recycled materials (e.g. utilization of on-site material and aggregates from concrete returned to the supplier). The Contractor's report shall be provided on DOT form 350-075 Recycled Materials Reporting.

1-07 LEGAL RELATIONS AND RESPONSIBILITIES TO THE PUBLIC

1-07.1 Laws to be Observed

(October 1, 2005 APWA GSP)

Supplement this section with the following:

In cases of conflict between different safety regulations, the more stringent regulation shall apply.

The Washington State Department of Labor and Industries shall be the sole and paramount administrative agency responsible for the administration of the provisions of the Washington Industrial Safety and Health Act of 1973 (WISHA).

The Contractor shall maintain at the project site office, or other well-known place at the project site, all articles necessary for providing first aid to the injured. The Contractor shall establish, publish, and make known to all employees, procedures for ensuring immediate removal to a hospital, or doctor's care, persons, including employees, who may have been injured on the project site. Employees should not be permitted to work on the project site before the Contractor has established and made known procedures for removal of injured persons to a hospital or a doctor's care.

The Contractor shall have sole responsibility for the safety, efficiency, and adequacy of the Contractor's Plant, appliances, and methods, and for any damage or injury resulting from their failure, or improper maintenance, use, or operation. The Contractor shall be solely and completely responsible for the conditions of the project site, including safety for all persons and property in the performance of the work. This requirement shall apply continuously, and not be limited to normal working hours. The required or implied duty of the Engineer to conduct construction review of the Contractor's performance does not, and shall not, be intended to include review and adequacy of the Contractor's safety measures in, on, or near the project site.

1-07.2 State Taxes

Delete this section, including its sub-sections, in its entirety and replace it with the following:

1-07.2 State Sales Tax

(June 27, 2011 APWA GSP)

CITY OF FEDERAL WAY

SP-22

**ON-CALL SIDEWALK AND CURB
REPLACEMENT
PROJECT #101-2023A**

The Washington State Department of Revenue has issued special rules on the State sales tax. Sections 1-07.2(1) through 1-07.2(3) are meant to clarify those rules. The Contractor should contact the Washington State Department of Revenue for answers to questions in this area. The Contracting Agency will not adjust its payment if the Contractor bases a Bid on a misunderstood tax liability.

The Contractor shall include all Contractor-paid taxes in the unit Bid prices or other Contract amounts. In some cases, however, state retail sales tax will not be included. Section 1-07.2(2) describes this exception.

The Contracting Agency will pay the retained percentage (or release the Contract Bond if a FHWA-funded Project) only if the Contractor has obtained from the Washington State Department of Revenue a certificate showing that all Contract-related taxes have been paid (RCW 60.28.051). The Contracting Agency may deduct from its payments to the Contractor any amount the Contractor may owe the Washington State Department of Revenue, whether the amount owed relates to this Contract or not. Any amount so deducted will be paid into the proper State fund.

1-07.2(1) State Sales Tax — Rule 171

WAC 458-20-171, and its related rules, apply to building, repairing, or improving streets, roads, etc., which are owned by a municipal corporation, or political subdivision of the state, or by the United States, and which are used primarily for foot or vehicular traffic. This includes storm or combined sewer systems within and included as a part of the street or road drainage system and power lines when such are part of the roadway lighting system. For work performed in such cases, the Contractor shall include Washington State Retail Sales Taxes in the various unit Bid item prices, or other Contract amounts, including those that the Contractor pays on the purchase of the materials, equipment, or supplies used or consumed in doing the work.

1-07.2(2) State Sales Tax — Rule 170

WAC 458-20-170, and its related rules, apply to the constructing and repairing of new or existing buildings, or other structures, upon real property. This includes, but is not limited to, the construction of streets, roads, highways, etc., owned by the state of Washington; water mains and their appurtenances; sanitary sewers and sewage disposal systems unless such sewers and disposal systems are within, and a part of, a street or road drainage system; telephone, telegraph, electrical power distribution lines, or other conduits or lines in or above streets or roads, unless such power lines become a part of a street or road lighting system; and installing or attaching of any article of tangible personal property in or to real property, whether or not such personal property becomes a part of the realty by virtue of installation.

For work performed in such cases, the Contractor shall collect from the Contracting Agency, retail sales tax on the full Contract price. The Contracting Agency will automatically add this sales tax to each payment to the Contractor. For this reason, the Contractor shall not include the retail sales tax in the unit Bid item prices, or in any other Contract amount subject to Rule 170, with the following exception.

Exception: The Contracting Agency will not add in sales tax for a payment the Contractor or a subcontractor makes on the purchase or rental of tools, machinery, equipment, or consumable supplies not integrated into the project. Such sales taxes shall be included in the unit Bid item prices or in any other Contract amount.

1-07.2(3) Services

The Contractor shall not collect retail sales tax from the Contracting Agency on any Contract wholly for professional or other services (as defined in Washington State Department of Revenue Rules 138 and 244).

1-07.6 Permits and Licenses

(April 12, 2018 CFW GSP)

Section 1-07.6 is supplemented with the following:

Survey Monuments

In accordance with RCW 58.24.040(8), no cadastral or geodetic survey monument may be disturbed without a valid permit to remove or destroy a survey monument, issued by the Washington State Department of Natural Resources. Permit applications can be obtained on the DNR Public Land Survey Office website. The permit application must be stamped by a registered Washington State Land Surveyor. The Contractor shall obtain the permit to Remove or Destroy a Survey Monument as necessary. All costs to obtain and comply with the permit shall be considered incidental to other bid items and no additional payment will be made.

(December 16, 2022 CFW GSP)

Section 1-07.6 is supplemented with the following:

Oversized Loads

The Contractor must obtain a permit from the City of Federal Way (Development Services Division) for any Oversize / Overweight Loads. Loads are classified as oversized / overweight if they exceed the following criteria:

Size

- 8'6" wide, 14' tall, 53' length (tractor/trailer)
- 40' single unit
- 75' overall with a truck and trailer
- 3' of front overhang and 15' of rear overhang

Weight

- Heavy loads require a permit for overweight if they exceed the vehicle weight table published by WSDOT. The gross vehicle weight for a vehicle or a vehicle combination is determined by an overlapping set of three criteria: tire size, axle weight, and the weight table.

(January 2, 2018 WSDOT GSP, OPTION 1)

Section 1-07.6 is supplemented with the following:

The Contracting Agency has obtained the below-listed permit(s) for this project. A copy of the permit(s) is attached as an appendix for informational purposes. Copies of these permits, including a copy of the Transfer of Coverage form, when applicable, are required to be onsite at all times.

Contact with the permitting agencies, concerning the below-listed permit(s), shall be made through the Engineer with the exception of when the Construction Stormwater General Permit coverage is transferred to the Contractor, direct communication with the Department of Ecology is allowed. The Contractor shall be responsible for obtaining Ecology's approval for any Work requiring additional approvals (e.g. Request for Chemical Treatment Form). The Contractor shall obtain additional permits as necessary. All costs to obtain and comply with additional permits shall be included in the applicable Bid items for the Work involved.

- Construction Stormwater General Permit
- Any other permits included in Appendices

1-07.7 Load Limits

(March 13, 1995 WSDOT GSP, OPTION 6)

Section 1-07.7 is supplemented with the following:

If the sources of materials provided by the Contractor necessitate hauling over roads other than State Highways, the Contractor shall, at the Contractor's expense, make all arrangements for the use of the haul routes.

1-07.16 Protection and Restoration of Property

1-07.16(2) Vegetation Protection and Restoration

(August 2, 2010 WSDOT GSP)

Section 1-07.16(2) is supplemented with the following:

Vegetation and soil protection zones for trees shall extend out from the trunk to a distance of 1 foot radius for each inch of trunk diameter at breast height.

Vegetation and soil protection zones for shrubs shall extend out from the stems at ground level to twice the radius of the shrub.

Vegetation and soil protection zones for herbaceous vegetation shall extend to encompass the diameter of the plant as measured from the outer edge of the plant.

1-07.17 Utilities and Similar Facilities

(April 2, 2007 WSDOT GSP, OPTION 1)

Section 1-07.17 is supplemented with the following:

Locations and dimensions shown in the Plans for existing facilities are in accordance with available information obtained without uncovering, measuring, or other verification.

The following addresses and telephone numbers of utility companies known or suspected of having facilities within the project limits are supplied for the Contractor's convenience.

UTILITY CONTACTS

Puget Sound Energy (Power)

Attn: Jason Airey
3130 S 38th St
Tacoma, WA 98409

Lumen

Attn: Lara Lant
1208 NE 64th St
Seattle, WA 98115

CITY OF FEDERAL WAY

SP-25

**ON-CALL SIDEWALK AND CURB
REPLACEMENT
PROJECT #101-2023A**

Telephone: (206) 348-9637

Lara.Lant@Lumen.com
Telephone: (206) 765-9885

Puget Sound Energy (Gas)

Attn: Katie Dierick
Katie.Dierick@pse.com
Cell: (253) 268-6331

Comcast

Attn: Kyle Kinney
410 Valley Ave NW
Puyallup, WA 98371
Kyle_Kinney@comcast.com
Telephone: (253) 293-3838

Lakehaven Water & Sewer District

Attn: Naveen Chandra, P.E.
31623 1st Avenue S
Federal Way, WA 98063-4249
NChandra@lakehaven.org
Telephone: (253) 946-5440
Cell: (206) 966-8185

AT&T

Attn: Steve Duppenhaler
11241 Willows Rd NE, #130
Redmond, WA 98052
Telephone: (425)286-3822

Zayo

Attn: Jason Tesdal
4905 Pacific Hwy E, Suite 4
Fife, WA 98424
Jason.Tesdal@zayo.com
Telephone: (253) 221-7585

City of FW IT Dept (City Fiber)

Attn: Thomas Fichtner
33325 8th Ave S
Federal Way, WA 98003
Telephone: (253) 835-2547

King Co. Traffic (Signals & Lighting)

Attn: Mark Parrett
155 Monroe Ave NE
Renton, WA 98056
Telephone: (206) 296-8153

ADDITIONAL CONTACTS

King County Metro Transit

81270 6th Ave S, Bldg 2
Seattle, WA 98134
Telephone: (206) 684-2785

South King Fire & Rescue

31617 1st Ave S
Federal Way, WA 98003
Telephone: (253) 946-7253

City of Federal Way Police

33325 8th Ave S
Federal Way, WA 98003
Telephone: (253) 835-6701
(for officer traffic control scheduling)
Telephone: (253) 835-6767
(for traffic / road closure issues)

Federal Way School District

Attn: Transportation Department
1211 S. 332nd St
Federal Way, WA 98003
Telephone: (253) 945-5960

1-07.18 Public Liability and Property Damage Insurance

Delete this section in its entirety, and replace it with the following:

1-07.18 Insurance

CITY OF FEDERAL WAY

**ON-CALL SIDEWALK AND CURB
REPLACEMENT
PROJECT #101-2023A**

SP-26

(December 30, 2022 APWA GSP)

1-07.18(1) General Requirements

- A. The Contractor shall procure and maintain the insurance described in all subsections of section 1-07.18 of these Special Provisions, from insurers with a current A. M. Best rating of not less than A-: VII and licensed to do business in the State of Washington. The Contracting Agency reserves the right to approve or reject the insurance provided, based on the insurer's financial condition.
- B. The Contractor shall keep this insurance in force without interruption from the commencement of the Contractor's Work through the term of the Contract and for thirty (30) days after the Physical Completion date, unless otherwise indicated below.
- C. If any insurance policy is written on a claims-made form, its retroactive date, and that of all subsequent renewals, shall be no later than the effective date of this Contract. The policy shall state that coverage is claims made, and state the retroactive date. Claims-made form coverage shall be maintained by the Contractor for a minimum of 36 months following the Completion Date or earlier termination of this Contract, and the Contractor shall annually provide the Contracting Agency with proof of renewal. If renewal of the claims made form of coverage becomes unavailable, or economically prohibitive, the Contractor shall purchase an extended reporting period ("tail") or execute another form of guarantee acceptable to the Contracting Agency to assure financial responsibility for liability for services performed.
- D. The Contractor's Automobile Liability, Commercial General Liability and Excess or Umbrella Liability insurance policies shall be primary and non-contributory insurance as respects the Contracting Agency's insurance, self-insurance, or self-insured pool coverage. Any insurance, self-insurance, or self-insured pool coverage maintained by the Contracting Agency shall be excess of the Contractor's insurance and shall not contribute with it.
- E. The Contractor shall provide the Contracting Agency and all additional insureds with written notice of any policy cancellation, within two business days of their receipt of such notice.
- F. The Contractor shall not begin work under the Contract until the required insurance has been obtained and approved by the Contracting Agency
- G. Failure on the part of the Contractor to maintain the insurance as required shall constitute a material breach of contract, upon which the Contracting Agency may, after giving five business days' notice to the Contractor to correct the breach, immediately terminate the Contract or, at its discretion, procure or renew such insurance and pay any and all premiums in connection therewith, with any sums so expended to be repaid to the Contracting Agency on demand, or at the sole discretion of the Contracting Agency, offset against funds due the Contractor from the Contracting Agency.
- H. All costs for insurance shall be incidental to and included in the unit or lump sum prices of the Contract and no additional payment will be made.

(March 9, 2023 WSDOT GSP)

CITY OF FEDERAL WAY

**ON-CALL SIDEWALK AND CURB
REPLACEMENT
PROJECT #101-2023A**

SP-27

Section 1-07.18(1) is supplemented with the following:

Under no circumstances shall a wrap up policy be obtained, for either initiating or maintaining coverage, to satisfy insurance requirements for any policy required under this section. A wrap up policy is defined as an insurance agreement or arrangement under which all the parties working on a specified or designated project are insured under one policy for liability arising out of that specified or designated project.

(December 30, 2022 APWA GSP, cont.)

1-07.18(2) Additional Insured

All insurance policies, with the exception of Workers Compensation, and of Professional Liability and Builder's Risk (if required by this Contract) shall name the following listed entities as additional insured(s) using the forms or endorsements required herein:

- The Contracting Agency and its officers, elected officials, employees, agents, and volunteers.
- The Consultant that completed the preparation of the engineering design and project plans, and its officers, employees, agents, and subconsultants.
- Consultants hired by the Contracting Agency for design, construction support, or materials testing.

The above-listed entities shall be additional insured(s) for the full available limits of liability maintained by the Contractor, irrespective of whether such limits maintained by the Contractor are greater than those required by this Contract, and irrespective of whether the Certificate of Insurance provided by the Contractor pursuant to 1-07.18(4) describes limits lower than those maintained by the Contractor.

For Commercial General Liability insurance coverage, the required additional insured endorsements shall be at least as broad as ISO forms CG 20 10 10 01 for ongoing operations and CG 20 37 10 01 for completed operations.

1-07.18(3) Subcontractors

The Contractor shall cause each subcontractor of every tier to provide insurance coverage that complies with all applicable requirements of the Contractor-provided insurance as set forth herein, except the Contractor shall have sole responsibility for determining the limits of coverage required to be obtained by subcontractors.

The Contractor shall ensure that all subcontractors of every tier add all entities listed in 1-07.18(2) as additional insureds, and provide proof of such on the policies as required by that section as detailed in 1-07.18(2) using an endorsement as least as broad as ISO CG 20 10 10 01 for ongoing operations and CG 20 37 10 01 for completed operations.

Upon request by the Contracting Agency, the Contractor shall forward to the Contracting Agency evidence of insurance and copies of the additional insured endorsements of each subcontractor of every tier as required in 1-07.18(4) Verification of Coverage.

1-07.18(4) Verification of Coverage

The Contractor shall deliver to the Contracting Agency a Certificate(s) of Insurance and endorsements for each policy of insurance meeting the requirements set forth herein when the Contractor delivers the signed Contract for the work. Failure of Contracting Agency to demand such verification of coverage with these insurance requirements or failure of

Contracting Agency to identify a deficiency from the insurance documentation provided shall not be construed as a waiver of Contractor's obligation to maintain such insurance.

Verification of coverage shall include:

1. An ACORD certificate or a form determined by the Contracting Agency to be equivalent.
2. Copies of all endorsements naming Contracting Agency and all other entities listed in 1-07.18(2) as additional insured(s), showing the policy number. The Contractor may submit a copy of any blanket additional insured clause from its policies instead of a separate endorsement.
3. Any other amendatory endorsements to show the coverage required herein.
4. A notation of coverage enhancements on the Certificate of Insurance shall not satisfy these requirements – actual endorsements must be submitted.

Upon request by the Contracting Agency, the Contractor shall forward to the Contracting Agency a full and certified copy of the insurance policy(s). If Builders Risk insurance is required on this Project, a full and certified copy of that policy is required when the Contractor delivers the signed Contract for the work.

1-07.18(5) Coverages and Limits

The insurance shall provide the minimum coverages and limits set forth below. Contractor's maintenance of insurance, its scope of coverage, and limits as required herein shall not be construed to limit the liability of the Contractor to the coverage provided by such insurance, or otherwise limit the Contracting Agency's recourse to any remedy available at law or in equity.

All deductibles and self-insured retentions must be disclosed and are subject to approval by the Contracting Agency. The cost of any claim payments falling within the deductible or self-insured retention shall be the responsibility of the Contractor. In the event an additional insured incurs a liability subject to any policy's deductibles or self-insured retention, said deductibles or self-insured retention shall be the responsibility of the Contractor.

1-07.18(5)A Commercial General Liability

Commercial General Liability insurance shall be written on coverage forms at least as broad as ISO occurrence form CG 00 01, including but not limited to liability arising from premises, operations, stop gap liability, independent contractors, products-completed operations, personal and advertising injury, and liability assumed under an insured contract. There shall be no exclusion for liability arising from explosion, collapse or underground property damage.

The Commercial General Liability insurance shall be endorsed to provide a per project general aggregate limit, using ISO form CG 25 03 05 09 or an equivalent endorsement.

Contractor shall maintain Commercial General Liability Insurance arising out of the Contractor's completed operations for at least three years following Substantial Completion of the Work.

Such policy must provide the following minimum limits:

\$1,000,000	Each Occurrence
\$2,000,000	General Aggregate
\$2,000,000	Products & Completed Operations Aggregate
\$1,000,000	Personal & Advertising Injury each offense
\$1,000,000	Stop Gap / Employers' Liability each Accident

(August 27, 2021 CFW GSP)

The Commercial General Liability minimum coverage limit, per each occurrence shown in Section 1-07.18(5)A of the APWA Special Provision included herein is modified as follows:

The minimum limit for Commercial General Liability Insurance, per each occurrence shall be \$2,000,000.

(December 30, 2022 APWA GSP, cont.)

1-07.18(5)B Automobile Liability

Automobile Liability shall cover owned, non-owned, hired, and leased vehicles; and shall be written on a coverage form at least as broad as ISO form CA 00 01. If the work involves the transport of pollutants, the automobile liability policy shall include MCS 90 and CA 99 48 endorsements.

Such policy must provide the following minimum limit:

\$1,000,000	Combined single limit each accident
-------------	-------------------------------------

1-07.18(5)C Workers' Compensation

The Contractor shall comply with Workers' Compensation coverage as required by the Industrial Insurance laws of the State of Washington.

1-07.18(5)D Excess or Umbrella Liability

(January 4, 2016 APWA GSP)

The Contractor shall provide Excess or Umbrella Liability insurance with limits of not less than \$3,000,000 each occurrence and annual aggregate. This excess or umbrella liability coverage shall be excess over and as least as broad in coverage as the Contractor's Commercial General and Auto Liability insurance.

All entities listed under 1-07.18(2) of these Special Provisions shall be named as additional insureds on the Contractor's Excess or Umbrella Liability insurance policy.

This requirement may be satisfied instead through the Contractor's primary Commercial General and Automobile Liability coverages, or any combination thereof that achieves the overall required limits of insurance.

1-07.18(5)J Pollution Liability

(January 4, 2016 APWA GSP)

The Contractor shall provide a Contractors Pollution Liability policy, providing coverage for claims involving bodily injury, property damage (including loss of use of tangible property that has not been physically injured), cleanup costs, remediation, disposal or other handling of pollutants, including costs and expenses incurred in the investigation, defense, or settlement of claims, arising out of any one or more of the following:

1. Contractor's operations related to this project.

2. Remediation, abatement, repair, maintenance or other work with lead-based paint or materials containing asbestos.
3. Transportation of hazardous materials away from any site related to this project.

All entities listed under 1-07.18(2) of these Special Provisions shall be named by endorsement as additional insureds on the Contractors Pollution Liability insurance policy.

Such Pollution Liability policy shall provide the following minimum limits:
\$2,000,000 each loss and annual aggregate

1-07.23 Public Convenience and Safety

(February 6, 2023 WSDOT GSP, OPTION 5)

Section 1-07.23(1) is supplemented with the following:

Lane, ramp, shoulder, and roadway closures are subject to the following restrictions:

- The Contractor shall, at all times throughout the project, conduct the work in such a manner as will obstruct and inconvenience vehicular and pedestrian traffic as little as possible. The streets, sidewalks and private driveways shall be kept open by the Contractor except for the brief periods when actual work is being done. The Contractor shall conduct his operations so as to have under construction no greater length or amount of work than he can prosecute vigorously and he shall not open up sections of the work and leave them in an unfinished condition.
- The Contractor shall provide flaggers, signs, and other traffic control devices. The Contractor shall erect and maintain all construction signs, warning signs, detour signs, and other traffic control devices necessary to warn and protect the public at all times from injury or damage as a result of the Contractor's operations which may occur on highways, roads, streets, sidewalks, or paths. No work shall be done on or adjacent to any traveled way until all necessary signs and traffic control devices are in place.
- All signs and traffic control devices for the permitted closures shall only be installed during the specified hours. Construction signs, if placed earlier than the specified hours of closure, shall be turned or covered so as not to be visible to motorists
- The Contractor shall keep all pedestrian routes & access points (including, but not limited to, sidewalks, and crosswalks when located within the project limits) open and clear at all times unless permitted otherwise by the Engineer in an approved traffic control plan. An ADA accessible route must be provided through the project site at all times.
- Pedestrians must have access to pedestrian push buttons at all times.

- Lane closures shall not impact business access. All businesses shall remain accessible by vehicles and pedestrian during business hours.
- Lane closures shall not restrict vehicular access for buses through the project site. Bus stops shall remain ADA accessible to pedestrians at all times throughout the project.
- The Contractor shall be responsible for notifying all affected property owners and tenants prior to commencing the barricading of streets, alleys, sidewalks and driveways. Notifications should be at least 48 hours in advance of closures, if possible.
- No paving or planing (milling) shall occur in residential areas during refuse, recycle, and yard waste collection days. Collection schedules are available at www.cityoffederalway.com/publicworks/recycling.
- For approved night work, it shall be the Contractor's responsibility to obtain any required noise variance or exemption for such work.
- For approved night work, the Contractor shall, at no additional cost to the City, make all arrangements for operations during hours of darkness. Flagger stations shall be illuminated using a minimum 150-watt floodlight. Lighting used for nighttime work shall, whenever possible, be directed away from or shielded from residences and oncoming traffic. Signs and barricades shall be supplemented by Type C steady burn lights to delineate edge of roadway during the hours of darkness.
- The Contractor may, if shown on a traffic control plan approved by the Engineer, momentarily interrupt continuous two-way traffic to allow one-way traffic (alternating directions / flagger controlled). Such interruptions shall utilize qualified flaggers placed in strategic locations to insure the public safety and minimize driver confusion.
- For projects with bid schedules located in multiple locations throughout the City, the Contractor shall not have personnel or subcontractors working on-site at more than two schedules at any given time.
- Lane closures on arterial streets may only occur between the hours of 8:00AM and 3:00PM.
- When school is in session, no lane closures may occur during student drop-off and pick-up times. Additionally, driveway ingress and egress shall be unobstructed during these times. Daily bell schedules, as well as calendars which reflect no-school days, early release days, and half-days are also available on fwps.org.

- Student Drop-Off (typically in morning): No lane closures beginning 20 minutes prior to school start time until 10 minutes after school start time.
- Student Pick-Up (typically in afternoon): No lane closures beginning 20 minutes prior to school end time until 20 minutes after school end time.

If the Engineer determines the permitted closure hours adversely affect traffic, the Engineer may adjust the hours accordingly. The Engineer will notify the Contractor in writing of any change in the closure hours. Exceptions to these restrictions are listed below and when applicable take precedence over closures listed above. The Engineer may also consider on a case-by-case basis additional exceptions following a written request by the Contractor.

Lane, ramp, shoulder, and roadway closures are not allowed on any of the following:

1. A holiday,
2. A holiday weekend; holidays that occur on Friday, Saturday, Sunday or Monday are considered a holiday weekend. A holiday weekend includes Saturday, Sunday, and the holiday.
3. After 12:00 PM (noon) on the day prior to a holiday or holiday weekend, and
4. Before 7:00 AM on the day after the holiday or holiday weekend.
5. Within the City Center zone from the Friday after Thanksgiving Day (“Black Friday”) until the first City recognized business day of the following year without written approval by the Engineer. The boundaries of the City Center zone are identified in the City of Federal Way Comprehensive Plan. In general, it is the area located within the following boundaries:
 - Northern boundary: S 312th Street
 - Southern boundary: S 324th Street
 - Eastern boundary: Interstate 5
 - Western boundary: 14th Ave S (future extension) / Federal Way 320th Library / 11th PI S

Traffic Delays

When Automated Flagger Assistance Devices (AFADs) or flaggers are used to control traffic, traffic shall not be stopped for more than two minutes at any time. All traffic congestion shall be allowed to clear before traffic is delayed again.

If the delay becomes greater than two minutes, the Contractor shall immediately begin to take action to cease the operations that are causing the delays. If the two minute delay limit has been exceeded, as determined by the Engineer, the Contractor shall provide to the Engineer, a written proposal to revise his work

operations to meet the two minute limit. This proposal shall be accepted by the Engineer prior to resuming any work requiring traffic control.

There shall be no delay to medical, fire, or other emergency vehicles. The Contractor shall alert all flaggers and personnel of this requirement.

General Restrictions

Construction vehicles using a closed traffic lane shall travel only in the normal direction of traffic flow unless expressly allowed in an accepted traffic control plan. Construction vehicles shall be equipped with flashing or rotating amber lights.

No two consecutive on-ramps, off-ramps, or intersections shall be closed at the same time and only one ramp at an interchange shall be closed, unless specifically shown in the Plans.

Roads or ramps that are designated as part of a detour shall not be closed or restricted during the implementation of that detour, unless specifically shown in the Plans.

Controlled Access

No special access or egress shall be allowed by the Contractor other than normal legal movements or as shown in the Plans.

Contractor's vehicles of 10,000 GVW or greater shall not exit or enter a lane open to public traffic except as follows:

Egress and ingress shall only occur during the hours of allowable lane closures, and:

1. For exiting an open lane of traffic, by decelerating in a lane that is closed during the allowable hours for lane closures.
2. For entering an open lane of traffic, by accelerating in a closed lane during the allowable hours for lane closures.

Traffic control vehicles are excluded from the gross vehicle weight requirement. If placing construction signs will restrict traveled lanes, then the work will be permitted during the hours of allowable lane closures.

Advance Notification

The Contractor shall notify the Engineer in writing of any traffic impacts related to lane closure, shoulder closure, sidewalk closure, or any combination for the week by 12:00 p.m. (noon) Wednesday the week prior to the stated impacts.

The Contractor shall notify the Engineer in writing ten working days in advance of any traffic impacts related to full roadway closure, ramp closure, or both.

The Contractor shall notify the Engineer in writing of any changes to the stated traffic impacts a minimum of 48 hours prior to the traffic impacts.

1-07.24 Rights of Way
(July 23, 2015 APWA GSP)

Delete this section and replace it with the following:

Street Right of Way lines, limits of easements, and limits of construction permits are indicated in the Plans. The Contractor's construction activities shall be confined within these limits, unless arrangements for use of private property are made.

Generally, the Contracting Agency will have obtained, prior to bid opening, all rights of way and easements, both permanent and temporary, necessary for carrying out the work. Exceptions to this are noted in the Bid Documents or will be brought to the Contractor's attention by a duly issued Addendum.

Whenever any of the work is accomplished on or through property other than public Right of Way, the Contractor shall meet and fulfill all covenants and stipulations of any easement agreement obtained by the Contracting Agency from the owner of the private property. Copies of the easement agreements may be included in the Contract Provisions or made available to the Contractor as soon as practical after they have been obtained by the Engineer.

Whenever easements or rights of entry have not been acquired prior to advertising, these areas are so noted in the Plans. The Contractor shall not proceed with any portion of the work in areas where right of way, easements or rights of entry have not been acquired until the Engineer certifies to the Contractor that the right of way or easement is available or that the right of entry has been received. If the Contractor is delayed due to acts of omission on the part of the Contracting Agency in obtaining easements, rights of entry or right of way, the Contractor will be entitled to an extension of time. The Contractor agrees that such delay shall not be a breach of contract.

Each property owner shall be given 48 hours notice prior to entry by the Contractor. This includes entry onto easements and private property where private improvements must be adjusted.

The Contractor shall be responsible for providing, without expense or liability to the Contracting Agency, any additional land and access thereto that the Contractor may desire for temporary construction facilities, storage of materials, or other Contractor needs. However, before using any private property, whether adjoining the work or not, the Contractor shall file with the Engineer a written permission of the private property owner, and, upon vacating the premises, a written release from the property owner of each property disturbed or otherwise interfered with by reasons of construction pursued under this contract. The statement shall be signed by the private property owner, or proper authority acting for the owner of the private property affected, stating that permission has been granted to use the property and all necessary permits have been obtained or, in the case of a release, that the restoration of the property has been satisfactorily accomplished. The statement shall include the parcel number, address, and date of signature. Written releases must be filed with the Engineer before the Completion Date will be established.

(April 12, 2018 CFW GSP)

Section 1-07.24 is supplemented with the following::

The Contractor shall be responsible to abide by the right-of-entry agreements with adjacent property owners that have been obtained (if any) by the City for this project.

CITY OF FEDERAL WAY

**ON-CALL SIDEWALK AND CURB
REPLACEMENT
PROJECT #101-2023A**

SP-35

Please note these agreements may be included as an appendix or will be made available upon request of the Contractor.

Right-of-entries on adjacent private property have been secured for purposes such as: construction of driveways, slope restoration, drainage, utilities, irrigation, and/or property restoration. The Contractor is expressly forbidden from using right-of-entry areas for vehicle or equipment storage or material stockpiling without first receiving written approval from the property owner. A copy of the written approval shall be provided to the Engineer before the Contractor stores any equipment or materials. Written permission from property owners does not relieve the Contractor of their obligation to receive permission from the City Community Development Department for the use of sites as staging areas, if required.

Right-of-entry agreements may include responsibilities for the Contractor, such as: listing property owners as additional insured; providing advance notice to certain representatives; or daily site cleanup requirements. These responsibilities are listed as examples only and the right-of-entry documents should be reviewed by the Contractor to determine all necessary requirements.

Owners of certain properties have placed limitations on their right-of-entries as described below:

- TBD

1-07.28 Communication with Businesses and Property Owners

(April 12, 2018 CFW GSP)

Section 1-07.28 is added:

The Contractor will be responsible for communicating all work activities with the property owners / tenants that are located adjacent to the project. The Contractor, along with the City's inspector & project engineer, shall have one formal meeting (door-to-door project walk-through) with the property owners/tenants prior to the start of construction. It will be the Contractor's responsibility to initiate and set up the meeting.

Thereafter, the Contractor shall keep the property owners / tenants informed of their general work locations and upcoming activities by distributing a monthly status/schedule memo to the businesses. The memo shall be approved by the City's Project Engineer prior to distribution.

1-07.29 Coordination with Transit Agencies

(December 1, 2021 CFW GSP)

Section 1-07.29 is added:

The Contractor is required to coordinate with impacted transit agencies. King County Metro and/or Pierce Transit personnel will remove and reinstall all existing bus stop signs and supports within the project limits. A copy of all communications between the contractor and transit agencies shall be forwarded to the City of Federal Way.

King County Metro: King County should be notified in writing at construction.coord@kingcounty.gov a minimum of five business days prior to starting any work impacting bus stops, a temporary lane or road closure. Work requiring removing a bus shelter or sign requires notification in writing a minimum of 30 business days.

Pierce Transit: Pierce Transit should be notified at (253)581-8130 to coordinate.

1-08 PROSECUTION AND PROGRESS

Add the following new section:

1-08.0 Preliminary Matters ***(May 25, 2006 APWA GSP)***

1-08.0(1) Preconstruction Conference ***(October 10, 2008 APWA GSP)***

Prior to the Contractor beginning the work, a preconstruction conference will be held between the Contractor, the Engineer, and such other interested parties as may be invited. The purpose of the preconstruction conference will be:

1. To review the initial progress schedule;
2. To establish a working understanding among the various parties associated or affected by the work;
3. To establish and review procedures for progress payment, notifications, approvals, submittals, etc.;
4. To establish normal working hours for the work;
5. To review safety standards and traffic control; and
6. To discuss such other related items as may be pertinent to the work.

The Contractor shall prepare and submit at the preconstruction meeting the following:

1. A breakdown of all lump sum items;
2. A preliminary schedule of working drawing submittals; and
3. A list of material sources for approval if applicable.

1-08.0(2) Hours of Work ***(December 8, 2014 APWA GSP)***

Add the following new section:

Except in the case of emergency or unless otherwise approved by the Engineer, the normal working hours for the Contract shall be any consecutive 8-hour period between 7:00 a.m. and 6:00 p.m. Monday through Friday, exclusive of a lunch break. If the Contractor desires different than the normal working hours stated above, the request must be submitted in writing prior to the preconstruction conference, subject to the provisions below. The working hours for the Contract shall be established at or prior to the preconstruction conference.

All working hours and days are also subject to local permit and ordinance conditions (such as noise ordinances).

If the Contractor wishes to deviate from the established working hours, the Contractor shall submit a written request to the Engineer for consideration. This

request shall state what hours are being requested, and why. Requests shall be submitted for review no later than noon two working days prior to the day(s) the Contractor is requesting to change the hours.

If the Contracting Agency approves such a deviation, such approval may be subject to certain other conditions, which will be detailed in writing. For example:

1. On non-Federal aid projects, requiring the Contractor to reimburse the Contracting Agency for the costs in excess of straight-time costs for Contracting Agency representatives who worked during such times. (The Engineer may require designated representatives to be present during the work. Representatives who may be deemed necessary by the Engineer include, but are not limited to: survey crews; personnel from the Contracting Agency's material testing lab; inspectors; and other Contracting Agency employees or third party consultants when, in the opinion of the Engineer, such work necessitates their presence.)
2. Considering the work performed on Saturdays, Sundays, and holidays as working days with regard to the contract time.
3. Considering multiple work shifts as multiple working days with respect to contract time even though the multiple shifts occur in a single 24-hour period.
4. If a 4-10 work schedule is requested and approved the non-working day for the week will be charged as a working day.
5. If Davis Bacon wage rates apply to this Contract, all requirements must be met and recorded properly on certified payroll.

(December 1, 2021 CFW GSP)

Add the following new section:

The Contractor may request extended work hours on days when paving operations are occurring. Work hours may be modified to 7:00 a.m. to 5:30 p.m. on paving days if the Engineer determines that the benefits of extended working hours will minimize the overall impacts to traffic. Extended work hours for paving will require PCMS boards to be placed a minimum of 2 business days prior to the paving day. Payment for PCMS boards shall be considered incidental to the Contractor's operations, unless there is a specific bid item for PCMS boards.

1-08.1 Subcontracting

1-08.3 Progress Schedule

1-08.3(1) General Requirements

(October 3, 2022 WSDOT GSP, OPTION 2)

Section 1-08.3(1) is supplemented with the following:

In addition to information required in Items 1 through 6, the Progress Schedule shall include the following milestones and/or activities:

7. Materials requiring long procurement or fabrication periods, such as signal or light poles, structural elements, or mechanical items.

1-08.3(2) A Type A Progress Schedule
(December 30, 2022 APWA GSP)

Revise this section to read:

The Contractor shall submit 2 copies of a Type A Progress Schedule no later than at the preconstruction conference, or some other mutually agreed upon submittal time. The schedule may be a critical path method (CPM) schedule, bar chart, or other standard schedule format. Regardless of which format used, the schedule shall identify the critical path. The Engineer will evaluate the Type A Progress Schedule and approve or return the schedule for corrections within 15 calendar days of receiving the submittal.

1-08.4 Prosecution of Work

Delete this section and replace it with the following:

1-08.4 Notice to Proceed and Prosecution of Work
(July 23, 2015 APWA GSP)

Notice to Proceed will be given after the contract has been executed and the contract bond and evidence of insurance have been approved and filed by the Contracting Agency. The Contractor shall not commence with the work until the Notice to Proceed has been given by the Engineer. The Contractor shall commence construction activities on the project site within ten days of the Notice to Proceed Date, unless otherwise approved in writing. The Contractor shall diligently pursue the work to the physical completion date within the time specified in the contract. Voluntary shutdown or slowing of operations by the Contractor shall not relieve the Contractor of the responsibility to complete the work within the time(s) specified in the contract.

When shown in the Plans, the first order of work shall be the installation of high visibility fencing to delineate all areas for protection or restoration, as described in the Contract. Installation of high visibility fencing adjacent to the roadway shall occur after the placement of all necessary signs and traffic control devices in accordance with 1-10.1(2). Upon construction of the fencing, the Contractor shall request the Engineer to inspect the fence. No other work shall be performed on the site until the Contracting Agency has accepted the installation of high visibility fencing, as described in the Contract.

(December 1, 2021 CFW GSP)

Section 1-08.4 is supplemented with the following.

The Contractor shall provide adequate equipment and forces to carry out the construction schedule to completion of the contract by the date specified.

1-08.5 Time for Completion

(December 30, 2022 APWA GSP, OPTION A)

Revise the third and fourth paragraphs to read:

Contract time shall begin on the first working day following the Notice to Proceed Date.

Each working day shall be charged to the contract as it occurs, until the contract work is physically complete. If substantial completion has been granted and all the authorized working days have been used, charging of working days will cease. Each week the Engineer will provide the Contractor a statement that shows the number of working days: (1) charged to the contract the week before; (2) specified for the physical completion of the contract; and (3) remaining for the physical completion of the contract. The statement

will also show the nonworking days and any partial or whole day the Engineer declares as unworkable. The statement will be identified as a Written Determination by the Engineer. If the Contractor does not agree with the Written Determination of working days, the Contractor shall pursue the protest procedures in accordance with Section 1-04.5. By failing to follow the procedures of Section 1-04.5, the Contractor shall be deemed as having accepted the statement as correct. If the Contractor is approved to work 10 hours a day and 4 days a week (a 4-10 schedule) and the fifth day of the week in which a 4-10 shift is worked would ordinarily be charged as a working day then the fifth day of that week will be charged as a working day whether or not the Contractor works on that day.

Revise the sixth paragraph to read:

The Engineer will give the Contractor written notice of the completion date of the contract after all the Contractor's obligations under the contract have been performed by the Contractor. The following events must occur before the Completion Date can be established:

1. The physical work on the project must be complete; and
2. The Contractor must furnish all documentation required by the contract and required by law, to allow the Contracting Agency to process final acceptance of the contract. The following documents must be received by the Project Engineer prior to establishing a completion date:
 - a. Certified Payrolls (per Section 1-07.9(5)).
 - b. Material Acceptance Certification Documents
 - c. Monthly Reports of Amounts Credited as DBE Participation, as required by the Contract Provisions.
 - d. Final Contract Voucher Certification
 - e. Copies of the approved "Affidavit of Prevailing Wages Paid" for the Contractor and all Subcontractors
 - f. A copy of the Notice of Termination sent to the Washington State Department of Ecology (Ecology); the elapse of 30 calendar days from the date of receipt of the Notice of Termination by Ecology; and no rejection of the Notice of Termination by Ecology. This requirement will not apply if the Construction Stormwater General Permit is transferred back to the Contracting Agency in accordance with Section 8-01.3(16).
 - g. Property owner releases per Section 1-07.24

(Project Specific Special Provision)

Section 1-08.5 is supplemented with the following:

Each Task Order shall be completed within a negotiated amount of working days. In no case shall it take longer than five (5) working days to replace removed sidewalk or curb.

1-08.9 Liquidated Damages

(Project Specific Special Provision)

Delete Section 1-08.9.

CITY OF FEDERAL WAY

SP-40

ON-CALL SIDEWALK AND CURB
REPLACEMENT
PROJECT #101-2023A

1-09 MEASUREMENT AND PAYMENT

1-09.2(1) General Requirements for Weighing Equipment ***(December 30, 2022 APWA GSP, OPTION 2)***

Revise item 4 of the fifth paragraph to read:

4. Test results and scale weight records for each day's hauling operations are provided to the Engineer daily. Reporting shall utilize WSDOT form 422-027, Scaleman's Daily Report, unless the printed ticket contains the same information that is on the Scaleman's Daily Report Form. The scale operator must provide AM and/or PM tare weights for each truck on the printed ticket.

1-09.2(1)A1 Equipment ***(March 9, 2023 WSDOT GSP)***

Item number 1 in the first paragraph of Section 1-09.2(1)A1 is revised to read:

1. The ETS shall generate an E-ticket in PDF format meeting the requirements of 1-09.2(1)A2. The information shall be immediately uploaded to a designated site so the information can be accessed by the Inspector located at the material delivery site.

1-09.2(5) Measurement ***(December 30, 2022 APWA GSP)***

Revise the first paragraph to read:

Scale Verification Checks – At the Engineer's discretion, the Engineer may perform verification checks on the accuracy of each batch, hopper, or platform scale used in weighing contract items of Work.

1-09.6 Force Account ***(December 30, 2022 APWA GSP)***

Supplement this section with the following:

The Contracting Agency has estimated and included in the Proposal, dollar amounts for all items to be paid per force account, only to provide a common proposal for Bidders. All such dollar amounts are to become a part of Contractor's total bid. However, the Contracting Agency does not warrant expressly or by implication, that the actual amount of work will correspond with those estimates. Payment will be made on the basis of the amount of work actually authorized by the Engineer.

1-09.7 Mobilization ***(Project Specific Special Provision)***

Paragraphs 5-9 of Section 1-09.7 are deleted.

Supplement Section 1-09.7 with the following:

Obtaining a site for the Contractor's mobilization, field office(s), storage of materials, access and personnel parking spaces, and other general operations shall be the responsibility of the Contractor. The Contractor will be responsible for maintaining these spaces in a safe and orderly condition throughout the duration of the project. The Contractor shall provide the City with a copy of agreement(s) with property owner. All costs associated with securing sites shall be included in the other bid items on the project and no other compensation will be made.

Costs for the lump sum item of Mobilization shall be equal to 10% of the Task Order costs (not including mobilization).

1-09.9 Payments

(December 30, 2022 APWA GSP)

Section 1-09.9 is revised to read:

The basis of payment will be the actual quantities of Work performed according to the Contract and as specified for payment.

The Contractor shall submit a breakdown of the cost of lump sum bid items at the Preconstruction Conference, to enable the Project Engineer to determine the Work performed on a monthly basis. A breakdown is not required for lump sum items that include a basis for incremental payments as part of the respective Specification. Absent a lump sum breakdown, the Project Engineer will make a determination based on information available. The Project Engineer's determination of the cost of work shall be final.

Progress payments for completed work and material on hand will be based upon progress estimates prepared by the Engineer. A progress estimate cutoff date will be established at the preconstruction conference.

The initial progress estimate will be made not later than 30 days after the Contractor commences the work, and successive progress estimates will be made every month thereafter until the Completion Date. Progress estimates made during progress of the work are tentative, and made only for the purpose of determining progress payments. The progress estimates are subject to change at any time prior to the calculation of the final payment.

The value of the progress estimate will be the sum of the following:

1. Unit Price Items in the Bid Form — the approximate quantity of acceptable units of work completed multiplied by the unit price.
2. Lump Sum Items in the Bid Form — based on the approved Contractor's lump sum breakdown for that item, or absent such a breakdown, based on the Engineer's determination.
3. Materials on Hand — 100 percent of invoiced cost of material delivered to Job site or other storage area approved by the Engineer.
4. Change Orders — entitlement for approved extra cost or completed extra work as determined by the Engineer.

Progress payments will be made in accordance with the progress estimate less:

1. Retainage per Section 1-09.9(1), on non FHWA-funded projects;
2. The amount of progress payments previously made; and
3. Funds withheld by the Contracting Agency for disbursement in accordance with the Contract Documents.

Progress payments for work performed shall not be evidence of acceptable performance or an admission by the Contracting Agency that any work has been satisfactorily completed. The determination of payments under the contract will be final in accordance with Section 1-05.1.

Failure to perform obligations under the Contract by the Contractor may be decreed by the Contracting Agency to be adequate reason for withholding any payments until compliance is achieved.

Upon completion of all Work and after final inspection (Section 1-05.11), the amount due the Contractor under the Contract will be paid based upon the final estimate made by the Engineer and presentation of a Final Contract Voucher Certification to be signed by the Contractor. The Contractor's signature on such voucher shall be deemed a release of all claims of the Contractor unless a Certified Claim is filed in accordance with the requirements of Section 1-09.11 and is expressly excepted from the Contractor's certification on the Final Contract Voucher Certification. The date the Contracting Agency signs the Final Contract Voucher Certification constitutes the final acceptance date (Section 1-05.12).

If the Contractor fails, refuses, or is unable to sign and return the Final Contract Voucher Certification or any other documentation required for completion and final acceptance of the Contract, the Contracting Agency reserves the right to establish a Completion Date (for the purpose of meeting the requirements of RCW 60.28) and unilaterally accept the Contract. Unilateral final acceptance will occur only after the Contractor has been provided the opportunity, by written request from the Engineer, to voluntarily submit such documents. If voluntary compliance is not achieved, formal notification of the impending establishment of a Completion Date and unilateral final acceptance will be provided by email with delivery confirmation from the Contracting Agency to the Contractor, which will provide 30 calendar days for the Contractor to submit the necessary documents. The 30 calendar day period will begin on the date the email with delivery confirmation is received by the Contractor. The date the Contracting Agency unilaterally signs the Final Contract Voucher Certification shall constitute the Completion Date and the final acceptance date (Section 1-05.12). The reservation by the Contracting Agency to unilaterally accept the Contract will apply to Contracts that are Physically Completed in accordance with Section 1-08.5, or for Contracts that are terminated in accordance with Section 1-08.10. Unilateral final acceptance of the Contract by the Contracting Agency does not in any way relieve the Contractor of their responsibility to comply with all Federal, State, tribal, or local laws, ordinances, and regulations that affect the Work under the Contract.

Payment to the Contractor of partial estimates, final estimates, and retained percentages shall be subject to controlling laws.

1-09.13 Claim Resolution

1-09.13(1) General
(December 30, 2022 APWA GSP)
Revise this Section to read

Prior to seeking claims resolution through arbitration or litigation, the Contractor shall proceed in accordance with Sections 1-04.5 and 1-09.11. The provisions of Sections 1-04.5 and 1-09.11 must be complied with in full as a condition precedent to the Contractor's right to seek claim resolution through binding arbitration or litigation.

Any claims or causes of action which the Contractor has against the Contracting Agency arising from the Contract shall be resolved, as prescribed herein, through binding arbitration or litigation.

The Contractor and the Contracting Agency mutually agree that those claims or causes of action which total \$1,000,000 or less, which are not resolved by mediation, shall be resolved through litigation unless the parties mutually agree in writing to resolve the claim through binding arbitration.

The Contractor and the Contracting Agency mutually agree that those claims or causes of action in excess of \$1,000,000, which are not resolved by mediation, shall be resolved through litigation unless the parties mutually agree in writing to resolve the claim through binding arbitration.

1-09.13(3)A Arbitration General
(January 19, 2022 APWA GSP)

Revise the third paragraph to read:

The Contracting Agency and the Contractor mutually agree to be bound by the decision of the arbitrator, and judgment upon the award rendered by the arbitrator may be entered in the Superior Court of the county in which the Contracting Agency's headquarters is located, provided that where claims subject to arbitration are asserted against a county, RCW 36.01.050 shall control venue and jurisdiction of the Superior Court. The decision of the arbitrator and the specific basis for the decision shall be in writing. The arbitrator shall use the Contract as a basis for decisions.

1-09.13(4) Venue for Litigation
(December 30, 2022 APWA GSP)

Revise this section to read:

Litigation shall be brought in the Superior Court of the county in which the Contracting Agency's headquarters is located, provided that where claims are asserted against a county, RCW 36.01.050 shall control venue and jurisdiction of the Superior Court. It is mutually agreed by the parties that when litigation occurs, the Contractor shall permit the Contracting Agency to have timely access to all records deemed necessary by the Contracting Agency to assist in evaluating the claims or action.

1-10 TEMPORARY TRAFFIC CONTROL

1-10.1 General

1-10.1(2) Description
(April 12, 2018 CFW GSP)

Section 1-10.1(2) is supplemented with the following:

CITY OF FEDERAL WAY

SP-44

**ON-CALL SIDEWALK AND CURB
REPLACEMENT
PROJECT #101-2023A**

Business Open During Construction Signs

The Contractor shall provide a "Business Open During Construction" sign at every non-residential driveway approach within the project limits. Business Open During Construction Signs shall be considered Construction Signs Class A.

City of Federal Way Project Signs

City of Federal Way Project signs shall be considered Construction Signs Class A. The Contractor shall provide two (2) project signs (4' x 8') per the detail available from the City.

1-10.2 Traffic Control Management

(November 2, 2022 WSDOT GSP, OPTION 1)

Section 1-10.2 is supplemented with the following:

Work Zone Safety Contingency

Enhancements to improve the effectiveness of the accepted traffic control plans to increase the safety of the work zones shall be discussed on a weekly basis between the Contractor and the Contracting Agency. Enhancements shall be mutually agreed upon by the Contractor and Engineer prior to performing any Work to implement the enhancement.

Enhancements do not include the use of Uniformed Police Officers or WSP, address changes to the allowed work hour restrictions, or changes to the staging plans in the Contract (if applicable). If allowed by the Engineer, these items will be addressed in accordance with Section 1-04.4.

The Contractor shall be solely responsible for submitting any traffic control plan revision to implement the enhancement in accordance with Section 1-10.2(2).

1-10.2(1) General

(October 3, 2022 WSDOT GSP, OPTION 1)

Section 1-10.2(1) is supplemented with the following:

The Traffic Control Supervisor shall be certified by one of the following:

The Northwest Laborers-Employers Training Trust
27055 Ohio Ave.
Kingston, WA 98346
(360) 297-3035
<https://www.nwlett.edu>

Evergreen Safety Council
12545 135th Ave. NE
Kirkland, WA 98034-8709
1-800-521-0778
<https://www.esc.org>

The American Traffic Safety Services Association
15 Riverside Parkway, Suite 100
Fredericksburg, Virginia 22406-1022
Training Dept. Toll Free (877) 642-4637
Phone: (540) 368-1701
<https://altssa.com/training>

Integrity Safety
13912 NE 20th Ave
Vancouver, WA 98686
(360) 574-6071
<https://www.integritysafety.com>

US Safety Alliance
(904)705-5660
<https://www.ussafetyalliance.com>

K&D Services Inc.
2719 Rockefeller Ave.
Everett, WA 98201
(800) 343-4049
<https://www.kndservices.net>

1-10.2(2) Traffic Control Plans

(April 12, 2018 CFW GSP)

Section 1-10.2(2) is supplemented with the following:

The following minimum Traffic Control requirements shall be maintained during the construction of the project:

1. If the Contractor opts to utilize traffic control plans other than those provided in these Contract Documents, the Contractor shall provide traffic control plans to the City of Federal Way for review and approval a minimum of five (5) working days prior to implementation. These plans shall supplement Construction Staging Plans. The plans as provided by the Contractor shall include and not be limited to the following information:
 - Stop line locations with station and offset to verify safety of intersection turning radius for vehicles.
 - Minimum lane widths provided for vehicular travel.
 - Turn pocket length, gap, and tapers in conformance with the City of Federal Way Standard Detail DWG 3-19A.
2. Detours will not be allowed except as noted herein or Section 1-07.23(2) as amended.
3. Temporary paint striping, reflective marking tape, and/or retroreflective tubular markers shall be required for each shift of traffic control. The Contractor shall provide temporary striping, reflective marking tape, and/or reflective tubular markers as required at the direction of the Engineer.
4. The Contractor provided Traffic Control Plans shall lay out traffic control device spacing, tapers, etc., to scale, and shall contain accurate dimensions and legends and shall be signed by the preparer.

1-10.3 Traffic Control Labor, Procedures and Devices

CITY OF FEDERAL WAY

SP-46

ON-CALL SIDEWALK AND CURB
REPLACEMENT
PROJECT #101-2023A

1-10.3(1)C Signalized Intersection Traffic Control
(September 3, 2021 CFW GSP)

Section 1-10.3(1)C is a new section:

Signalized Intersection Traffic Control is required when a signal system is in flashing mode, or is not operational. Signalized intersection traffic may not be flagged with an active signal in full operation.

Placing a signalized intersection into flash mode requires an approved traffic control plan. Additionally, the days/times that a signal is placed into flash mode must be pre-approved by the City. The signal should only be switched into flash mode by the City. The type of work that requires signals to be placed into flash mode may include, but is not limited to: installation of signal poles, signal switchover, paving, striping, or excavation in the intersection.

The Contractor shall minimize the limits of the work zone area at intersections whenever possible in order to avoid having the signal be placed into flash mode.

Signalized Intersection Traffic Control Labor shall conform to WAC 468-95-302 and approved traffic control plans.

If flaggers are utilized to provide traffic control of signalized intersections:

- At least two flaggers are required to flag from the center of the intersection, in addition to a flagger controlling each leg of the intersection.

If off-duty Uniformed Police Officers are utilized to provide traffic control of signalized intersections:

- A uniformed police officer (UPO) is a sworn police officer from a local law enforcement agency or a Washington State Patrol officer.
- Off-duty uniformed police officers must have a marked police vehicle with them on the project site. Unmarked police vehicles or personal vehicles are not acceptable.
- There is currently no availability of UPO's from the City of Federal Way Police Department. Many other law enforcement agencies also have little to no availability of off-duty officers. No other agencies or private companies are authorized to perform off-duty work within the City without project-specific approval from the Federal Way Police Chief or his designee. If the Contractor is able to procure a UPO from another law enforcement agency that is acceptable to the Federal Way Chief of Police, a change order will be required to add a bid item for "Contractor Provided Off-Duty Uniformed Police Officer".

1-10.4 Measurement

1-10.4(2) Item Bids with Lump Sum for Incidentals
(August 2, 2004 WSDOT GSP, OPTION 1)

Section 1-10.4(2) is supplemented with the following:

CITY OF FEDERAL WAY

SP-47

**ON-CALL SIDEWALK AND CURB
REPLACEMENT
PROJECT #101-2023A**

The proposal does not contain the item "Project Temporary Traffic Control", lump sum. The provisions of Section 1-10.4(2) shall apply.

1-10.5 Payment

1-10.5(2) Item Bids with Lump Sum for Incidentals

(Project Specific Special Provision)

First two paragraphs of Section 1-10.5(2) are replaced with the following:

"Traffic Control Supervisor," per hour.

The per hour Contract Price for "Traffic Control Supervisor" shall be full compensation for all costs incurred by the contractor in performing the Work defined in Section 1-10.2(1)B at an agreed upon not-to-exceed quantity of hours per each Task Order.

Section 1-10.5(2) is supplemented with the following:

"Traffic Control Devices", by force account.

All costs as authorized by the Engineer will be paid for by force account as specified in Section 1-09.6. Typical items include, but are not limited to: cones, signs, and sequential arrow sign as detailed on the approved Traffic Control Plans.

For purpose of providing a common proposal for all bidders, the Contracting Agency has entered an amount for the item "Traffic Control Devices" in the Proposal to become a part of the Contractor's total bid.

The Engineer may choose to use existing bid items for the implementation of the agreed upon work.

END OF DIVISION 1

DIVISION 2 EARTHWORK

2-01 CLEARING, GRUBBING, AND ROADSIDE CLEANUP

2-01.1 Description

(March 13, 1995 WSDOT GSP, OPTION 1)

Section 2-01.1 is supplemented with the following:

Clearing and grubbing on this project shall be performed within the following limits:

Limits for clearing & grubbing shall be as shown on the plans. Clearing shall include removal of trees as noted on the plans or as directed by the Engineer to accommodate the improvements. Tree removal shall include removal of stumps and/or grinding of stumps to a depth at least two feet below finish grade.

2-01.3 Construction Requirements

2-01.3(3) Clearing Limit Fence

(April 12, 2018 CFW GSP)

Section 2-01.3(3) is a new section:

Clearing limit fence shall be 4-feet high, orange, high density polyethylene fencing with mesh openings 1½-inch by 3-inches nominal and weigh at least 7 oz. per linear foot. Either wood or steel posts shall be used. Wood posts shall have minimum dimensions of 1½ inches by 1½ inches by the minimum length of 5 feet, and shall be free of knots, splits, or gouges. Steel posts shall consist of either size No. 6 rebar or larger, ASTM A 120 steel pipe with a minimum diameter of 1 inch, U, T, L or C shape steel posts with a minimum weight of 1.35 lbs./ft. or other steel posts having equivalent strength and bending resistance to the post sizes listed. The spacing of the support posts shall be a maximum of 6½ feet.

2-01.3(4) Roadside Cleanup

(January 5, 1998 WSDOT GSP, OPTION 1)

Section 2-01.3(4) is supplemented with the following:

The Contractor shall restore, repair or correct all portions of the roadside or adjacent landscapes that were unavoidably damaged due to the performance or installation of the specified work. Unavoidable damage shall be determined only by the Engineer. All materials utilized shall be in accordance with Sections 9-14 and 9-15 and other applicable sections of the Standard Specifications or Special Provisions, whichever may apply. All work shall be performed in accordance with Sections 8-02 and 8-03 and other applicable sections of the Standard Specifications. The Contractor shall review the work with the Engineer and receive approval to proceed prior to commencing the work.

2-01.4 Measurement

(April 12, 2018 CFW GSP)

Section 2-01.4 is supplemented with the following:

“Clearing and Grubbing” will be measured on a lump sum basis. Installation, maintenance, and removal of the Clearing Limit Fence shall be included in the Clearing and Grubbing bid item.

“Roadside Cleanup”, will be measured by force account.

CITY OF FEDERAL WAY

**ON-CALL SIDEWALK AND CURB
REPLACEMENT
PROJECT #101-2023A**

SP-49

2-01.5 Payment

(April 12, 2018 CFW GSP)

Section 2-01.5 is supplemented with the following:

“Clearing and Grubbing”, lump sum.

“Roadside Cleanup”, force account.

2-02 REMOVAL OF STRUCTURES AND OBSTRUCTIONS

2-02.3 Construction Requirements

2-02.3(3) Removal of Pavement, Sidewalks, Curbs, and Gutters

(April 12, 2018 CFW GSP)

Section 2-02.3(3) is supplemented with the following:

Prior to removal of pavement, the Contractor shall make a full-depth sawcut to delineate the areas of pavement removal from those areas of pavement to remain. The Engineer shall approve the equipment and procedures used to make the full-depth sawcut. No wastewater from the sawcutting operation shall be released directly to any stream or storm sewer system.

2-02.4 Vacant

(Project Specific Special Provision)

Section 2-02.4 Vacant shall be deleted and replaced with the following:

2-02.4 Measurement

“Sawcutting” will be measured by the linear foot.

“Remove Sidewalk” will be measured per square foot.

“Remove Cement Conc. Curb and Gutter” will be measured per lineal foot.

“Remove HMA” will be measured per cubic yard of HMA not associated with curb and gutter removal.

2-02.5 Payment

(December 1, 2021 CFW GSP)

Section 2-02.5 is supplemented with the following:

Payment will be made in accordance with Section 1-04.1 for the following bid items when included in the proposal:

“Sawcutting”, per linear foot.

“Remove Sidewalk”, per square yard. Removal and disposal of sidewalk and ADA curb ramps shall be included in this bid item.

“Remove Cement Conc. Curb and Gutter” per lineal foot. Excavation and disposal of existing pavement directly in front of curb, up to two (2) feet wide, that is required for removal in accordance with City standard detail is considered incidental to this bid item.

“Remove Extruded Curb” per lineal foot.

(Project Specific Special Provision)

“Remove HMA,” per cubic yard shall be full pay for excavation, haul, and disposal of existing HMA NOT included in the HMA removal directly in front of curb and gutter as stated in this special provision.

2-03 ROADWAY EXCAVATION AND EMBANKMENT

2-03.2 Pavement Removal

(April 12, 2018 CFW GSP)

Section 2-03.2 is replaced with the following:

Where shown in the Plans or where designated by the Engineer, the Contractor shall remove asphalt, concrete, Portland cement concrete pavement, sidewalks and curbs.

Prior to removal, the Contractor shall make a full-depth sawcut to delineate the areas of pavement removal from those areas of pavement to remain. The Engineer shall approve the equipment and procedures used to make the full-depth sawcut. No wastewater from the sawcutting operation shall be released directly to any stream or storm sewer system. Alternatively, the Contractor may elect grinding for pavement removal, where appropriate.

The removed pavement shall become the property of the Contractor and shall be removed from the project. Damage caused to portions of the pavement to remain, due to the Contractor's operation, shall be repaired by the Contractor at the Contractor's expense and to the satisfaction of the Engineer.

Removal of pavement, sidewalks, curbs, and gutters throughout the project shall be measured and paid as “Roadway Excavation Incl. Haul” and no additional payment will be made.

2-03.3 Construction Requirements

Section 2-03.3(10) Selected Material

(April 12, 2018 CFW GSP)

Section 2-03.3(10) is supplemented with the following:

Selected Material when specified or required by the Engineer for use on the project shall meet the requirements of specified in Section 9-03.14(3) for Common Borrow.

Section 2-03.3(14)E Unsuitable Foundation Excavation

(August 27, 2021 CFW GSP)

Section 2-03.3(14)E is supplemented with the following:

All embankments shall be founded on dense, non-yielding granular foundation soil as approved by the engineer. Remove all organic materials and debris, trash, or

other deleterious material prior to beginning construction of new embankments.
Proof roll the foundation.

Section 2-03.3(14)G Backfilling

(April 12, 2018 CFW GSP)

Section 2-03.3(14)G is supplemented with the following:

Remove all water and non-compatible materials from excavations prior to backfilling or attempting to compact embankment soil. Place native soils or provide import Gravel Borrow as required to complete the work. Backfill all embankments in accordance with 2-03.3(14)C, Compacting Earth Embankments, Method C.

Section 2-03.3(14)N Wet Weather Earthwork

(April 12, 2018 CFW GSP)

Section 2-03.3(14)N is a new section:

Earthwork completed in wet weather or under wet conditions shall be accomplished in small sections to minimize exposure to wet weather. Each section shall be sufficiently small so that the removal of soil and placement of backfill can be accomplished on the same day. No soil shall be left un-compacted and exposed to water. Soil that is too wet for compaction shall be removed and replaced with Gravel Borrow material. Grading and earthwork should not be accomplished during periods of heavy continuous rainfall.

2-03.4 Measurement

(March 13, 1995 WSDOT GSP, OPTION 2)

Section 2-03.4 is supplemented with the following:

Only one determination of the original ground elevation will be made on this project. Measurement for roadway excavation and embankment will be based on the original ground elevations recorded previous to the award of this contract.

If discrepancies are discovered in the ground elevations, which will materially affect the quantities of earthwork, the original computations of earthwork quantities will be adjusted accordingly.

Earthwork quantities will be computed, either manually or by means of electronic data processing equipment, by use of the average end area method or by the finite element analysis method utilizing digital terrain modeling techniques.

Copies of the ground cross-section notes will be available for the bidder's inspection, before the opening of bids, at the Engineer's office and at the Region office.

Upon award of the contract, copies of the original ground cross-sections will be furnished to the successful bidder on request to the Engineer.

(April 12, 2018 CFW GSP)

Section 2-03.4 is supplemented with the following:

If the Contractor excavates outside the neat-line limits designated for "Roadway Excavation, Incl. Haul" or performs extra excavation, it shall be considered for the Contractor's benefit and shall be included in the cost of other Bid Items.

2-03.5 Payment

(April 12, 2018 CFW GSP)

Section 2-03.5 is supplemented with the following:

Payment will be made in accordance with Section 1-04.1 for the following bid items when included in the proposal:

“Roadway Excavation Incl. Haul”, per cubic yard.

(March 13, 1995 WSDOT GSP, OPTION 2)

Section 2-03.5 is supplemented with the following:

All costs in connection with the preparation of waste sites and waste deposits shall be included in the Mobilization.

END OF DIVISION 2

**DIVISION 3
AGGREGATE PRODUCTION AND ACCEPTANCE**

3-01 PRODUCTION FROM QUARRY AND PIT SITES

3-01.4 Contractor Furnished Material Sources

3-01.4(1) Acquisition and Development

(April 12, 2018 CFW GSP)

Section 3-01.4(1) is supplemented with the following:

No source has been provided for any materials necessary for the construction of these improvements.

If the source of material provided by the Contractor necessitates hauling over roads other than City streets, the Contractor shall, at his own cost and expense, make all arrangements for the use of haul routes.

END OF DIVISION 3

DIVISION 4 BASES

4-04 BALLAST AND CRUSHED SURFACING

4-04.3 Construction Requirements

4-04.3(3) Mixing

(April 12, 2018 CFW GSP)

Item 2 of Section 4-04.3(3), is replaced with the following:

2. **Road Mix Method** - The road mix method of mixing surfacing material will not be allowed.

4-04.3(4) Placing and Spreading

(April 12, 2018 CFW GSP)

Item 2 of Section 4-04(4), is replaced with the following:

2. **Road Mix Method** - The road mix method of mixing surfacing material will not be allowed.

4-04.5 Payment

(December 1, 2021 CFW GSP)

Section 4-04.5 is supplemented with the following:

The unit contract price for Ballast and Crushed Surfacing and Maintenance Rock shall also include compacting, spreading, and removing and hauling to waste when required by the Engineer.

END OF DIVISION 4

DIVISION 5 SURFACE TREATMENTS AND PAVEMENTS

5-04 HOT MIX ASPHALT ***(July 18, 2018 APWA GSP)***

Delete Section 5-04 and amendments, Hot Mix Asphalt and replace it with the following:

5-04.1 Description

This Work shall consist of providing and placing one or more layers of plant-mixed hot mix asphalt (HMA) on a prepared foundation or base in accordance with these Specifications and the lines, grades, thicknesses, and typical cross-sections shown in the Plans. The manufacture of HMA may include warm mix asphalt (WMA) processes in accordance with these Specifications. WMA processes include organic additives, chemical additives, and foaming.

HMA shall be composed of asphalt binder and mineral materials as may be required, mixed in the proportions specified to provide a homogeneous, stable, and workable mixture.

5-04.2 Materials

Materials shall meet the requirements of the following sections:

Asphalt Binder	9-02.1(4)
Cationic Emulsified Asphalt	9-02.1(6)
Anti-Stripping Additive	9-02.4
HMA Additive	9-02.5
Aggregates	9-03.8
Recycled Asphalt Pavement	9-03.8(3)B
Mineral Filler	9-03.8(5)
Recycled Material	9-03.21
Portland Cement	9-01
Sand	9-03.1(2)
(As noted in 5-04.3(5)C for crack sealing)	
Joint Sealant	9-04.2
Foam Backer Rod	9-04.2(3)A

The Contract documents may establish that the various mineral materials required for the manufacture of HMA will be furnished in whole or in part by the Contracting Agency. If the documents do not establish the furnishing of any of these mineral materials by the Contracting Agency, the Contractor shall be required to furnish such materials in the amounts required for the designated mix. Mineral materials include coarse and fine aggregates, and mineral filler.

The Contractor may choose to utilize recycled asphalt pavement (RAP) in the production of HMA. The RAP may be from pavements removed under the Contract, if any, or pavement material from an existing stockpile.

The Contractor may use up to 20 percent RAP by total weight of HMA with no additional sampling or testing of the RAP. The RAP shall be sampled and tested at a frequency of one sample for every 1,000 tons produced and not less than ten samples per project. The asphalt content and gradation test data shall be reported to the Contracting Agency when submitting the mix design for approval on the QPL. The Contractor shall include the RAP as part of the mix design as defined in these Specifications.

CITY OF FEDERAL WAY

**ON-CALL SIDEWALK AND CURB
REPLACEMENT
PROJECT #101-2023A**

SP-56

The grade of asphalt binder shall be as required by the Contract. Blending of asphalt binder from different sources is not permitted.

The Contractor may only use warm mix asphalt (WMA) processes in the production of HMA with 20 percent or less RAP by total weight of HMA. The Contractor shall submit to the Engineer for approval the process that is proposed and how it will be used in the manufacture of HMA.

Production of aggregates shall comply with the requirements of Section 3-01.

Preparation of stockpile site, the stockpiling of aggregates, and the removal of aggregates from stockpiles shall comply with the requirements of Section 3-02.

5-04.2(1) How to Get an HMA Mix Design on the QPL

If the contractor wishes to submit a mix design for inclusion in the Qualified Products List (QPL), please follow the WSDOT process outlined in Standard Specification 5-04.2(1).

5-04.2(1)A Vacant

5-04.2(2) Mix Design – Obtaining Project Approval

No paving shall begin prior to the approval of the mix design by the Engineer.

Nonstatistical evaluation will be used for all HMA not designated as Commercial HMA in the contract documents.

Commercial evaluation will be used for Commercial HMA and for other classes of HMA in the following applications: sidewalks, road approaches, ditches, slopes, paths, trails, gores, prelevel, and pavement repair. Other nonstructural applications of HMA accepted by commercial evaluation shall be as approved by the Project Engineer. Sampling and testing of HMA accepted by commercial evaluation will be at the option of the Project Engineer. The Proposal quantity of HMA that is accepted by commercial evaluation will be excluded from the quantities used in the determination of nonstatistical evaluation.

Nonstatistical Mix Design. Fifteen days prior to the first day of paving the contractor shall provide one of the following mix design verification certifications for Contracting Agency review;

- The WSDOT Mix Design Evaluation Report from the current WSDOT QPL, or one of the mix design verification certifications listed below.
- The proposed HMA mix design on WSDOT Form 350-042 with the seal and certification (stamp & signature) of a valid licensed Washington State Professional Engineer.
- The Mix Design Report for the proposed HMA mix design developed by a qualified City or County laboratory that is within one year of the approval date.**

The mix design shall be performed by a lab accredited by a national authority such as Laboratory Accreditation Bureau, L-A-B for Construction Materials Testing, The Construction Materials Engineering Council (CMEC's) ISO 17025 or AASHTO Accreditation Program (AAP) and shall supply evidence of participation in the AASHTO: resource proficiency sample program.

Mix designs for HMA accepted by Nonstatistical evaluation shall;

- Have the aggregate structure and asphalt binder content determined in accordance with WSDOT Standard Operating Procedure 732 and meet the requirements of Sections 9-03.8(2), except that Hamburg testing for ruts and stripping are at the discretion of the Engineer, and 9-03.8(6).
- Have anti-strip requirements, if any, for the proposed mix design determined in accordance with AASHTO T 283 or T 324, or based on historic anti-strip and aggregate source compatibility from previous WSDOT lab testing.

At the discretion of the Engineer, agencies may accept verified mix designs older than 12 months from the original verification date with a certification from the Contractor that the materials and sources are the same as those shown on the original mix design.

Commercial Evaluation Approval of a mix design for “Commercial Evaluation” will be based on a review of the Contractor’s submittal of WSDOT Form 350-042 (For commercial mixes, AASHTO T 324 evaluation is not required) or a Mix Design from the current WSDOT QPL or from one of the processes allowed by this section. Testing of the HMA by the Contracting Agency for mix design approval is not required.

For the Bid Item Commercial HMA, the Contractor shall select a class of HMA and design level of Equivalent Single Axle Loads (ESAL’s) appropriate for the required use.

5-04.2(2)B Using Warm Mix Asphalt Processes

The Contractor may elect to use additives that reduce the optimum mixing temperature or serve as a compaction aid for producing HMA. Additives include organic additives, chemical additives and foaming processes. The use of Additives is subject to the following:

- Do not use additives that reduce the mixing temperature more than allowed in Section 5-04.3(6) in the production of mixtures.
- Before using additives, obtain the Engineer’s approval using WSDOT Form 350-076 to describe the proposed additive and process.

5-04.3 Construction Requirements

5-04.3(1) Weather Limitations

Do not place HMA for wearing course on any Traveled Way beginning October 1st through March 31st of the following year without written concurrence from the Engineer.

Do not place HMA on any wet surface, or when the average surface temperatures are less than those specified below, or when weather conditions otherwise prevent the proper handling or finishing of the HMA.

Minimum Surface Temperature for Paving

Compacted Thickness (Feet)	Wearing Course	Other Courses
Less than 0.10	55°F	45°F
0.10 to .20	45°F	35°F
More than 0.20	35°F	35°F

5-04.3(2) Paving Under Traffic

When the Roadway being paved is open to traffic, the requirements of this Section shall apply.

The Contractor shall keep intersections open to traffic at all times except when paving the intersection or paving across the intersection. During such time, and provided that there has been an advance warning to the public, the intersection may be closed for the minimum time required to place and compact the mixture. In hot weather, the Engineer may require the application of water to the pavement to accelerate the finish rolling of the pavement and to shorten the time required before reopening to traffic.

Before closing an intersection, advance warning signs shall be placed and signs shall also be placed marking the detour or alternate route.

During paving operations, temporary pavement markings shall be maintained throughout the project. Temporary pavement markings shall be installed on the Roadway prior to opening to traffic. Temporary pavement markings shall be in accordance with Section 8-23.

All costs in connection with performing the Work in accordance with these requirements, except the cost of temporary pavement markings, shall be included in the unit Contract prices for the various Bid items involved in the Contract.

5-04.3(3) Equipment

5-04.3(3)A Mixing Plant

Plants used for the preparation of HMA shall conform to the following requirements:

1. **Equipment for Preparation of Asphalt Binder** – Tanks for the storage of asphalt binder shall be equipped to heat and hold the material at the required temperatures. The heating shall be accomplished by steam coils, electricity, or other approved means so that no flame shall be in contact with the storage tank. The circulating system for the asphalt binder shall be designed to ensure proper and continuous circulation during the operating period. A valve for the purpose of sampling the asphalt binder shall be placed in either the storage tank or in the supply line to the mixer.
2. **Thermometric Equipment** – An armored thermometer, capable of detecting temperature ranges expected in the HMA mix, shall be fixed in the asphalt binder feed line at a location near the charging valve at the mixer unit. The thermometer location shall be convenient and safe for access by Inspectors. The plant shall also

be equipped with an approved dial-scale thermometer, a mercury actuated thermometer, an electric pyrometer, or another approved thermometric instrument placed at the discharge chute of the drier to automatically register or indicate the temperature of the heated aggregates. This device shall be in full view of the plant operator.

3. **Heating of Asphalt Binder** – The temperature of the asphalt binder shall not exceed the maximum recommended by the asphalt binder manufacturer nor shall it be below the minimum temperature required to maintain the asphalt binder in a homogeneous state. The asphalt binder shall be heated in a manner that will avoid local variations in heating. The heating method shall provide a continuous supply of asphalt binder to the mixer at a uniform average temperature with no individual variations exceeding 25°F. Also, when a WMA additive is included in the asphalt binder, the temperature of the asphalt binder shall not exceed the maximum recommended by the manufacturer of the WMA additive.
4. **Sampling and Testing of Mineral Materials** – The HMA plant shall be equipped with a mechanical sampler for the sampling of the mineral materials. The mechanical sampler shall meet the requirements of Section 1-05.6 for the crushing and screening operation. The Contractor shall provide for the setup and operation of the field testing facilities of the Contracting Agency as provided for in Section 3-01.2(2).
5. **Sampling HMA** – The HMA plant shall provide for sampling HMA by one of the following methods:
 - a. A mechanical sampling device attached to the HMA plant.
 - b. Platforms or devices to enable sampling from the hauling vehicle without entering the hauling vehicle.

5-04.3(3)B Hauling Equipment

Trucks used for hauling HMA shall have tight, clean, smooth metal beds and shall have a cover of canvas or other suitable material of sufficient size to protect the mixture from adverse weather. Whenever the weather conditions during the work shift include, or are forecast to include, precipitation or an air temperature less than 45°F or when time from loading to unloading exceeds 30 minutes, the cover shall be securely attached to protect the HMA.

The contractor shall provide an environmentally benign means to prevent the HMA mixture from adhering to the hauling equipment. Excess release agent shall be drained prior to filling hauling equipment with HMA. Petroleum derivatives or other coating material that contaminate or alter the characteristics of the HMA shall not be used. For live bed trucks, the conveyor shall be in operation during the process of applying the release agent.

5-04.3(3)C Pavers

HMA pavers shall be self-contained, power-propelled units, provided with an internally heated vibratory screed and shall be capable of spreading and finishing courses of HMA plant mix material in lane widths required by the paving section shown in the Plans.

The HMA paver shall be in good condition and shall have the most current equipment available from the manufacturer for the prevention of segregation of the HMA mixture installed, in good condition, and in working order. The equipment certification shall list the make, model, and year of the paver and any equipment that has been retrofitted.

The screed shall be operated in accordance with the manufacturer's recommendations and shall effectively produce a finished surface of the required evenness and texture without tearing, shoving, segregating, or gouging the mixture. A copy of the manufacturer's recommendations shall be provided upon request by the Contracting Agency. Extensions will be allowed provided they produce the same results, including ride, density, and surface texture as obtained by the primary screed. Extensions without augers and an internally heated vibratory screed shall not be used in the Traveled Way.

When specified in the Contract, reference lines for vertical control will be required. Lines shall be placed on both outer edges of the Traveled Way of each Roadway. Horizontal control utilizing the reference line will be permitted. The grade and slope for intermediate lanes shall be controlled automatically from reference lines or by means of a mat referencing device and a slope control device. When the finish of the grade prepared for paving is superior to the established tolerances and when, in the opinion of the Engineer, further improvement to the line, grade, cross-section, and smoothness can best be achieved without the use of the reference line, a mat referencing device may be substituted for the reference line. Substitution of the device will be subject to the continued approval of the Engineer. A joint matcher may be used subject to the approval of the Engineer. The reference line may be removed after the completion of the first course of HMA when approved by the Engineer. Whenever the Engineer determines that any of these methods are failing to provide the necessary vertical control, the reference lines will be reinstalled by the Contractor.

The Contractor shall furnish and install all pins, brackets, tensioning devices, wire, and accessories necessary for satisfactory operation of the automatic control equipment.

If the paving machine in use is not providing the required finish, the Engineer may suspend Work as allowed by Section 1-08.6. Any cleaning or solvent type liquids spilled on the pavement shall be thoroughly removed before paving proceeds.

5-04.3(3)D Material Transfer Device or Material Transfer Vehicle

A Material Transfer Device/Vehicle (MTD/V) shall only be used with the Engineer's approval, unless other-wise required by the contract.

Where an MTD/V is required by the contract, the Engineer may approve paving without an MTD/V, at the request of the Contractor. The Engineer will determine if an equitable adjustment in cost or time is due.

When used, the MTD/V shall mix the HMA after delivery by the hauling equipment and prior to laydown by the paving machine. Mixing of the HMA shall be sufficient to obtain a uniform temperature throughout the mixture. If a windrow elevator is used, the length of the windrow may be limited in urban areas or through intersections, at the discretion of the Engineer.

To be approved for use, an MTV:

1. Shall be self-propelled vehicle, separate from the hauling vehicle or paver.
2. Shall not be connected to the hauling vehicle or paver.
3. May accept HMA directly from the haul vehicle or pick up HMA from a windrow.

4. Shall mix the HMA after delivery by the hauling equipment and prior to placement into the paving machine.
5. Shall mix the HMA sufficiently to obtain a uniform temperature throughout the mixture.

To be approved for use, an MTD:

1. Shall be positively connected to the paver.
2. May accept HMA directly from the haul vehicle or pick up HMA from a windrow.
3. Shall mix the HMA after delivery by the hauling equipment and prior to placement into the paving machine.
4. Shall mix the HMA sufficiently to obtain a uniform temperature throughout the mixture.

5-04.3(3)E Rollers

Rollers shall be of the steel wheel, vibratory, oscillatory, or pneumatic tire type, in good condition and capable of reversing without backlash. Operation of the roller shall be in accordance with the manufacturer's recommendations. When ordered by the Engineer for any roller planned for use on the project, the Contractor shall provide a copy of the manufacturer's recommendation for the use of that roller for compaction of HMA. The number and weight of rollers shall be sufficient to compact the mixture in compliance with the requirements of Section 5-04.3(10). The use of equipment that results in crushing of the aggregate will not be permitted. Rollers producing pickup, washboard, uneven compaction of the surface, displacement of the mixture or other undesirable results shall not be used.

5-04.3(4) Preparation of Existing Paved Surfaces

When the surface of the existing pavement or old base is irregular, the Contractor shall bring it to a uniform grade and cross-section as shown on the Plans or approved by the Engineer.

Preleveling of uneven or broken surfaces over which HMA is to be placed may be accomplished by using an asphalt paver, a motor patrol grader, or by hand raking, as approved by the Engineer.

Compaction of preleveling HMA shall be to the satisfaction of the Engineer and may require the use of small steel wheel rollers, plate compactors, or pneumatic rollers to avoid bridging across preleveled areas by the compaction equipment. Equipment used for the compaction of preleveling HMA shall be approved by the Engineer.

Before construction of HMA on an existing paved surface, the entire surface of the pavement shall be clean. All fatty asphalt patches, grease drippings, and other objectionable matter shall be entirely removed from the existing pavement. All pavements or bituminous surfaces shall be thoroughly cleaned of dust, soil, pavement grindings, and other foreign matter. All holes and small depressions shall be filled with an appropriate class of HMA. The surface of the patched area shall be leveled and compacted thoroughly. Prior to the application of tack coat, or paving, the condition of the surface shall be approved by the Engineer.

A tack coat of asphalt shall be applied to all paved surfaces on which any course of HMA is to be placed or abutted; except that tack coat may be omitted from clean, newly paved surfaces at the discretion of the Engineer. Tack coat shall be uniformly applied to cover the existing pavement with a thin film of residual asphalt free of streaks and bare spots at a rate between 0.02 and 0.10 gallons per square yard of retained asphalt. The rate of application shall be approved by the Engineer. A heavy application of tack coat shall be applied to all joints. For Roadways open to traffic, the application of tack coat shall be limited to surfaces that will be paved during the same working shift. The spreading equipment shall be equipped with a thermometer to indicate the temperature of the tack coat material.

Equipment shall not operate on tacked surfaces until the tack has broken and cured. If the Contractor's operation damages the tack coat it shall be repaired prior to placement of the HMA.

The tack coat shall be CSS-1, or CSS-1h emulsified asphalt. The CSS-1 and CSS-1h emulsified asphalt may be diluted once with water at a rate not to exceed one part water to one part emulsified asphalt. The tack coat shall have sufficient temperature such that it may be applied uniformly at the specified rate of application and shall not exceed the maximum temperature recommended by the emulsified asphalt manufacturer.

5-04.3(4)A Crack Sealing

5-04.3(4)A1 General

When the Proposal includes a pay item for crack sealing, seal all cracks ¼ inch in width and greater.

Cleaning: Ensure that cracks are thoroughly clean, dry and free of all loose and foreign material when filling with crack sealant material. Use a hot compressed air lance to dry and warm the pavement surfaces within the crack immediately prior to filling a crack with the sealant material. Do not overheat pavement. Do not use direct flame dryers. Routing cracks is not required.

Sand Slurry: For cracks that are to be filled with sand slurry, thoroughly mix the components and pour the mixture into the cracks until full. Add additional CSS-1 cationic emulsified asphalt to the sand slurry as needed for workability to ensure the mixture will completely fill the cracks. Strike off the sand slurry flush with the existing pavement surface and allow the mixture to cure. Top off cracks that were not completely filled with additional sand slurry. Do not place the HMA overlay until the slurry has fully cured.

The sand slurry shall consist of approximately 20 percent CSS-1 emulsified asphalt, approximately 2 percent portland cement, water (if required), and the remainder clean Class 1 or 2 fine aggregate per section 9-03.1(2). The components shall be thoroughly mixed and then poured into the cracks and joints until full. The following day, any cracks or joints that are not completely filled shall be topped off with additional sand slurry. After the sand slurry is placed, the filler shall be struck off flush with the existing pavement surface and allowed to cure. The HMA overlay shall not be placed until the slurry has fully cured. The requirements of Section 1-06 will not apply to the portland cement and sand used in the sand slurry.

In areas where HMA will be placed, use sand slurry to fill the cracks.

In areas where HMA will not be placed, fill the cracks as follows:

1. Cracks ¼ inch to 1 inch in width - fill with hot poured sealant.
2. Cracks greater than 1 inch in width – fill with sand slurry.

Hot Poured Sealant: For cracks that are to be filled with hot poured sealant, apply the material in accordance with these requirements and the manufacturer's recommendations. Furnish a Type 1 Working Drawing of the manufacturer's product information and recommendations to the Engineer prior to the start of work, including the manufacturer's recommended heating time and temperatures, allowable storage time and temperatures after initial heating, allowable reheating criteria, and application temperature range. Confine hot poured sealant material within the crack. Clean any overflow of sealant from the pavement surface. If, in the opinion of the Engineer, the Contractor's method of sealing the cracks with hot poured sealant results in an excessive amount of material on the pavement surface, stop and correct the operation to eliminate the excess material.

5-04.3(4)A2 Crack Sealing Areas Prior to Paving

In areas where HMA will be placed, use sand slurry to fill the cracks.

5-04.3(4)A3 Crack Sealing Areas Not to be Paved

In areas where HMA will not be placed, fill the cracks as follows:

- A. Cracks ¼ inch to 1 inch in width - fill with hot poured sealant.
- B. Cracks greater than 1 inch in width – fill with sand slurry.

5-04.3(4)B Vacant

5-04.3(4)C Pavement Repair

The Contractor shall excavate pavement repair areas and shall backfill these with HMA in accordance with the details shown in the Plans and as marked in the field. The Contractor shall conduct the excavation operations in a manner that will protect the pavement that is to remain. Pavement not designated to be removed that is damaged as a result of the Contractor's operations shall be repaired by the Contractor to the satisfaction of the Engineer at no cost to the Contracting Agency. The Contractor shall excavate only within one lane at a time unless approved otherwise by the Engineer. The Contractor shall not excavate more area than can be completely finished during the same shift, unless approved by the Engineer.

Unless otherwise shown in the Plans or determined by the Engineer, excavate to a depth of 1.0 feet. The Engineer will make the final determination of the excavation depth required. The minimum width of any pavement repair area shall be 40 inches unless shown otherwise in the Plans. Before any excavation, the existing pavement shall be sawcut or shall be removed by a pavement grinder. Excavated materials will become the property of the Contractor and shall be disposed of in a Contractor-provided site off the Right of Way or used in accordance with Sections 2-02.3(3) or 9-03.21.

Asphalt for tack coat shall be required as specified in Section 5-04.3(4). A heavy application of tack coat shall be applied to all surfaces of existing pavement in the pavement repair area.

Placement of the HMA backfill shall be accomplished in lifts not to exceed 0.35-foot compacted depth. Lifts that exceed 0.35-foot of compacted depth may be accomplished with the approval of the Engineer. Each lift shall be thoroughly compacted by a mechanical tamper or a roller.

5-04.3(5) Producing/Stockpiling Aggregates and RAP

Aggregates and RAP shall be stockpiled according to the requirements of Section 3-02. Sufficient storage space shall be provided for each size of aggregate and RAP. Materials shall be removed from stockpile(s) in a manner to ensure minimal segregation when being moved to the HMA plant for processing into the final mixture. Different aggregate sizes shall be kept separated until they have been delivered to the HMA plant.

5-04.3(5)A Vacant

5-04.3(6) Mixing

After the required amount of mineral materials, asphalt binder, recycling agent and anti-stripping additives have been introduced into the mixer the HMA shall be mixed until complete and uniform coating of the particles and thorough distribution of the asphalt binder throughout the mineral materials is ensured.

When discharged, the temperature of the HMA shall not exceed the optimum mixing temperature by more than 25°F as shown on the reference mix design report or as approved by the Engineer. Also, when a WMA additive is included in the manufacture of HMA, the discharge temperature of the HMA shall not exceed the maximum recommended by the manufacturer of the WMA additive. A maximum water content of 2 percent in the mix, at discharge, will be allowed providing the water causes no problems with handling, stripping, or flushing. If the water in the HMA causes any of these problems, the moisture content shall be reduced as directed by the Engineer.

Storing or holding of the HMA in approved storage facilities will be permitted with approval of the Engineer, but in no event shall the HMA be held for more than 24 hours. HMA held for more than 24 hours after mixing shall be rejected. Rejected HMA shall be disposed of by the Contractor at no expense to the Contracting Agency. The storage facility shall have an accessible device located at the top of the cone or about the third point. The device shall indicate the amount of material in storage. No HMA shall be accepted from the storage facility when the HMA in storage is below the top of the cone of the storage facility, except as the storage facility is being emptied at the end of the working shift.

Recycled asphalt pavement (RAP) utilized in the production of HMA shall be sized prior to entering the mixer so that a uniform and thoroughly mixed HMA is produced. If there is evidence of the recycled asphalt pavement not breaking down during the heating and mixing of the HMA, the Contractor shall immediately suspend the use of the RAP until changes have been approved by the Engineer. After the required amount of mineral materials, RAP, new asphalt binder and asphalt rejuvenator have been introduced into the mixer the HMA shall be mixed until complete and uniform coating of the particles and

thorough distribution of the asphalt binder throughout the mineral materials, and RAP is ensured.

5-04.3(7) Spreading and Finishing

The mixture shall be laid upon an approved surface, spread, and struck off to the grade and elevation established. HMA pavers complying with Section 5-04.3(3) shall be used to distribute the mixture. Unless otherwise directed by the Engineer, the nominal compacted depth of any layer of any course shall not exceed the following:

HMA Class 1"	0.35 feet
HMA Class ¾" and HMA Class ½"	
wearing course	0.30 feet
other courses	0.35 feet
HMA Class ⅜"	0.15 feet

On areas where irregularities or unavoidable obstacles make the use of mechanical spreading and finishing equipment impractical, the paving may be done with other equipment or by hand.

When more than one JMF is being utilized to produce HMA, the material produced for each JMF shall be placed by separate spreading and compacting equipment. The intermingling of HMA produced from more than one JMF is prohibited. Each strip of HMA placed during a work shift shall conform to a single JMF established for the class of HMA specified unless there is a need to make an adjustment in the JMF.

5-04.3(8) Aggregate Acceptance Prior to Incorporation in HMA

For HMA accepted by nonstatistical evaluation the aggregate properties of sand equivalent, uncompacted void content and fracture will be evaluated in accordance with Section 3-04. Sampling and testing of aggregates for HMA accepted by commercial evaluation will be at the option of the Engineer.

5-04.3(9) HMA Mixture Acceptance

Acceptance of HMA shall be as provided under nonstatistical, or commercial evaluation.

Nonstatistical evaluation will be used for the acceptance of HMA unless Commercial Evaluation is specified.

Commercial evaluation will be used for Commercial HMA and for other classes of HMA in the following applications: sidewalks, road approaches, ditches, slopes, paths, trails, gores, prelevel, temporary pavement, and pavement repair. Other nonstructural applications of HMA accepted by commercial evaluation shall be as approved by the Engineer. Sampling and testing of HMA accepted by commercial evaluation will be at the option of the Engineer.

The mix design will be the initial JMF for the class of HMA. The Contractor may request a change in the JMF. Any adjustments to the JMF will require the approval of the Engineer and may be made in accordance with this section.

HMA Tolerances and Adjustments

- Job Mix Formula Tolerances** – The constituents of the mixture at the time of acceptance shall be within tolerance. The tolerance limits will be established as follows:

For Asphalt Binder and Air Voids (Va), the acceptance limits are determined by adding the tolerances below to the approved JMF values. These values will also be the Upper Specification Limit (USL) and Lower Specification Limit (LSL) required in Section 1-06.2(2)D2

Property	Non-Statistical Evaluation	Commercial Evaluation
Asphalt Binder	+/- 0.5%	+/- 0.7%
Air Voids, Va	2.5% min. and 5.5% max	N/A

For Aggregates in the mixture:

- First, determine preliminary upper and lower acceptance limits by applying the following tolerances to the approved JMF.

Aggregate Percent Passing	Non-Statistical Evaluation	Commercial Evaluation
1", ¾", ½", and 3/8" sieves	+/- 6%	+/- 8%
No. 4 sieve	+/-6%	+/- 8%
No. 8 Sieve	+/- 6%	+/-8%
No. 200 sieve	+/- 2.0%	+/- 3.0%

- Second, adjust the preliminary upper and lower acceptance limits determined from step (a) the minimum amount necessary so that none of the aggregate properties are outside the control points in Section 9-03.8(6). The resulting values will be the upper and lower acceptance limits for aggregates, as well as the USL and LSL required in Section 1-06.2(2)D2.
- Job Mix Formula Adjustments** – An adjustment to the aggregate gradation or asphalt binder content of the JMF requires approval of the Engineer. Adjustments to the JMF will only be considered if the change produces material of equal or better quality and may require the development of a new mix design if the adjustment exceeds the amounts listed below.
 - Aggregates** –2 percent for the aggregate passing the 1½", 1", ¾", ½", ⅜", and the No. 4 sieves, 1 percent for aggregate passing the No. 8 sieve, and 0.5 percent for the aggregate passing the No. 200 sieve. The adjusted JMF shall be within the range of the control points in Section 9-03.8(6).
 - Asphalt Binder Content** – The Engineer may order or approve changes to asphalt binder content. The maximum adjustment from the approved mix design for the asphalt binder content shall be 0.3 percent

5-04.3(9)A Vacant

5-04.3(9)B Vacant

5-04.3(9)C Mixture Acceptance – Nonstatistical Evaluation

HMA mixture which is accepted by Nonstatistical Evaluation will be evaluated by the Contracting Agency by dividing the HMA tonnage into lots.

5-04.3(9)C1 Mixture Nonstatistical Evaluation – Lots and Sublots

A lot is represented by randomly selected samples of the same mix design that will be tested for acceptance. A lot is defined as the total quantity of material or work produced for each Job Mix Formula placed. Only one lot per JMF is expected. A subplot shall be equal to one day's production or 800 tons, whichever is less except that the final subplot will be a minimum of 400 tons and may be increased to 1200 tons.

All of the test results obtained from the acceptance samples from a given lot shall be evaluated collectively. If the Contractor requests a change to the JMF that is approved, the material produced after the change will be evaluated on the basis of the new JMF for the remaining sublots in the current lot and for acceptance of subsequent lots. For a lot in progress with a CPF less than 0.75, a new lot will begin at the Contractor's request after the Engineer is satisfied that material conforming to the Specifications can be produced.

Sampling and testing for evaluation shall be performed on the frequency of one sample per subplot.

5-04.3(9)C2 Mixture Nonstatistical Evaluation Sampling

Samples for acceptance testing shall be obtained by the Contractor when ordered by the Engineer. The Contractor shall sample the HMA mixture in the presence of the Engineer and in accordance with AASH-TO T 168. A minimum of three samples should be taken for each class of HMA placed on a project. If used in a structural application, at least one of the three samples shall to be tested.

Sampling and testing HMA in a Structural application where quantities are less than 400 tons is at the dis-cretion of the Engineer.

For HMA used in a structural application and with a total project quantity less than 800 tons but more than 400 tons, a minimum of one acceptance test shall be performed. In all cases, a minimum of 3 samples will be obtained at the point of acceptance, a minimum of one of the three samples will be tested for conformance to the JMF:

- If the test results are found to be within specification requirements, additional testing will be at the Engineer's discretion.
- If test results are found not to be within specification requirements, additional testing of the remaining samples to determine a Composite Pay Factor (CPF) shall be performed.

5-04.3(9)C3 Mixture Nonstatistical Evaluation – Acceptance Testing

Testing of HMA for compliance of Va will at the option of the Contracting Agency. If tested, compliance of Va will use WSDOT SOP 731.

Testing for compliance of asphalt binder content will be by WSDOT FOP for AASHTO T 308.

Testing for compliance of gradation will be by FOP for WAQTC T 27/T 11.

5-04.3(9)C4 Mixture Nonstatistical Evaluation – Pay Factors

For each lot of material falling outside the tolerance limits in 5-04.3(9), the Contracting Agency will determine a Composite Pay Factor (CPF) using the following price adjustment factors:

Table of Price Adjustment Factors	
Constituent	Factor “f”

All aggregate passing: 1½", 1", ¾", ½", ⅜" and No.4 sieves	2
All aggregate passing No. 8 sieve	15
All aggregate passing No. 200 sieve	20
Asphalt binder	40
Air Voids (Va) (where applicable)	20

Each lot of HMA produced under Nonstatistical Evaluation and having all constituents falling within the tolerance limits of the job mix formula shall be accepted at the unit Contract price with no further evaluation. When one or more constituents fall outside the nonstatistical tolerance limits in the Job Mix Formula shown in Table of Price Adjustment Factors, the lot shall be evaluated in accordance with Section 1-06.2 to determine the appropriate CPF. The nonstatistical tolerance limits will be used in the calculation of the CPF and the maximum CPF shall be 1.00. When less than three sublots exist, backup samples of the existing sublots or samples from the Roadway shall be tested to provide a minimum of three sets of results for evaluation.

5-04.3(9)C5 Vacant

5-04.3(9)C6 Mixture Nonstatistical Evaluation – Price Adjustments

For each lot of HMA mix produced under Nonstatistical Evaluation when the calculated CPF is less than 1.00, a Nonconforming Mix Factor (NCMF) will be determined. The NCMF equals the algebraic difference of CPF minus 1.00 multiplied by 60 percent. The total job mix compliance price adjustment will be calculated as the product of the NCMF, the quantity of HMA in the lot in tons, and the unit Contract price per ton of mix.

If a constituent is not measured in accordance with these Specifications, its individual pay factor will be considered 1.00 in calculating the Composite Pay Factor (CPF).

5-04.3(9)C7 Mixture Nonstatistical Evaluation - Retests

The Contractor may request a subplot be retested. To request a retest, the Contractor shall submit a written request within 7 calendar days after the specific test results have been received. A split of the original acceptance sample will be retested. The split of the sample will not be tested with the same tester that ran the original acceptance test. The sample will be tested for a complete gradation analysis, asphalt binder content, and, at the option of the agency, Va. The results of the retest will be used for the acceptance of the HMA in place of the original subplot sample test results. The cost of testing will be deducted from any monies due or that may come due the Contractor under the Contract at the rate of \$500 per sample.

5-04.3 (9)D Mixture Acceptance – Commercial Evaluation

If sampled and tested, HMA produced under Commercial Evaluation and having all constituents falling within the tolerance limits of the job mix formula shall be accepted at the unit Contract price with no further evaluation. When one or more constituents fall outside the commercial tolerance limits in the Job Mix Formula shown in 5-04.3(9), the lot shall be evaluated in accordance with Section 1-06.2 to determine the appropriate CPF. The commercial tolerance limits will be used in the calculation of the CPF and the maximum CPF shall be 1.00. When less than three sublots exist, backup samples of the

existing sublots or samples from the street shall be tested to provide a minimum of three sets of results for evaluation.

For each lot of HMA mix produced and tested under Commercial Evaluation when the calculated CPF is less than 1.00, a Nonconforming Mix Factor (NCMF) will be determined. The NCMF equals the algebraic difference of CPF minus 1.00 multiplied by 60 percent. The Job Mix Compliance Price Adjustment will be calculated as the product of the NCMF, the quantity of HMA in the lot in tons, and the unit Contract price per ton of mix.

If a constituent is not measured in accordance with these Specifications, its individual pay factor will be considered 1.00 in calculating the Composite Pay Factor (CPF).

5-04.3(10) HMA Compaction Acceptance

HMA mixture accepted by nonstatistical evaluation that is used in traffic lanes, including lanes for intersections, ramps, truck climbing, weaving, and speed change, and having a specified compacted course thickness greater than 0.10-foot, shall be compacted to a specified level of relative density. The specified level of relative density shall be a Composite Pay Factor (CPF) of not less than 0.75 when evaluated in accordance with Section 1-06.2, using a LSL of 92.0 (minimum of 92 percent of the maximum density). The maximum density shall be determined by WSDOT FOP for AASHTO T 729. The specified level of density attained will be determined by the evaluation of the density of the pavement. The density of the pavement shall be determined in accordance with WSDOT FOP for WAQTC TM 8, except that gauge correlation will be at the discretion of the Engineer, when using the nuclear density gauge and WSDOT SOP 736 when using cores to determine density.

Tests for the determination of the pavement density will be taken in accordance with the required procedures for measurement by a nuclear density gauge or roadway cores after completion of the finish rolling.

If the Contracting Agency uses a nuclear density gauge to determine density the test procedures FOP for WAQTC TM 8 and WSDOT SOP T 729 will be used on the day the mix is placed and prior to opening to traffic.

Roadway cores for density may be obtained by either the Contracting Agency or the Contractor in accordance with WSDOT SOP 734. The core diameter shall be 4-inches minimum, unless otherwise approved by the Engineer. Roadway cores will be tested by the Contracting Agency in accordance with WSDOT FOP for AASHTO T 166.

If the Contract includes the Bid item "Roadway Core" the cores shall be obtained by the Contractor in the presence of the Engineer on the same day the mix is placed and at locations designated by the Engineer. If the Contract does not include the Bid item "Roadway Core" the Contracting Agency will obtain the cores.

For a lot in progress with a CPF less than 0.75, a new lot will begin at the Contractor's request after the Engineer is satisfied that material conforming to the Specifications can be produced.

HMA mixture accepted by commercial evaluation and HMA constructed under conditions other than those listed above shall be compacted on the basis of a test point evaluation of

the compaction train. The test point evaluation shall be performed in accordance with instructions from the Engineer. The number of passes with an approved compaction train, required to attain the maximum test point density, shall be used on all subsequent paving.

HMA for preleveling shall be thoroughly compacted. HMA that is used for preleveling wheel rutting shall be compacted with a pneumatic tire roller unless otherwise approved by the Engineer.

Test Results

For a subplot that has been tested with a nuclear density gauge that did not meet the minimum of 92 percent of the reference maximum density in a compaction lot with a CPF below 1.00 and thus subject to a price reduction or rejection, the Contractor may request that a core be used for determination of the relative density of the subplot. The relative density of the core will replace the relative density determined by the nuclear density gauge for the subplot and will be used for calculation of the CPF and acceptance of HMA compaction lot.

When cores are taken by the Contracting Agency at the request of the Contractor, they shall be requested by noon of the next workday after the test results for the subplot have been provided or made available to the Contractor. Core locations shall be outside of wheel paths and as determined by the Engineer. Traffic control shall be provided by the Contractor as requested by the Engineer. Failure by the Contractor to provide the requested traffic control will result in forfeiture of the request for cores. When the CPF for the lot based on the results of the HMA cores is less than 1.00, the cost for the coring will be deducted from any monies due or that may become due the Contractor under the Contract at the rate of \$200 per core and the Contractor shall pay for the cost of the traffic control.

5-04.3(10)A HMA Compaction – General Compaction Requirements

Compaction shall take place when the mixture is in the proper condition so that no undue displacement, cracking, or shoving occurs. Areas inaccessible to large compaction equipment shall be compacted by other mechanical means. Any HMA that becomes loose, broken, contaminated, shows an excess or deficiency of asphalt, or is in any way defective, shall be removed and replaced with new hot mix that shall be immediately compacted to conform to the surrounding area.

The type of rollers to be used and their relative position in the compaction sequence shall generally be the Contractor's option, provided the specified densities are attained. Unless the Engineer has approved otherwise, rollers shall only be operated in the static mode when the internal temperature of the mix is less than 175°F. Regardless of mix temperature, a roller shall not be operated in a mode that results in checking or cracking of the mat. Rollers shall only be operated in static mode on bridge decks.

5-04.3(10)B HMA Compaction – Cyclic Density

Low cyclic density areas are defined as spots or streaks in the pavement that are less than 90 percent of the theoretical maximum density. At the Engineer's discretion, the Engineer may evaluate the HMA pavement for low cyclic density, and when doing so will follow WSDOT SOP 733. A \$500 Cyclic Density Price Adjustment will be assessed for any 500-foot section with two or more density readings below 90 percent of the theoretical maximum density.

5-04.3(10)C Vacant

5-04.3(10)D HMA Nonstatistical Compaction

5-04.3(10)D1 HMA Nonstatistical Compaction – Lots and Sublots

HMA compaction which is accepted by nonstatistical evaluation will be based on acceptance testing performed by the Contracting Agency dividing the project into compaction lots.

A lot is represented by randomly selected samples of the same mix design that will be tested for acceptance. A lot is defined as the total quantity of material or work produced for each Job Mix Formula placed. Only one lot per JMF is expected. A subplot shall be equal to one day's production or 400 tons, whichever is less except that the final subplot will be a minimum of 200 tons and may be increased to 800 tons. Testing for compaction will be at the rate of 5 tests per subplot per WSDOT T 738.

The subplot locations within each density lot will be determined by the Engineer. For a lot in progress with a CPF less than 0.75, a new lot will begin at the Contractor's request after the Engineer is satisfied that material conforming to the Specifications can be produced.

HMA mixture accepted by commercial evaluation and HMA constructed under conditions other than those listed above shall be compacted on the basis of a test point evaluation of the compaction train. The test point evaluation shall be performed in accordance with instructions from the Engineer. The number of passes with an approved compaction train, required to attain the maximum test point density, shall be used on all subsequent paving.

HMA for preleveling shall be thoroughly compacted. HMA that is used to prelevel wheel ruts shall be compacted with a pneumatic tire roller unless otherwise approved by the Engineer.

5-04.3(10)D2 HMA Compaction Nonstatistical Evaluation – Acceptance Testing

The location of the HMA compaction acceptance tests will be randomly selected by the Engineer from within each subplot, with one test per subplot.

5-04.3(10)D3 HMA Nonstatistical Compaction – Price Adjustments

For each compaction lot with one or two sublots, having all sublots attain a relative density that is 92 percent of the reference maximum density the HMA shall be accepted at the unit Contract price with no further evaluation. When a subplot does not attain a relative density that is 92 percent of the reference maximum density, the lot shall be evaluated in accordance with Section 1-06.2 to determine the appropriate CPF. The maximum CPF shall be 1.00, however, lots with a calculated CPF in excess of 1.00 will be used to offset lots with CPF values below 1.00 but greater than 0.90. Lots with CPF lower than 0.90 will be evaluated for compliance per 5-04.3(11). Additional testing by either a nuclear moisture-density gauge or cores will be completed as required to provide a minimum of three tests for evaluation.

For compaction below the required 92% a Non-Conforming Compaction Factor (NCCF) will be determined. The NCCF equals the algebraic difference of CPF minus 1.00 multiplied by 40 percent. The Compaction Price Adjustment will be calculated as the

product of CPF, the quantity of HMA in the compaction control lot in tons, and the unit Contract price per ton of mix.

5-04.3(11) Reject Work

5-04.3(11)A Reject Work General

Work that is defective or does not conform to Contract requirements shall be rejected. The Contractor may propose, in writing, alternatives to removal and replacement of rejected material. Acceptability of such alternative proposals will be determined at the sole discretion of the Engineer. HMA that has been rejected is subject to the requirements in Section 1-06.2(2) and this specification, and the Contractor shall submit a corrective action proposal to the Engineer for approval.

5-04.3(11)B Rejection by Contractor

The Contractor may, prior to sampling, elect to remove any defective material and replace it with new material. Any such new material will be sampled, tested, and evaluated for acceptance.

5-04.3(11)C Rejection Without Testing (Mixture or Compaction)

The Engineer may, without sampling, reject any batch, load, or section of Roadway that appears defective. Material rejected before placement shall not be incorporated into the pavement. Any rejected section of Roadway shall be removed.

No payment will be made for the rejected materials or the removal of the materials unless the Contractor requests that the rejected material be tested. If the Contractor elects to have the rejected material tested, a minimum of three representative samples will be obtained and tested. Acceptance of rejected material will be based on conformance with the nonstatistical acceptance Specification. If the CPF for the rejected material is less than 0.75, no payment will be made for the rejected material; in addition, the cost of sampling and testing shall be borne by the Contractor. If the CPF is greater than or equal to 0.75, the cost of sampling and testing will be borne by the Contracting Agency. If the material is rejected before placement and the CPF is greater than or equal to 0.75, compensation for the rejected material will be at a CPF of 0.75. If rejection occurs after placement and the CPF is greater than or equal to 0.75, compensation for the rejected material will be at the calculated CPF with an addition of 25 percent of the unit Contract price added for the cost of removal and disposal.

5-04.3(11)D Rejection - A Partial Sublot

In addition to the random acceptance sampling and testing, the Engineer may also isolate from a normal sublot any material that is suspected of being defective in relative density, gradation or asphalt binder content. Such isolated material will not include an original sample location. A minimum of three random samples of the suspect material will be obtained and tested. The material will then be statistically evaluated as an independent lot in accordance with Section 1-06.2(2).

5-04.3(11)E Rejection - An Entire Sublot

An entire sublot that is suspected of being defective may be rejected. When a sublot is rejected a minimum of two additional random samples from this sublot will be obtained. These additional samples and the original sublot will be evaluated as an independent lot in accordance with Section 1-06.2(2).

5-04.3(11)F Rejection - A Lot in Progress

The Contractor shall shut down operations and shall not resume HMA placement until such time as the Engineer is satisfied that material conforming to the Specifications can be produced:

1. When the Composite Pay Factor (CPF) of a lot in progress drops below 1.00 and the Contractor is taking no corrective action, or
2. When the Pay Factor (PF) for any constituent of a lot in progress drops below 0.95 and the Contractor is taking no corrective action, or
3. When either the PFi for any constituent or the CPF of a lot in progress is less than 0.75.

5-04.3(11)G Rejection - An Entire Lot (Mixture or Compaction)

An entire lot with a CPF of less than 0.75 will be rejected.

5-04.3(12) Joints

5-04.3(12)A HMA Joints

5-04.3(12)A1 Transverse Joints

The Contractor shall conduct operations such that the placing of the top or wearing course is a continuous operation or as close to continuous as possible. Unscheduled transverse joints will be allowed and the roller may pass over the unprotected end of the freshly laid mixture only when the placement of the course must be discontinued for such a length of time that the mixture will cool below compaction temperature. When the Work is resumed, the previously compacted mixture shall be cut back to produce a slightly beveled edge for the full thickness of the course.

A temporary wedge of HMA constructed on a 20H:1V shall be constructed where a transverse joint as a result of paving or planing is open to traffic. The HMA in the temporary wedge shall be separated from the permanent HMA by strips of heavy wrapping paper or other methods approved by the Engineer. The wrapping paper shall be removed and the joint trimmed to a slightly beveled edge for the full thickness of the course prior to resumption of paving.

The material that is cut away shall be wasted and new mix shall be laid against the cut. Rollers or tamping irons shall be used to seal the joint.

5-04.3(12)A2 Longitudinal Joints

The longitudinal joint in any one course shall be offset from the course immediately below by not more than 6 inches nor less than 2 inches. All longitudinal joints constructed in the wearing course shall be located at a lane line or an edge line of the Traveled Way. A notched wedge joint shall be constructed along all longitudinal joints in the wearing surface of new HMA unless otherwise approved by the Engineer. The notched wedge joint shall have a vertical edge of not less than the maximum aggregate size or more than ½ of the compacted lift thickness and then taper down on a slope not steeper than 4H:1V. The sloped portion of the HMA notched wedge joint shall be uniformly compacted.

5-04.3(12)B Bridge Paving Joint Seals

5-04.3(12)B1 HMA Sawcut and Seal

Prior to placing HMA on the bridge deck, establish sawcut alignment points at both ends of the bridge paving joint seals to be placed at the bridge ends, and at interior joints within the bridge deck when and where shown in the Plans. Establish the sawcut alignment points in a manner that they remain functional for use in aligning the sawcut after placing the overlay.

Submit a Type 1 Working Drawing consisting of the sealant manufacturer's application procedure.

Construct the bridge paving joint seal as specified in the Plans and in accordance with the detail shown in the Standard Plans. Construct the sawcut in accordance with the detail shown in the Standard Plan. Construct the sawcut in accordance with Section 5-05.3(8)B and the manufacturer's application procedure.

5-04.3(12)B2 Paved Panel Joint Seal

Construct the paved panel joint seal in accordance with the requirements specified in section 5-04.3(12)B1 and the following requirement:

1. Clean and seal the existing joint between concrete panels in accordance with Section 5-01.3(8) and the details shown in the Standard Plans.

5-04.3(13) Surface Smoothness

The completed surface of all courses shall be of uniform texture, smooth, uniform as to crown and grade, and free from defects of all kinds. The completed surface of the wearing course shall not vary more than $\frac{1}{8}$ inch from the lower edge of a 10-foot straightedge placed on the surface parallel to the centerline. The transverse slope of the completed surface of the wearing course shall vary not more than $\frac{1}{4}$ inch in 10 feet from the rate of transverse slope shown in the Plans.

When deviations in excess of the above tolerances are found that result from a high place in the HMA, the pavement surface shall be corrected by one of the following methods:

1. Removal of material from high places by grinding with an approved grinding machine, or
2. Removal and replacement of the wearing course of HMA, or
3. By other method approved by the Engineer.

Correction of defects shall be carried out until there are no deviations anywhere greater than the allowable tolerances.

Deviations in excess of the above tolerances that result from a low place in the HMA and deviations resulting from a high place where corrective action, in the opinion of the Engineer, will not produce satisfactory results will be accepted with a price adjustment. The Engineer shall deduct from monies due or that may become due to the Contractor the sum of \$500.00 for each and every section of single traffic lane 100 feet in length in which any excessive deviations described above are found.

When utility appurtenances such as manhole covers and valve boxes are located in the traveled way, the utility appurtenances shall be adjusted to the finished grade prior to paving. This requirement may be waived when requested by the Contractor, at the discretion of the Engineer or when the adjustment details provided in the project plan or specifications call for utility appurtenance adjustments after the completion of paving.

Utility appurtenance adjustment discussions will be included in the Pre-Paving planning (5-04.3(14)B3). Submit a written request to waive this requirement to the Engineer prior to the start of paving.

5-04.3(14)B Paving and Planing Under Traffic

5-04.3(14)B1 General

In addition the requirements of Section 1-07.23 and the traffic controls required in Section 1-10, and unless the Contract specifies otherwise or the Engineer approves, the Contractor must comply with the following:

1. Intersections:
 - a. Keep intersections open to traffic at all times, except when paving or planing operations through an intersection requires closure. Such closure must be kept to the minimum time required to place and compact the HMA mixture, or plane as appropriate. For paving, schedule such closure to individual lanes or portions thereof that allows the traffic volumes and schedule of traffic volumes required in the approved traffic control plan. Schedule work so that adjacent intersections are not impacted at the same time and comply with the traffic control restrictions required by the Traffic Engineer. Each individual intersection closure or partial closure, must be addressed in the traffic control plan, which must be submitted to and accepted by the Engineer, see Section 1-10.2(2).
 - b. When planing or paving and related construction must occur in an intersection, consider scheduling and sequencing such work into quarters of the intersection, or half or more of an intersection with side street detours. Be prepared to sequence the work to individual lanes or portions thereof.
 - c. Should closure of the intersection in its entirety be necessary, and no trolley service is impacted, keep such closure to the minimum time required to place and compact the HMA mixture, plane, remove asphalt, tack coat, and as needed.
 - d. Any work in an intersection requires advance warning in both signage and a number of Working Days advance notice as determined by the Engineer, to alert traffic and emergency services of the intersection closure or partial closure.
 - e. Allow new compacted HMA asphalt to cool to ambient temperature before any traffic is allowed on it. Traffic is not allowed on newly placed asphalt until approval has been obtained from the Engineer.
2. Temporary centerline marking, post-paving temporary marking, temporary stop bars, and maintaining temporary pavement marking must comply with Section 8-23.
3. Permanent pavement marking must comply with Section 8-22.

5-04.3(14)B2 Submittals – Planing Plan and HMA Paving Plan

The Contractor must submit a separate planing plan and a separate paving plan to the Engineer at least 5 Working Days in advance of each operation's activity start date. These plans must show how the moving operation and traffic control are coordinated, as they will be discussed at the pre-planing briefing and pre-paving briefing. When requested by the Engineer, the Contractor must provide each operation's traffic control plan on 24 x 36 inch or larger size Shop Drawings with a scale showing both the area of operation and sufficient detail of traffic beyond the area of operation where detour traffic may be required. The scale on the Shop Drawings is 1 inch = 20 feet, which may be changed if the Engineer agrees sufficient detail is shown.

The planing operation and the paving operation include, but are not limited to, metal detection, removal of asphalt and temporary asphalt of any kind, tack coat and drying, staging of supply trucks, paving trains, rolling, scheduling, and as may be discussed at the briefing.

When intersections will be partially or totally blocked, provide adequately sized and noticeable signage alerting traffic of closures to come, a minimum 2 Working Days in advance. The traffic control plan must show where peace officers will be stationed when signalization is or may be, countermanded, and show areas where flaggers are proposed.

At a minimum, the planing and the paving plan must include:

1. A copy of the accepted traffic control plan, see Section 1-10.2(2), detailing each day's traffic control as it relates to the specific requirements of that day's planing and paving. Briefly describe the sequencing of traffic control consistent with the proposed planing and paving sequence, and scheduling of placement of temporary pavement markings and channelizing devices after each day's planing, and paving.
2. A copy of each intersection's traffic control plan.
3. Haul routes from Supplier facilities, and locations of temporary parking and staging areas, including return routes. Describe the complete round trip as it relates to the sequencing of paving operations.
4. Names and locations of HMA Supplier facilities to be used.
5. List of all equipment to be used for paving.
6. List of personnel and associated job classification assigned to each piece of paving equipment.
7. Description (geometric or narrative) of the scheduled sequence of planing and of paving, and intended area of planing and of paving for each day's work, must include the directions of proposed planing and of proposed paving, sequence of adjacent lane paving, sequence of skipped lane paving, intersection planing and paving scheduling and sequencing, and proposed notifications and coordinations to be timely made. The plan must show HMA joints relative to the final pavement marking lane lines.
8. Names, job titles, and contact information for field, office, and plant supervisory personnel.
9. A copy of the approved Mix Designs.
10. Tonnage of HMA to be placed each day.
11. Approximate times and days for starting and ending daily operations.

5-04.3(14)B3 Pre-Paving and Pre-Planing Briefing

At least 2 Working Days before the first paving operation and the first planing operation, or as scheduled by the Engineer for future paving and planing operations to ensure the Contractor has adequately prepared for notifying and coordinating as required in the Contract, the Contractor must be prepared to discuss that day's operations as they relate to other entities and to public safety and convenience, including driveway and business access, garbage truck operations, Metro transit operations and working around energized overhead wires, school and nursing home and hospital and other accesses, other contractors who may be operating in the area, pedestrian and bicycle traffic, and emergency services. The Contractor, and Subcontractors that may be part of that day's operations, must meet with the Engineer and discuss the proposed operation as it relates to the submitted planing plan and paving plan, approved traffic control plan, and public convenience and safety. Such discussion includes, but is not limited to:

1. General for both Paving Plan and for Planing Plan:
 - a. The actual times of starting and ending daily operations.
 - b. In intersections, how to break up the intersection, and address traffic control and signalization for that operation, including use of peace officers.
 - c. The sequencing and scheduling of paving operations and of planing operations, as applicable, as it relates to traffic control, to public convenience and safety, and to other contractors who may operate in the Project Site.
 - d. Notifications required of Contractor activities, and coordinating with other entities and the public as necessary.
 - e. Description of the sequencing of installation and types of temporary pavement markings as it relates to planning and to paving.
 - f. Description of the sequencing of installation of, and the removal of, temporary pavement patch material around exposed castings and as may be needed
 - g. Description of procedures and equipment to identify hidden metal in the pavement, such as survey monumentation, monitoring wells, street car rail, and castings, before planning, see Section 5-04.3(14)B2.
 - h. Description of how flaggers will be coordinated with the planing, paving, and related operations.
 - i. Description of sequencing of traffic controls for the process of rigid pavement base repairs.
 - j. Other items the Engineer deems necessary to address.
2. Paving – additional topics:
 - a. When to start applying tack and coordinating with paving.
 - b. Types of equipment and numbers of each type equipment to be used. If more pieces of equipment than personnel are proposed, describe the sequencing of the personnel operating the types of equipment. Discuss the continuance of operator personnel for each type equipment as it relates to meeting Specification requirements.
 - c. Number of JMFs to be placed, and if more than one JMF how the Contractor will ensure different JMFs are distinguished, how pavers and MTVs are distinguished if more than one JMF is being placed at the time, and how pavers and MTVs are cleaned so that one JMF does not adversely influence the other JMF.
 - d. Description of contingency plans for that day's operations such as equipment breakdown, rain out, and Supplier shutdown of operations.

- e. Number of sublots to be placed, sequencing of density testing, and other sampling and testing.

5-04.3(15) Sealing Pavement Surfaces

Apply a fog seal where shown in the plans. Construct the fog seal in accordance with Section 5-02.3. Unless otherwise approved by the Engineer, apply the fog seal prior to opening to traffic.

5-04.3(16) HMA Road Approaches

HMA approaches shall be constructed at the locations shown in the Plans or where staked by the Engineer. The Work shall be performed in accordance with Section 5-04.

5-04.3(17) Temporary Asphalt Pavement

(December 1, 2021 CFW GSP)

Section 5-04.3(17) is a new section:

Temporary asphalt pavement shall be placed by the Contractor immediately upon the request of the Engineer for the maintenance of traffic during construction. These areas include: voids created by the removal of existing improvements (i.e. Traffic islands, curbs), providing paved access to private properties, and ramps for property access during cement concrete driveway approach construction. All temporary paving shall be approved by the Engineer before placement. Any areas of temporary pavement to be removed and replaced shall be approved by the Engineer beforehand. This work shall also include the removal of temporary asphalt concrete pavement in its entirety prior to final paving.

Hot Mix Asphalt Temporary Pavement: Hot mix asphalt will be used for any trench or pavement restoration within the traveled way. Whether temporary or permanent, saw cut and treat edges with CSS-1 asphalt emulsion and apply a minimum 3-inch pavement depth or match existing, whichever is greater. Also, fill voids created by the removal of existing traffic islands and curbing, paving over excavated roadway to temporary access to adjacent properties, and ramps for property access during concrete approach construction.

Cold Mix Asphalt Temporary Pavement: Cold mix asphalt is allowed for temporary paving outside the traveled way. The cold mix shall be approved by the Engineer and placed in a 2-inch minimum thickness. Placement of temporary pavement without prior approval of the Engineer shall be considered as a benefit of the Contractor and no cost to the owner. Any areas of temporary pavement to be removed and replaced require prior approval by the Engineer. This work shall include the removal of the temporary pavement prior to paving of final asphalt concrete pavement.

5-04.4 Measurement

HMA Cl. ____ PG ____, HMA for ____ Cl. ____ PG ____, and Commercial HMA will be measured by the ton in accordance with Section 1-09.2, with no deduction being made for the weight of asphalt binder, mineral filler, or any other component of the mixture. If the Contractor elects to remove and replace mix as allowed by Section 5-04.3(11), the material removed will not be measured.

Roadway cores will be measured per each for the number of cores taken.

Preparation of untreated roadway will be measured by the mile once along the centerline of the main line Roadway. No additional measurement will be made for ramps, Auxiliary Lanes, service roads, Frontage Roads, or Shoulders. Measurement will be to the nearest 0.01 mile.

Soil residual herbicide will be measured by the mile for the stated width to the nearest 0.01 mile or by the square yard, whichever is designated in the Proposal.

Pavement repair excavation will be measured by the square yard of surface marked prior to excavation.

Asphalt for prime coat will be measured by the ton in accordance with Section 1-09.2.

Prime coat aggregate will be measured by the cubic yard, truck measure, or by the ton, whichever is designated in the Proposal.

Asphalt for fog seal will be measured by the ton, as provided in Section 5-02.4.

Longitudinal joint seals between the HMA and cement concrete pavement will be measured by the linear foot along the line and slope of the completed joint seal.

Planing bituminous pavement will be measured by the square yard.

Temporary pavement marking will be measured by the linear foot as provided in Section 8-23.4.

Water will be measured by the M gallon as provided in Section 2-07.4.

(April 12, 2018 CFW GSP)

Section 5-04.4 is supplemented with the following:

Hot Mix Asphalt Temporary Pavement shall be measured by the ton of material actually placed, with no deduction being made for the weight of liquid asphalt, blending sand, mineral filler, or any other component of the mixture. Hot Mix Asphalt Temporary Pavement shall be paid under the "Temporary Pavement" bid item and shall include placement and compaction of hot mix asphalt, removal and disposal of temporary pavement.

Cold Mix Asphalt Temporary Pavement will not be measured and shall be considered incidental to other bid items.

5-04.5 Payment

Payment will be made for each of the following Bid items that are included in the Proposal:

"HMA Cl. ___ PG ___", per ton.

"HMA for Approach Cl. ___ PG ___", per ton.

“HMA for Preleveling Cl. ____ PG ____”, per ton.

“HMA for Pavement Repair Cl. ____ PG ____”, per ton.

“Commercial HMA”, per ton.

The unit Contract price per ton for “HMA Cl. ____ PG ____”, “HMA for Approach Cl. ____ PG ____”, “HMA for Preleveling Cl. ____ PG ____”, “HMA for Pavement Repair Cl. ____ PG ____”, and “Commercial HMA” shall be full compensation for all costs, including anti-stripping additive, incurred to carry out the requirements of Section 5-04 except for those costs included in other items which are included in this Subsection and which are included in the Proposal.

“Preparation of Untreated Roadway”, per mile.

The unit Contract price per mile for “Preparation of Untreated Roadway” shall be full pay for all Work described under 5-04.3(4) , with the exception, however, that all costs involved in patching the Roadway prior to placement of HMA shall be included in the unit Contract price per ton for “HMA Cl. ____ PG ____” which was used for patching. If the Proposal does not include a Bid item for “Preparation of Untreated Roadway”, the Roadway shall be prepared as specified, but the Work shall be included in the Contract prices of the other items of Work.

“Preparation of Existing Paved Surfaces”, per mile.

The unit Contract Price for “Preparation of Existing Paved Surfaces” shall be full pay for all Work described under Section 5-04.3(4) with the exception, however, that all costs involved in patching the Roadway prior to placement of HMA shall be included in the unit Contract price per ton for “HMA Cl. ____ PG ____” which was used for patching. If the Proposal does not include a Bid item for “Preparation of Untreated Roadway”, the Roadway shall be prepared as specified, but the Work shall be included in the Contract prices of the other items of Work.

“Crack Sealing”, by force account.

“Crack Sealing” will be paid for by force account as specified in Section 1-09.6. For the purpose of providing a common Proposal for all Bidders, the Contracting Agency has entered an amount in the Proposal to become a part of the total Bid by the Contractor.

“Pavement Repair Excavation Incl. Haul”, per cubic yard.

The unit Contract price per cubic yard for “Pavement Repair Excavation Incl. Haul” shall be full payment for all costs incurred to perform the Work described in Section 5-04.3(4) with the exception, however, that all costs involved in the placement of HMA shall be included in the unit Contract price per ton for “HMA for Pavement Repair Cl. ____ PG ____”, per ton.

“Asphalt for Prime Coat”, per ton.

The unit Contract price per ton for “Asphalt for Prime Coat” shall be full payment for all costs incurred to obtain, provide and install the material in accordance with Section 5-04.3(4).

“Prime Coat Agg.”, per cubic yard, or per ton.

The unit Contract price per cubic yard or per ton for “Prime Coat Agg.” shall be full pay for furnishing, loading, and hauling aggregate to the place of deposit and spreading the aggregate in the quantities required by the Engineer.

“Asphalt for Fog Seal”, per ton.

Payment for “Asphalt for Fog Seal” is described in Section 5-02.5.

“Longitudinal Joint Seal”, per linear foot.

The unit Contract price per linear foot for “Longitudinal Joint Seal” shall be full payment for all costs incurred to perform the Work described in Section 5-04.3(12).

“Planing Bituminous Pavement”, per square yard.

The unit Contract price per square yard for “Planing Bituminous Pavement” shall be full payment for all costs incurred to perform the Work described in Section 5-04.3(14).

“Temporary Pavement Marking”, per linear foot.

Payment for “Temporary Pavement Marking” is described in Section 8-23.5.

“Water”, per M gallon.

Payment for “Water” is described in Section 2-07.5.

“Job Mix Compliance Price Adjustment”, by calculation.

“Job Mix Compliance Price Adjustment” will be calculated and paid for as described in Section 5-04.3(9)C6.

“Compaction Price Adjustment”, by calculation.

“Compaction Price Adjustment” will be calculated and paid for as described in Section 5-04.3(10)D3.

“Roadway Core”, per each.

The Contractor’s costs for all other Work associated with the coring (e.g., traffic control) shall be incidental and included within the unit Bid price per each and no additional payments will be made.

“Cyclic Density Price Adjustment”, by calculation.

“Cyclic Density Price Adjustment” will be calculated and paid for as described in Section 5-04.3(10)B.

(April 12, 2018 CFW GSP)

Section 5-04.5 is supplemented with the following:
“Temporary Pavement”, per ton.

(December 1, 2021 CFW GSP)

Section 5-04.5 is supplemented with the following:

The unit Contract price per ton for “HMA Cl. ___ PG ___”, “HMA for Approach Cl. ___ PG ___”, “HMA for Preleveling Cl. ___ PG ___”, “HMA for Pavement Repair Cl. ___ PG ___”, and “Commercial HMA” shall include compaction testing by the Contractor.

END OF DIVISION 5

DIVISION 8 MISCELLANEOUS CONSTRUCTION

8-01 EROSION CONTROL AND WATER POLLUTION CONTROL

8-01.3 Construction Requirements

8.01.3(1) General

(April 12, 2018 CFW GSP)

The first paragraph of 8-01.3(1) is deleted and replaced with the following:

The Contractor shall install a high visibility fence along the right-of-way lines shown in the Plans or as instructed by the Engineer.

8-01.3(1)A Submittals

(April 12, 2018 CFW GSP)

Section 8-01.3(1)A is revised to read:

A Stormwater Pollution Prevention Plan (SWPPP) shall be prepared by the Contractor and submitted for approval to the Engineer. The plan shall consist of the Contractor's complete strategy to meet the requirements of the Department of Ecology's NPDES and State Waste Discharge General Permit for Stormwater Discharges Associated With Construction Activity (General Permit). The SWPPP shall include and modify as necessary the Site Preparation and Erosion Control Plan drawings provided as part of the Contract Plans. The Contractor shall prepare review and modify the SWPPP as necessary to be consistent with the actual work schedule, sequencing, and construction methods that will be used on the project. The Contractor's SWPPP shall meet the requirements of the general permit. The Contractor's modifications to the SWPPP shall also incorporate the content and requirements for the Spill Prevention, Control and Countermeasures (SPCC) Plan in accordance with Section 1-07.15(1).

The SWPPP shall document all the erosion and sediment control Best Management Practices (BMPs) proposed, whether permanent or temporary. The plan shall document installation procedures, materials, scheduling, and maintenance procedures for each erosion and sediment control BMP. The Contractor shall submit the SWPPP for the Engineer's approval before any work begins. The Contractor shall allow at least five working days for the Engineer's review of the initial SWPPP or any revisions to the modified SWPPP. Failure to approve all or part of any such plan shall not make the Contracting Agency liable to the Contractor for any work delays. The Contractor may not begin work without an approved Contractor's SWPPP.

The Contractor shall complete and modify the SWPPP to meet the Contractor's schedule and method of construction. All TESC Plans shall meet the requirements of the current edition of the WSDOT Temporary Erosion and Sediment Control Manual M 3109 and be adapted as needed throughout construction based on site inspections and discharge samples to maintain compliance with the CSWGP. The Contractor shall develop a schedule for implementation of the SWPPP work and incorporate it into the Contractor's progress schedule.

In addition, the SWPPP shall outline the procedures to be used to prevent high pH stormwater or dewatering water from entering surface waters. The plan shall include how the pH of the water will be maintained between pH 6.5 and pH 8.5 prior to being discharged from the project or entering surface waters. Prior to beginning any concrete or grinding work, the Contractor shall submit the plan, for the Engineer's review and approval.

As a minimum, the SWPPP shall include all the SWPPP requirements identified in the General Permit, including:

Narrative discussing and justifying erosion control decisions (12 elements)

Drawings illustrating BMPs types and locations

Engineering calculations for ponds and vaults used for erosion control

A schedule for phased installation and removal of the proposed BMPs, including:

- A. BMPs that will be installed at the beginning of project startup.
- B. BMPs that will be installed at the beginning of each construction season.
- C. BMPs that will be installed at the end of each construction season.
- D. BMPs that will be removed at the end of each construction season.
- E. BMPs that will be removed upon completion of the project.

An Ecology template is available to the Contractor for producing the SWPPP, using project- specific information added by the Contractor. The template and instructions are available at:

<http://www.ecy.wa.gov/programs/wq/stormwater/construction/>

Turbidity and pH Exceedances

Following any exceedances of the turbidity or pH benchmarks, the Contractor shall provide the following at no additional cost to the Contracting agency:

1. The necessary SWPPP revisions and on-site measures/revisions including additional source control, BMP maintenance, and/or additional stormwater treatment BMPs that are necessary to prevent continued exceedance of turbidity and/or pH benchmarks.
2. The regulatory notification to the Dept. of Ecology and to the Engineer of any monitoring results requiring regulatory notification.
3. The additional daily sampling and reporting measures described in the General Permit to verify when project site runoff is in compliance.

8-01.3(1)B Erosion and Sediment Control (ESC) Lead ***(October 3, 2022 WSDOT GSP, OPTION 1)***

Item number 3 and 4 in the second paragraph of Section 8-01.3(1)B are revised to read:

3. Submit to the Engineer no later than the end of the next working day following the inspection a TESC Inspection Report that includes:
 - a. When, where, and how BMPs were installed, maintained, modified, and removed.
 - b. Observations of BMP effectiveness and proper placement.
 - c. Recommendations for improving future BMP performance with upgraded or replacement BMPs when inspections reveal TESC BMP deficiencies.
 - d. Identify for each discharge point location whether there is compliance with state water quality standards in WAC 173-201A for turbidity and pH.

8-01.3(2) Seeding, Fertilizing, and Mulching

8-01.3(2)B Seeding and Fertilizing (September 3, 2019 WSDOT GSP, OPTION 3)

Section 8-01.3(2)B is supplemented with the following:

Grass seed shall be a commercially prepared mix, made up of low growing species which will grow without irrigation at the project location, and approved by the Engineer. The application rate shall be two pounds per 1000 square feet. Fertilizer shall be a commercially prepared mix of 10-20-20 and shall be applied at the rate of 10 pounds per 1000 square feet.

8-02 ROADSIDE RESTORATION

8-02.3 Construction Requirements

8-02.3(1) Responsibility During Construction (April 12, 2018 CFW GSP)

Section 8-02.3(1) is supplemented with the following:

Landscape construction is anticipated to begin after all curbs, sidewalks, walls, and associated roadside work is completed. Landscape materials shall not be installed until weather permits and installation has been authorized by the Engineer. If water restrictions are anticipated or in force, planting of landscape materials may be delayed.

Throughout planting operations, the Contractor shall keep the premises clean, free of excess soils, plants, and other materials, including refuse and debris, resulting from the Contractor's work. At the end of each work day, and as each planting area is completed, it shall be neatly dressed, and all surrounding walks and paved areas shall be cleaned to the satisfaction of the Engineer. No flushing will be allowed. At the conclusion of work, the Contractor shall remove surplus soils, materials, and debris from the construction site and shall leave the project in a condition acceptable to the Engineer.

8-02.3(5) Planting Area Preparation (April 12, 2018 CFW GSP)

Section 8-02.3(5) is supplemented with the following:

Thoroughly scarify subgrade in tree, and seeded lawn areas to a minimum depth of six-inches (6") except within critical root zones of existing trees to remain, as noted on plans. Scarified subgrade shall be inspected and approved by the Engineer prior to the placement of topsoil. Remove all construction debris and rocks over two-inches (2") in diameter prior to placing topsoil.

Scarified subgrade shall be inspected and approved by the Engineer prior to placement of topsoil. Upon approval of the subgrade, Topsoil A shall be installed to a minimum depth of 4 inches lightly compacted depth in all seeded areas, unless otherwise noted on plans.

Lightly compact soil and establish a smooth and uniform finished grade to allow to surface drainage and prevents ponding.

The areas shall be brought to a uniform grade, 1 inch, or the specified depth of mulch, below walks, curbs, junction and valve boxes, and driveways, unless otherwise specified.

The costs of removing all excess material and debris shall be considered incidental to and included in the unit contract prices of other items in this contract.

8-02.3(6)B Fertilizers

(September 3, 2019 WSDOT GSP, OPTION 3)

Section 8-02.3(6)B is supplemented with the following:

Fertilizer shall be a commercially prepared mix of 10-20-20 and shall be applied at the rate of 10 pounds per 1000 square feet.

8-02.3(8) Planting

(March 22, 2023 CFW GSP)

Section 8-02.3(8) is supplemented with the following:

All Topsoil Type A required to pit plant trees and bark mulch for topdressing, as specified in the plans, shall be considered incidental to and included in the unit contract price of the trees.

Use loosened and replaced compacted mineral native soil without organics under tree rootball. Use topsoil on sides of tree rootball only. Use full depth topsoil for shrubs.

Trees shall be handled by the rootball, not by the trunk. Burlap and wire shall remain intact until trees are set in their final positions within each planting pit.

Plant trees and shrubs upright and rotate in order to give the best appearance or relationship to adjacent plants, topography, and structures. Hold plant rigidly in position until topsoil has been backfilled and water settled free of voids and air pockets and tamped firmly around the ball or roots.

When the pit is backfilled halfway, place the specified quantity of fertilizer plant tablets and stakes as shown in the Plans. Evenly space the fertilizer tablets around the perimeter of, and immediately adjacent to the root system. Carefully place

water and compact planting topsoil, filling all voids. Tree root crowns to be 1” higher than finished grade to allow for settlement.

When the planting pit is three quarters backfilled, fill with water and allow water to soak away. Fill the pits with additional topsoil to finish grade and continue backfilling as detailed in the Plans. Water trees immediately after planting.

The contractor shall apply 3 inches of pea gravel flush with bottom of tree grates in tree wells per City Standard Detail 3-31.

8-02.3(9)B Seeding and Fertilizing
(September 3, 2019 WSDOT GSP, OPTION 2)

Section 8-02.3(9)B is supplemented with the following:

Grass seed shall be a commercially prepared mix, made up of low growing species which will grow without irrigation at the project location, and accepted by the Engineer. The application rate shall be two pounds per 1000 square feet.

8-02.3(10) Fertilizer
(April 12, 2018 CFW GSP)

Section 8-02.3(10) is supplemented with the following:

All fertilizers shall be furnished in standard unopened containers with weight, name of plant nutrients and manufacturer’s guaranteed statement of analysis clearly marked, in accordance with State and Federal law.

Seeded areas, trees, and shrubs shall be fertilized at a rate according to fertilizer manufacturer’s recommendations.

8-02.3(11) Bark or Wood Chip Mulch
(March 22, 2023 CFW GSP)

Section 8-02.3(11) is supplemented with the following:

Bark Mulch shall be placed over all tree planting pits to a depth no less than two (2) inches, or as detailed in the Plans. Thoroughly water and hose down plants with a fine spray to wash the leaves of the plants immediately after application.

8-02.3(17) Protection of Private Property and Property Restoration
(March 22, 2023 CFW GSP)

Section 8-02.3(17) is a new section:

Property Restoration shall consist of fine grading and restoration of adjacent landscaped areas; adjustment and/or replacement of private irrigation systems; slope restoration behind sidewalks; timber edgings; installing and replacing private wood and chain link fencing; and other work not currently identified in the plans, as directed by the Engineer.

The Contractor is specifically reminded that any unnecessary damage caused by construction activities will be repaired at the Contractor’s expense.

Restore all disturbed areas to original condition or better. Grass areas shall be restored with hydroseed where directed.

Removal of tree roots outside the limits of construction, as directed by the Engineer and under the supervision of a certified arborist, shall be paid for under “Property Restoration”.

Topsoil shall be Type A and mulch shall be Bark or Wood Chip Mulch, per these Special Provisions.

All materials shall conform to Sections 9-14 Erosion Control and Roadside Planting and 9-15 Irrigation System of the Standard Specifications.

The force account provided for property restoration also includes any adjustments and/or replacements of existing irrigation systems not covered under Section 8-03 Irrigation Systems of the Special Provisions. This work shall also consist of modifying existing landscape lighting systems as may become necessary by these improvements.

The Contractor is advised that protecting existing private irrigation and lighting systems from damage does not constitute a basis for claim or extra work.

8-02.4 Measurement
(April 12, 2018 CFW GSP)

Section 8-02.4 is supplemented with the following:

“Property Restoration” will be paid by force account and must be approved by the engineer prior to completing the work.

8-02.5 Payment
(April 12, 2018 CFW GSP)

Section 8-02.5 is supplemented with the following

“Property Restoration” per force account.

8-04 CURBS, GUTTERS, AND SPILLWAYS

8-04.3 Construction Requirements
(March 22, 2023 CFW GSP)

Section 8-04.3 is supplemented with the following:

The sub-base for curb and gutter sections shall be compacted to 95 percent density at or below optimum moisture content, as per Section 2-03.3(14)D revised, before placing the curb and gutter.

White-pigmented curing compounds will not be allowed.

The top of the finished concrete shall not deviate more than one-eighth (1/8”) in ten feet (10’) or the alignment one-fourth (1/4”) in ten feet (10’).

Where shown in the Plans, the concrete curb will be ramped for wheel chairs as shown in the City Standard Plan Details.

Where shown in the plans, the Contractor shall paint the curbs with 2-coats of yellow paint. Paint and application shall conform to the Standard Specifications for traffic paint striping.

8-04.3(1) Cement Concrete Curbs, Gutters, and Spillways
(December 16, 2022 CFW GSP)

Section 8-04.3(1) is supplemented with the following:

The concrete class requirements in paragraph one are applicable for Type I/II Portland cement. See Section 9.01.2(1)B for requirements for Type 1L cement.

8-04.4 Measurement
(April 12, 2018 CFW GSP)

Section 8-04.4 is supplemented with the following:

Painting of curbs, where required, will not be measured and is considered incidental to the unit price of the type of curb.

8-06 CEMENT CONCRETE DRIVEWAY ENTRANCES

8-06.3 Construction Requirements
(December 16, 2022 CFW GSP)

Section 8-06.3 is supplemented with the following:

The concrete class requirements in paragraph one are applicable for Type I/II Portland cement. See Section 9.01.2(1)B for requirements for Type 1L cement.

All driveways shall remain open except as necessary to permit curing of construction materials or for short periods of time as required for excavations. However, at least one (1) driveway per parcel shall remain open to vehicular traffic at all times unless otherwise approved by the Engineer and affected property owner in writing. If a parcel has only one driveway, then that driveway must be constructed one-half at a time to allow the passage of vehicles. The amount of time that a driveway can be closed will be limited. To meet these requirements, the Contractor may use a quick setting concrete. The Engineer shall approve the quick-setting mix prior to use.

Property owners shall be notified in writing at least 48 hours in advance of any planned driveway closures

Crushed rock may be used, with Engineer approval, to maintain a driving surface.

8-06.5 Payment
(April 12, 2018 CFW GSP)

Section 8-06.5 is supplemented with the following:

If the Contractor chooses to use a quick-setting concrete mix for driveway construction, any additional costs to use such mix shall be incidental to the bid item for "Cement Conc. Driveway" and no additional payment will be made.

If the Contractor chooses to use crushed rock to maintain a driveway surface, it shall be incidental to the bid item for "Cement Conc. Driveway" and no additional payment shall be made.

8-14 CEMENT CONCRETE SIDEWALKS

8-14.2 Materials

(December 16, 2022 CFW GSP)

Section 8-14.2 is supplemented with the following:

The Cement Concrete Sidewalk and curb ramps shall be constructed of Class 4000 concrete or greater if Type I/II Portland cement is used. If Type 1L Blended hydraulic cement is used, see 9-01.2(1)B.

Pervious Cement Concrete

Concrete Mix Design: The Contractor shall submit a proposed mix design for the pervious cement concrete, with proportions of materials, to the Engineer 7 working days prior to commencement of work. ACI 522R-10 shall be used to determine mix design proportions. The data for the mix design shall include fresh density of the proposed pervious concrete mixture as determined in accordance with AASHTO T 19M/T 19 paragraph 11, jiggling procedure.

Concrete Mix Design Criteria

- The cementitious content, including pozzolans if used, shall be between 450 and 550 pounds per cubic yard.
- Total void content shall be greater than 15 percent and less than 25 percent, as measured by ASTM C 1688.
- The water/cementitious material ratio, by weight, shall be between 0.27 and 0.35.
- Cement: Portland Cement Type I or II conforming to ASTM C 150, Portland Cement Type IP or IS conforming to ASTM C 595, or Portland Cement Type IL conforming to Section 9-01.
- Aggregate: Use crushed gravel, stone meeting No. 8 coarse aggregate or No. 89 coarse aggregate per ASTM D 448. If other gradation of aggregate is to be used, submit data on proposed material to the Engineer for approval at least 7 working days prior to performing the work.
- Water: Comply with ASTM C 94

8-14.3 Construction Requirements

(December 16, 2022 CFW GSP)

Section 8-14.3 is supplemented with the following :

The concrete class requirements in paragraph one are applicable for Type I/II Portland cement. See Section 9.01.2(1)B for requirements for Type 1L cement.

(April 3, 2017 WSDOT GSP, OPTION 1)

Section 8-14.3 is supplemented with the following :

The Contractor shall request a pre-meeting with the Engineer to be held 2 to 5 working days before any work can start on cement concrete sidewalks, curb ramps or other pedestrian access routes to discuss construction requirements. Those attending shall include:

1. The Contractor and Subcontractor in charge of constructing forms, and placing, and finishing the cement concrete.
2. Engineer (or representative) and Project Inspectors for the cement concrete sidewalk, curb ramp or pedestrian access route Work.

CITY OF FEDERAL WAY

**ON-CALL SIDEWALK AND CURB
REPLACEMENT
PROJECT #101-2023A**

SP-91

Items to be discussed in this meeting shall include, at a minimum, the following:

1. Slopes shown on the Plans
2. Inspection
3. Traffic control
4. Pedestrian control, access routes and delineation
5. Accommodating utilities
6. Form work
7. Installation of detectable warning surfaces
8. Contractor ADA survey and ADA Feature as-built requirements
9. Cold Weather Protection

(January 7, 2019 WSDOT GSP, OPTION 2)

Section 8-14.3 is supplemented with the following:

Timing Restrictions

Curb ramps shall be constructed on one leg of the intersection at a time. The curb ramps shall be completed and open to traffic within five calendar days before construction can begin on another leg of the intersection unless otherwise allowed by the Engineer.

Unless otherwise allowed by the Engineer, the five calendar day time restriction begins when an existing curb ramp for the quadrant or traffic island/median is closed to pedestrian use and ends when the quadrant or traffic island/median is fully functional and open for pedestrian access.

(January 7, 2019 WSDOT GSP, OPTION 3)

Section 8-14.3 is supplemented with the following:

Layout and Conformance to Grades

Using the information provided in the Contract documents, the Contractor shall layout, grade, and form each new curb ramp, sidewalk, and curb and gutter.

(March 22, 2023 CFW GSP)

Section 8-14.3 is supplemented with the following :

Cement concrete sidewalk thickness shall be as shown in the Plans. Score joints shall be constructed at a maximum distance of 5 feet from each full depth expansion joint, except where specific dimensions are detailed in the Plans. Asphalt mastic joint fillers in the sidewalk shall be 3/8" x 4" and of the same material as that used in the curb, and shall be placed in the same location as that in the curb.

No concrete for sidewalk shall be poured against dry forms or dry subgrade.

The Contractor may provide suitable vibrating finishers for use in finishing concrete sidewalks. The type of vibrator and its method of use shall be subject to the approval of the City.

All completed work shall be so barricaded as to prevent damage. Any damaged sections shall be removed and replaced at the Contractor's expense. Landscaped areas disturbed during construction shall be restored to original condition at the Contractor's expense.

Scored Cement Concrete Sidewalk shall be broom finished and scored as detailed in the Plans.

(April 12, 2018 CFW GSP)

Section 8-14.3 is supplemented with the following :

Pervious Cement Concrete Sidewalk

Mix Time: Truck mixers shall be operated at the speed designated as mixing speed by the manufacturer for 75 to 100 revolutions of the drum.

Transportation: The portland cement aggregate mixture may be transported or mixed on site and should be placed within one (1) hour of the introduction of mix water. This time can be increased to 90 minutes when utilizing a hydration stabilizer.

Water may only be added by the concrete producer to obtain the required mix consistency. A minimum of 20 revolutions at the manufacturer's designated mixing speed shall be required following any addition of water to the mix.

Jointing: Control (contraction) joints shall be installed normally at 12 foot to 15 foot intervals, a maximum of 15 foot intervals is allowed. Control joints shall be located so as to match the joints in the curb and gutter, whether the pervious concrete sidewalk is adjacent to the curb or separated by a planter strip. They shall be installed at a depth of $\frac{1}{4}$ the thickness of the sidewalk. These joints can be installed in the plastic concrete with a rolling joint tool designed specifically for this purpose or saw cut (with prior approval of Engineer). Sawcutting is not the preferred joint method. If saw cut, the procedure should begin as soon as the sidewalk has hardened sufficiently to prevent raveling and uncontrolled cracking (normally after curing). Transverse construction joints shall be installed whenever placing is suspended a sufficient length of time that concrete may begin to harden. In order to assure aggregate bond at construction joints, a bonding agent suitable for bonding fresh concrete to existing concrete shall be brushed, rolled or sprayed on the existing sidewalk surface edge. Isolation (expansion) joints will not be used except when sidewalk is abutting slabs or other adjoining structures.

Placing and Finishing Equipment: Unless otherwise approved by the Engineer in writing, the Contractor shall provide mechanical equipment of either slip form or form riding with a following compactive unit that will provide a minimum of 10 psi vertical force. The pervious concrete sidewalk will be placed to the required cross section and shall not deviate more than +/- 3/8 inch in 10 feet from profile grade. If placing equipment does not provide the minimum specified vertical force, a full width roller or other full width compaction device that provides sufficient compactive effort shall be used immediately following the strike-off operation. After mechanical or other approved strike-off and compaction operation, no other finishing operation will be allowed. If vibration, internal or surface applied, is used, it shall be shut off immediately when forward progress is halted for any reason. The Contractor will be restricted to sidewalk placement widths of a maximum of fifteen (15') feet unless the Contractor can demonstrate competence to

provide sidewalk placement widths greater than the maximum specified to the satisfaction of the Engineer.

Curing: Curing procedures shall begin immediately after the final placement operations. The pavement surface shall be covered with a minimum of (6) mil thick polyethylene sheet or other approved covering material. Prior to covering, a fog shall be sprayed above the surface when required due to ambient conditions. The cover shall overlap all exposed edges and shall be secured to prevent dislocation due to wind or adjacent traffic conditions. Cure sidewalk for a minimum of 7 days, unless otherwise specified.

Testing and Acceptance of Pervious Cement Concrete Sidewalk

Test Panels: The Contractor shall place, joint and cure one test panel, each to be a minimum of 50 square feet at the project site to demonstrate to Engineer's satisfaction that a satisfactory sidewalk can be installed at the location. If the test panel meets Engineer's approval for aesthetics and pressure wash testing, it can be left in-place and included in the completed work. If the requirements mentioned above are not met, the test panel shall be removed at the Contractor's expense and disposed of in an approved landfill.

Pervious Concrete Void Structure: The Pervious Concrete Void Structure shall be tested in accordance with ASTM C 1688 and shall be between 15 and 25 percent.

Unit Weight: The Contractor shall test, in accordance with WAQTC TM 2 and AASHTO T 121, at least one sample for each day's placement of pervious cement concrete to verify unit weight. Delivered unit weights shall be determined in accordance with AASHTO T 121. The measure shall be filled and compacted in accordance with AASHTO T 19M/T 19 paragraph 11, jigging procedure. The unit weight of the concrete shall be +/- 5 pcf of the design unit weight.

Pressure Wash Testing: The Contractor shall pressure wash the pervious concrete sidewalk using a washer working at a minimum of 3,000 psi and 1.0 gpm. The nozzle shall be held a maximum of 3 inches off the concrete. The Contractor shall wash the entire top surface of the pervious concrete sidewalk. Sections of pervious concrete that breaks up, pits or does not infiltrate shall be removed and replaced, at no cost to the Contracting Agency.

8-14.3(5)C Surface Applied Detectable Warning Surface ***(December 16, 2022 CFW GSP)***

Section 8-14.3(5)C is replaced with the following :

Glued or stick down Detectable Warning Surfaces are allowed on asphalt surfaces only for temporary work zone applications.

MMA-Style Truncated Dome Detectable Warning Surfaces applied to asphalt surfaces for permanent installations shall be liquid-applied Vanguard ADA Systems, or approved equal.

8-14.5 Payment ***(April 12, 2018 CFW GSP)***

Section 8-14.5 is supplemented with the following:

CITY OF FEDERAL WAY

SP-94

**ON-CALL SIDEWALK AND CURB
REPLACEMENT
PROJECT #101-2023A**

Payment for “Cement Conc. Curb Ramp Type _____” will not be made until the City has verified that the ramp(s) meet ADA requirements.

“Pervious Cement Concrete Sidewalk”, per square yard.

“Thickened Edge Sidewalk” per linear foot. Payment for “Thickened Edge Sidewalk” will be made in addition to any payment per square yard for “Cement Conc. Sidewalk.”

END OF DIVISION 8

DIVISION 9 MATERIALS

9-01 CONCRETE

9-01.2 Specifications

9-01.2(1)B Blended Hydraulic Cement *(December 16, 2022 CFW GSP)*

Section 9-01.2(1)B is modified with the following:

Type 1L cement is only allowed for use within the City of Federal Way subject to the conditions listed below:

	Class 3000 Type 1L	Class 4000 Type 1L	Class 4000 Type 1L with crystalline waterproofing and corrosion protection admixture ¹	Class 5000 Type 1L
Pre-cast Foundations <i>(luminaires, signals, RRFBs, etc.)</i>	X	X	X	X
Cast-in-Place Foundations <i>(luminaires, signals, RRFBs, etc.)</i>		X	X	X
Pre-cast or cast-in-place catch basins and manholes		X	X	X
Roads, curbs, curb & gutters, roundabouts & aprons, sidewalks, ADA ramps, driveway approaches			X	X
Other exposed surfaces <i>(retaining walls, junction box aprons, cabinet bases, barriers, etc.)</i>			X	X

¹ *Crystalline Waterproofing admixtures (Penetron or approved equal) shall meet the following specification: ASTM C494, Type S, hydrophilic, crystalline permeability-reducing admixture for hydrostatic conditions (PRAH) shall form insoluble crystals throughout the concrete matrix, self-healing and sealing all pores, capillaries and cracks up to 0.5mm (1/51 inch). The crystalline waterproofing admixture shall include a colored tracer material so that it is visible when included in the concrete mix.*

For all Type 1L concrete mixes, the City will not accept any maleated rosin (i.e. MasterAir AE90) as a supplied air entrainment and waterproofing admixture or any wax-based curing compounds.

9-03 AGGREGATES

9-03.12 Gravel Backfill

CITY OF FEDERAL WAY

**ON-CALL SIDEWALK AND CURB
REPLACEMENT
PROJECT #101-2023A**

SP-96

9-03.12(6) Pit Run Sand
(April 12, 2018 CFW GSP)

Section 9-03.12(6) is a new section:

<u>Sieve Size</u>	<u>Percent Passing</u>
3/8" square	100
U.S. No. 4	90
Sand Equivalent	30 minimum

9-03.14(3) Common Borrow
(April 12, 2018 CFW GSP)

Section 9-03.14(3) is modified with the following requirements:

Material from on-site excavations meeting the requirements for Common Borrow shall be used to the extent practicable. Material for common borrow shall consist of granular soil and/or aggregate which is free of trash, wood, debris, and other deleterious material.

Common Borrow material shall be at the proper moisture content for compaction. This material is generally moisture sensitive. The natural moisture content shall range from not more than 1 percent wet of optimum to not more than 3 percent dry of optimum as determined in accordance with Section 2-03.3(14)D. The material shall not pump or yield under the weight of compaction equipment and construction traffic. The Contractor is responsible for protecting the material from excess moisture wherever/whenever possible. To the extent practicable, this material should be handled only during non-rainy periods and should be removed, hauled, placed, and compacted into final embankments without intermediate handling or stockpiling. Surfaces should be graded and sloped to drain and should not be left uncompacted.

Common Borrow shall meet the following gradation limits:

Sieve Size	Percent Passing (by weight)
6" square ¹	100
4" square	90 – 100
2" square	75 - 100
U.S. No. 4	50 - 80
U.S. No. 40	50 max.
U.S. No 200	25 max.

¹ For geosynthetic reinforced walls or slopes, 100percent passing 1¼-inch square sieve and 90 to 100 percent passing the 1-inch square sieve.

Common Borrow shall contain sufficient fines for compaction and to bind the compacted soil mass together to form a stable surface when heavy construction equipment is operated on its surface.

9-14 EROSION CONTROL AND ROADSIDE PLANTING

9-14.1 Materials Submittals and Acceptance
(January 10, 2022, WSDOT GSP, OPT1.2023)

In the table in Section 9-14.1, the row for Compost is revised to read:

CITY OF FEDERAL WAY

SP-97

ON-CALL SIDEWALK AND CURB
REPLACEMENT
PROJECT #101-2023A

9-14.5(8)	Compost	<p>Cert & following information is required to be submitted fourteen days prior to application.</p> <ul style="list-style-type: none"> a) A copy of the Solid Waste Handling Permit issued to the manufacturer by the Jurisdictional Health Department in accordance with https://apps.leg.wa.gov/WAC/default.aspx?cite=173-350 (Minimum Functions Standards for Solid Waste Handling). b) Compost Test Data submitted on WSDOT Form 220-038 that show the compost complies with the processes, testing, and standards specified in WAC 173-350 and this section. And independent Seal of Testing Assurance (STA) Program certified laboratory shall perform the testing within 90 calendar days of application. c) A copy of the manufacturer's annual Seal of Testing Assurance STA certification as issued by the U.S. Composting Council. d) A sample of the compost approved for use. e) A list of feed stocks by volume for each compost type. f) Compliance with the applicable section.
-----------	---------	-------------------------------------------------------------------------------------------------------------------------------------------------------------------------------------------------------------------------------------------------------------------------------------------------------------------------------------------------------------------------------------------------------------------------------------------------------------------------------------------------------------------------------------------------------------------------------------------------------------------------------------------------------------------------------------------------------------------------------------------------------------------------------------------------------------------------------------------------------------------------------------------------------------------------------------------------------------------------------------------------------------------------------------------------------------------------------------------------------------------------------------

9-14.2 Topsoil

9-14.2(1) Topsoil Type A
(June 12, 2020 CFW GSP)

Section 9-14.2(1) is supplemented with the following:

Topsoil Type A mix shall be 50% pure organic compost and 50% sand or sandy loam. The soil shall be high in organic content and comprised of fully composted and mature organic materials.

No fresh sawdust or other fresh wood by-products shall be added to extend the volume after the composting process.

Chemical and physical characteristics of Topsoil Type A shall comply with the following:

Screen Size	7/16" Maximum
Total Nitrogen	0.25% Minimum
Organic Matter	10% Minimum
pH Range	5.5 to 7.5
Conductivity	5 mmhos/cm Maximum

9-14.3 Seed
(June 12, 2020 CFW GSP)

Section 9-14.3 is supplemented with the following:

The grass seed dealer shall mix the grass seed only. The Contractor shall furnish the Engineer with a dealer's guaranteed statement of the composition, mixture, and the percentage of purity and germination of each variety. Seed shall be applied at

manufacturer's recommended rate. Hydroseed shall be composed of the following varieties mixed in the proportions indicated, or approved equal:

SEEDED LAWN MIXTURE			
NAME	BY WEIGHT	% PURITY	% GERMINATION
Tall Fescue / Festuca arundinacea	40%	98%	90%
Creeping Red Fescue / Festuca rubra	25%	98%	90%
Highland Colonial Bentgrass / Agrostis capillaris var. 'Highland'	5%	98%	90%
Perennial Rye / Lolium perenne (blend of two: 'Fiesta II', 'Prelude II', 'Commander')	30%	95%	90%

9-14.4 Fertilizer

(June 12, 2020 CFW GSP)

Section 9-14.4 is supplemented with the following:

Fertilizer for trees shall be biodegradable fertilizer packets, 20-10-5. Apply per manufacturer's recommendations.

9-14.5 Mulch and Amendments

9-14.5(3) Bark or Wood Chips

(June 12, 2020 CFW GSP)

Section 9-14.5(3) is supplemented with the following:

Bark or Wood Chip Mulch shall be medium grade composted ground fir or hemlock bark. The bark shall be uniform in color, free from weed seeds, sawdust and splinters. The moisture content of bagged mulch shall not exceed 22%. The acceptable size range of bark mulch material is ½" to 1" with maximum of 20% passing the ½" screen.

9-14.7 Plant Materials

9-14.7(2) Quality

(June 12, 2020 CFW GSP)

Section 9-14.7(2) is supplemented with the following:

Plant material shall be free from disfiguring knots, swollen grafts, sunscald injuries, bark abrasions, evidence of improper pruning or other objectionable disfigurement.

Potted and container stock shall be well rooted and vigorous enough to ensure survival and healthy growth. Shrubs shall have full foliage (not leggy). Container stock shall be grown in its delivery container for not less than six (6) months, but not for more than two (2) years. Root bound or broken containers will not be accepted. Bare root, liner and root stock with dried or shriveled roots from exposure will not be accepted.

Measurements, caliper, branching, grading, quality, balling and burlapping shall follow the Code of Standards of the American Associate of Nurserymen in the American Standard for Nursery Stock, ANSI 260.1, latest edition. Measurements shall be taken with all branches in their normal growing position. Plants shall not be pruned prior to delivery to site.

9-14.7(3) Handling and Shipping

(June 12, 2020 CFW GSP)

Section 9-14.7(3) is supplemented with the following:

Tie back branches as necessary, and protect bark from chafing with burlap bags. Do not drag Plant materials along ground without proper protection of roots and branches. Protect rootballs from environmental or mechanical damage and water as necessary to keep roots moist. Do not store Plants for more than one week.

9-14.7(4) Sod

(June 12, 2020 CFW GSP)

Section 9-14.7(4) is supplemented with the following:

Sod Lawn shall be three-way Tall Fescue Blend Sod, 33.33% Firecracker LS Tall Fescue, 33.33% Spyder LS Tall Fescue, 33.33% Raptor II Tall Fescue with degradable netting, or approved equal.

9-14.7(5) Tagging

(June 12, 2020 CFW GSP)

Section 9-14.7(5) is a new section::

All Plant material shall be legibly tagged. Tagging may be by species or variety with minimum of one tag per ten trees, shrubs, or vines. Remove all tagging prior to final acceptance.

9-14.7(6) Inspection

(June 12, 2020 CFW GSP)

Section 9-14.7(6) is a new section:

The Contracting Agency shall reserve the option of selecting and inspecting Plant material at the nursery. The contractor shall provide the Contracting Agency with at least one week notice prior to preparing Plants for shipping and delivery. The Contractor shall neither deliver to site nor install Plant materials until authorized by the Contracting Agency.

9-14.7(7) Temporary Storage

(June 12, 2020 CFW GSP)

Section 9-14.7(7) is a new section:

Cold storage of Plants shall not be permitted.

If Planting is delayed more than 24 hours after delivery, set balled and burlapped Plants on the ground, well protected with soil or wet peat. Adequately cover all roots of bare root material with soil or wet peat. Protect rootballs from freezing, sun, drying winds or mechanical damage. Water Plant material as necessary until Planted.

Plants shall not be stored for more than one week. Longer storage period at project site will result in rejection of Plant materials by the Contracting Agency.

9-14.8 Stakes, Guys, and Wrapping

(June 12, 2020 CFW GSP)

Section 9-14.8 is supplemented with the following:

Stakes shall be BVC round tree stakes with Chainlock guying or Engineer accepted product. No wrapping required.

9-14.9 Root Barrier

(June 12, 2020 CFW GSP)

Add the following new section:

Root Barrier shall be 18-inch high, minimum thickness 0.090-inch, interlocking root barrier panels constructed of high-impact polypropylene with 1/2-inch reinforcing ribs.

SECTION 9-19 DETECTABLE WARNING SURFACE

9-19.2 Cast-in-Place Detectable Warning Surface

9-19.2(1) General Requirements

(October 3, 2022 WSDOT GSP, OPTION 1)

The first paragraph of Section 9-19.2(1) is revised to read:

The color of detectable warning surfaces shall be yellow and shall match SAE AMS Standard 595, color number 33538 unless otherwise shown on the plans. When used in areas between ramps to differentiate between travel paths, detectable warning surfaces shall be black.

Units shall provide the required contrast (light-on-dark or dark-on-light) with the adjacent curb ramp or other applicable walkway.

END DIVISION 9

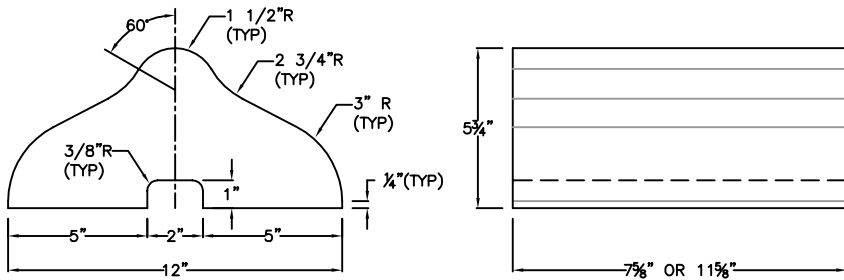

SECTION

ELEVATION

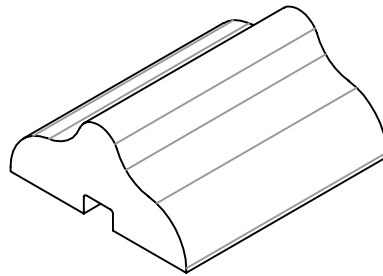

ISOMETRIC

TYPE 'C' BLOCK TRAFFIC CURB

NOTES:

1. SEE DWG. 3-3 FOR JOINT REQUIREMENTS.
2. ROLL GUTTER TO MATCH POSITIVE SUPERELEVATION.
3. TO BE USED ONLY AS APPROVED BY THE PUBLIC WORKS DEPT.

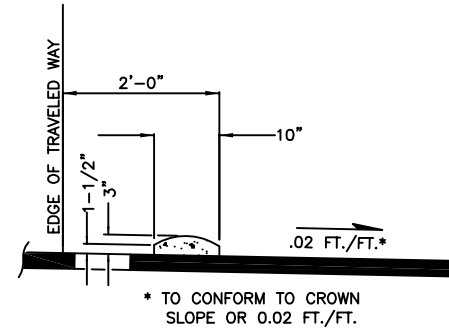

MOUNTABLE CEMENT CONCRETE CURB³

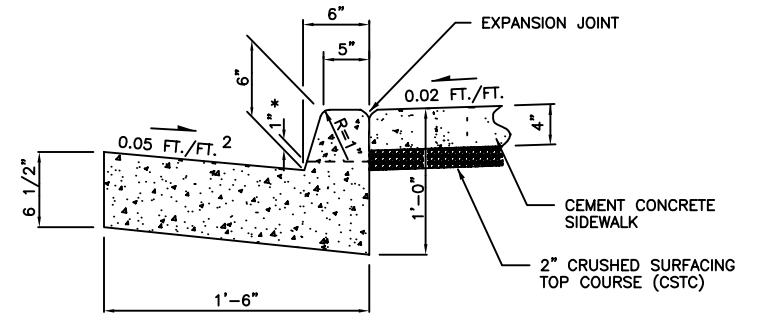

* NOTE: TOP OF LIP AT DRIVEWAYS.

NEW CEMENT CONCRETE CURB & GUTTER

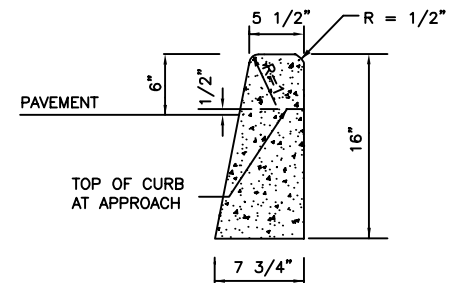

CEMENT CONCRETE BARRIER CURB

REV: FEB 2011

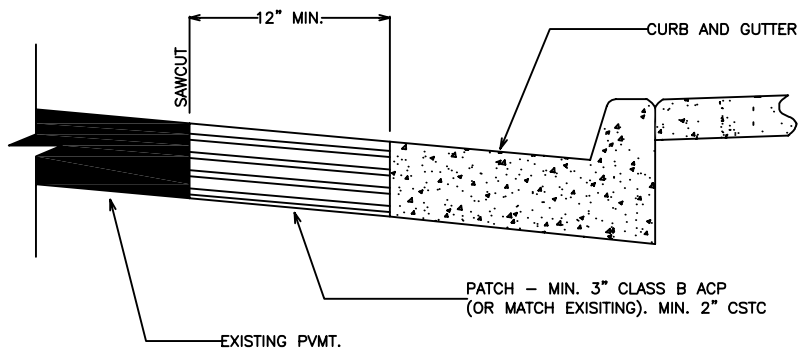

CEMENT CONCRETE CURB & GUTTER REPLACEMENT¹

NOTES:

- EXISTING CURB REPLACEMENT WILL REQUIRE REMOVAL OF ASPHALT A MINIMUM OF 12" FROM FACE OF GUTTER.

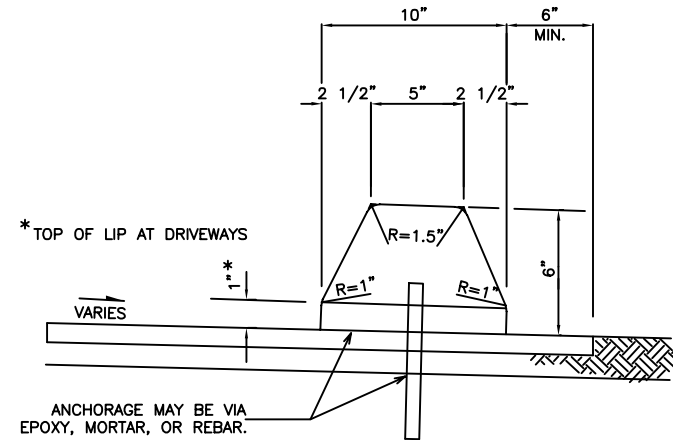

EXTRUDED ASPHALT OR CEMENT CONCRETE CURB
IN PRIVATE PARKING AREAS ONLY

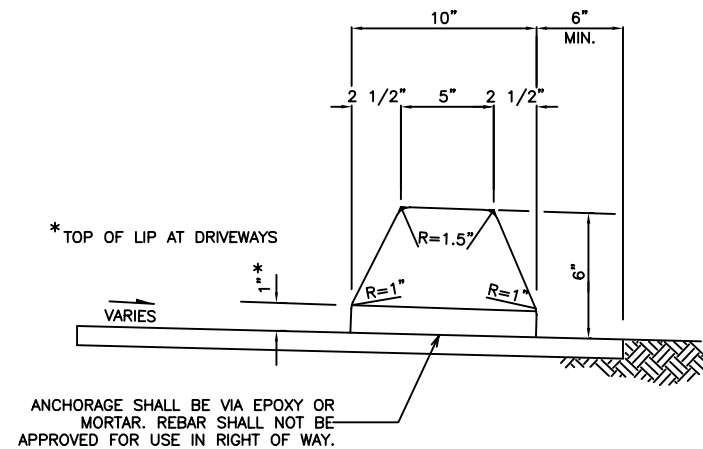

EXTRUDED CEMENT CONCRETE CURB
FOR USE IN PUBLIC RIGHT OF WAY

APRIL 2012

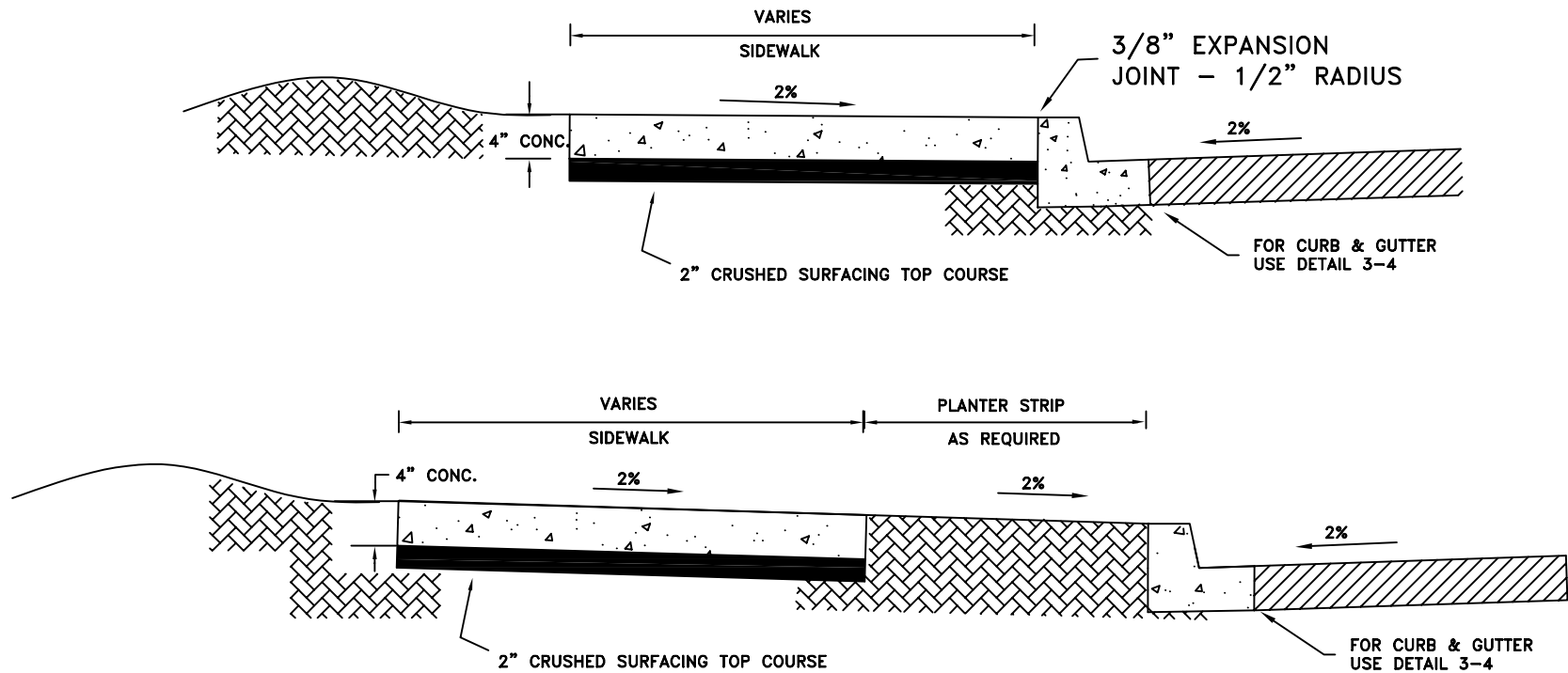

NOTES:

1. FOR JOINTS AND SCORING, SEE FEDERAL WAY STANDARD FOR SIDEWALK SPACING, EXPANSION JOINTS, AND SCORE MARKS.
2. SEE DETAILS 3-6, 3-6A, & 3-7 FOR MINIMUM DEPTH OF CONCRETE THROUGH DRIVEWAY SECTIONS.
3. WHEN CHECKED WITH A 10 FOOT STRAIGHTEDGE, GRADE SHALL NOT DEVIATE MORE THAN 1/8 INCH AND ALIGNMENT SHALL NOT VARY MORE THAN 1/4 INCH.
4. CONCRETE SHALL BE CLASS 3000, WSDOT SPEC. 8-14.

REV. MAR 2011

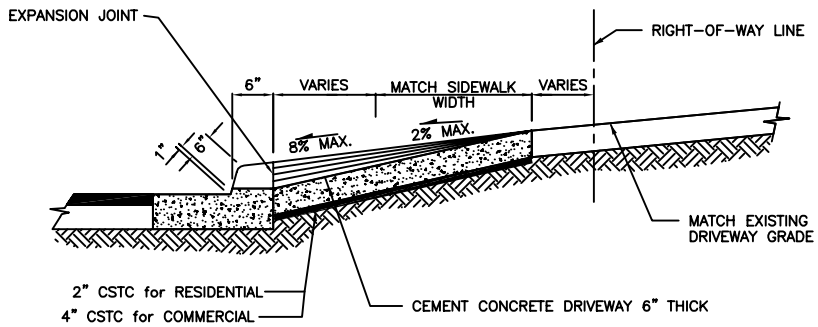
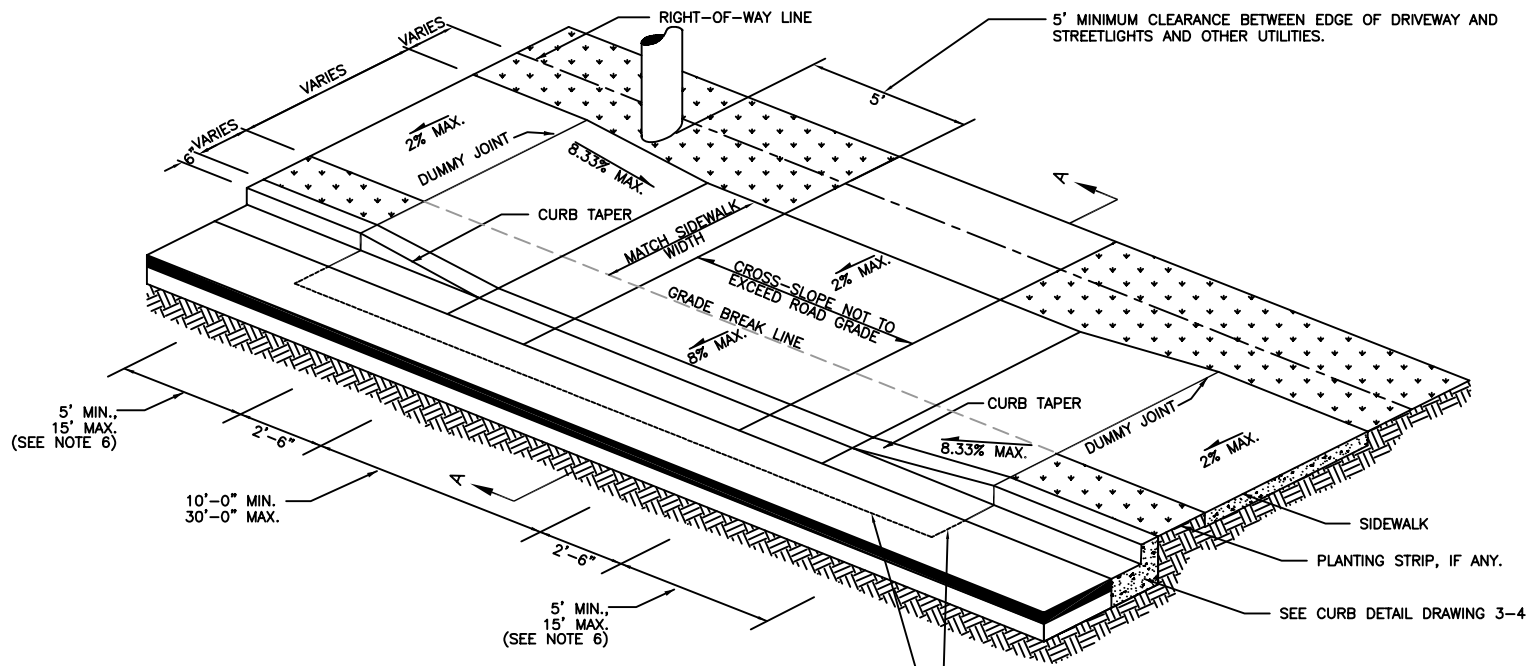

SECTION A-A

- NOTES:
1. REFER TO CITY STANDARD DETAIL DRAWING 3-6A FOR COMMERCIAL, INDUSTRIAL, OR MULTI-FAMILY USE DRIVEWAYS.
 2. SEE SEC. 3.2.13 AND CURB DETAIL DRAWING 3-4.
 3. CEMENT CONCRETE DRIVEWAY APPROACHES SHALL BE CONSTRUCTED WITH CEMENT CONC. CLASS 4000 WITH 4% TO 6% AIR ENTRAINMENT.
 4. FULL DEPTH EXPANSION JOINT IF DRIVEWAY WIDTH IS 15' OR GREATER.
 5. REFER TO SECTION 3.2.13 FOR DRIVEWAY SPACING.
 6. LENGTH OF RAMP SHALL VARY AS NEEDED TO MEET ADA SLOPE REQUIREMENTS.

REV. FEBRUARY 2014

DRAWN BY: FERN LIDDELL

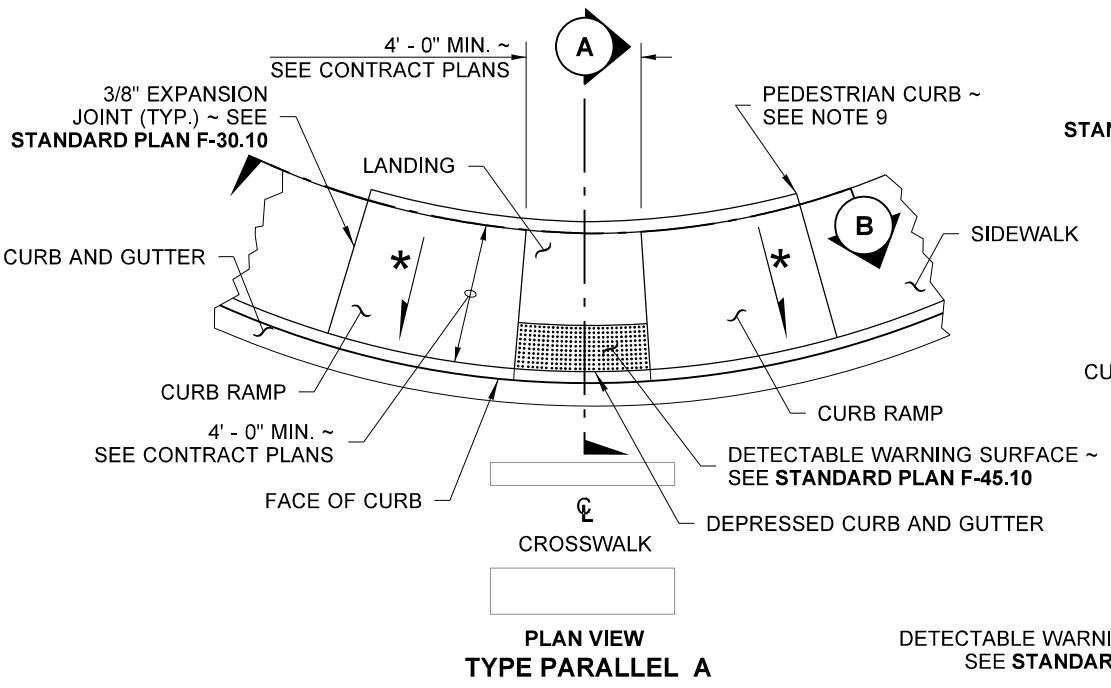

**PLAN VIEW
TYPE PARALLEL A**

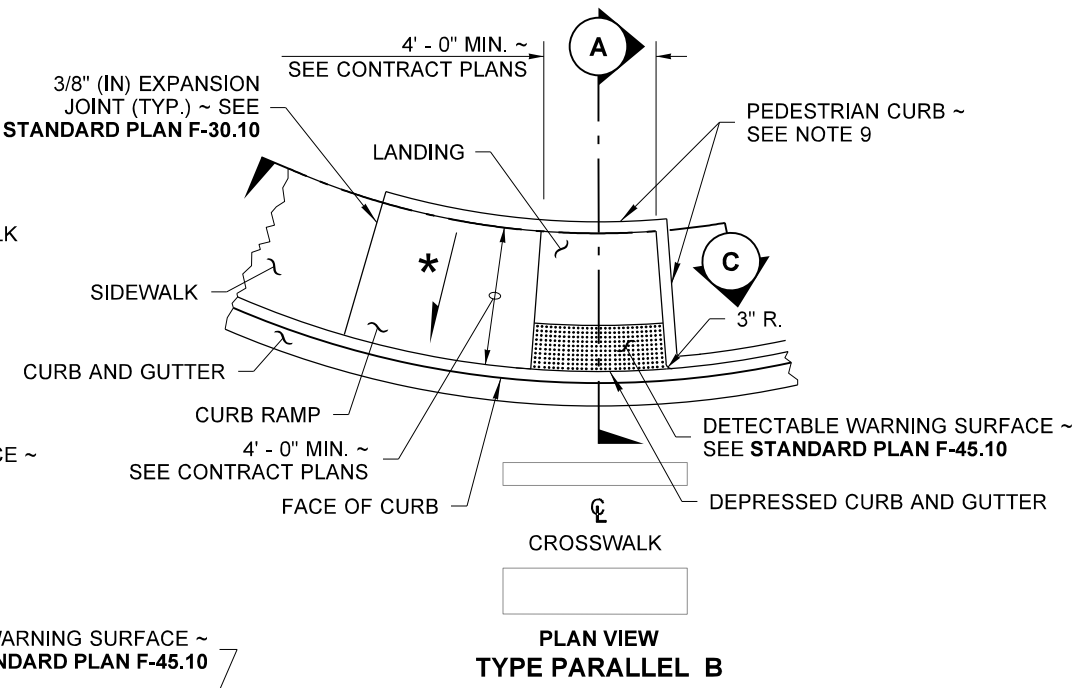

**PLAN VIEW
TYPE PARALLEL B**

1 CONTRACTION JOINT (TYP.) ~ SEE **STANDARD PLAN F-30.1** FOR CURB RAMP LENGTHS GREATER THAN 8' - 0" PROVIDE CONTRACTION JOINT EQUALLY SPACED 4' - 0" MIN. OC.

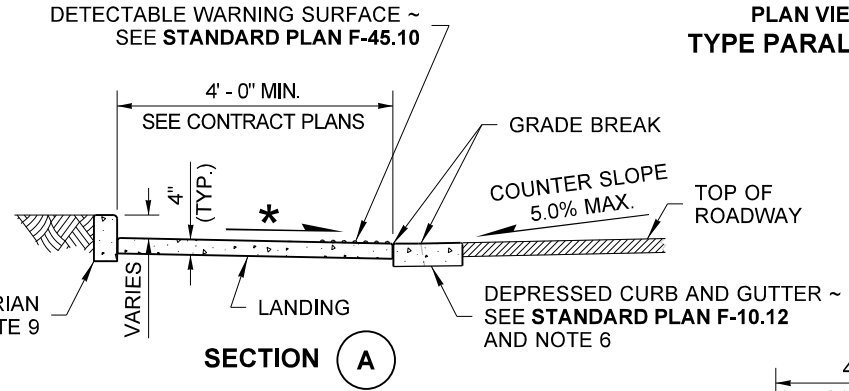

SECTION A

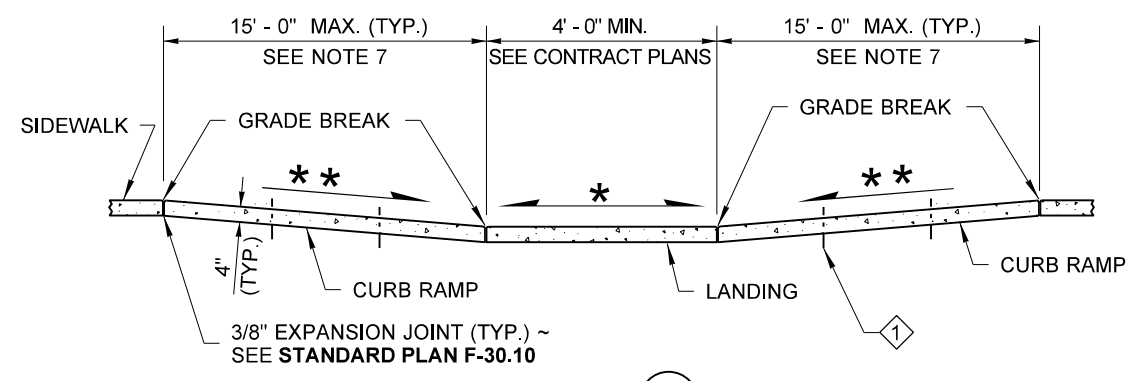

SECTION B
(ALONG INSIDE RADIUS AT BACK OF WALKWAY)

"CEMENT CONCRETE CURB RAMP TYPE PARALLEL A" PAY LIMIT ~ SEE NOTE 6

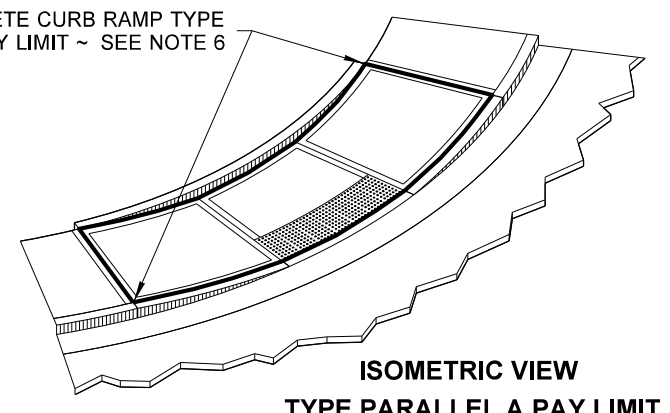

**ISOMETRIC VIEW
TYPE PARALLEL A PAY LIMIT**

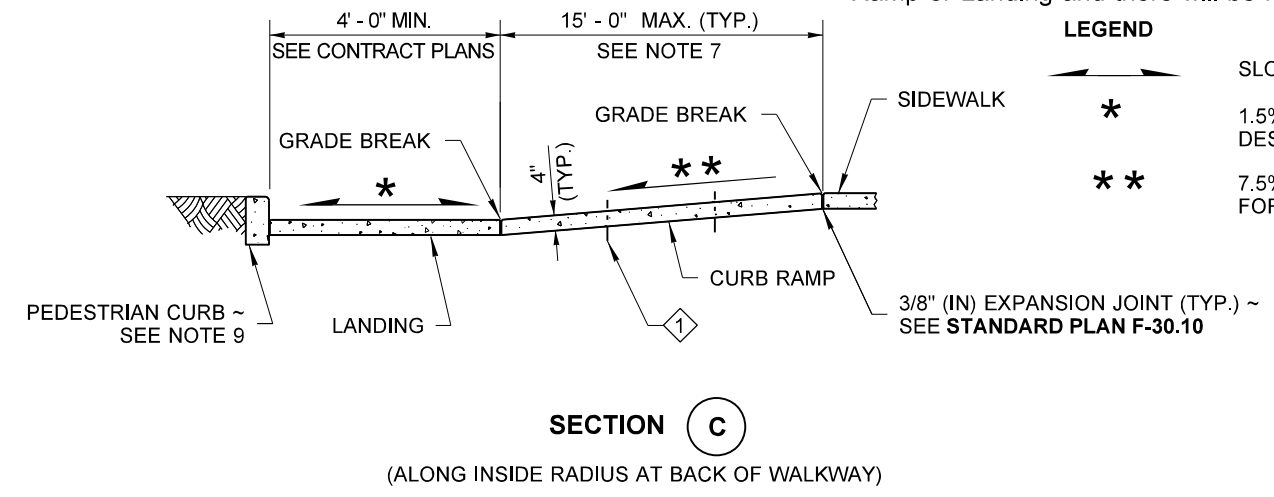

SECTION C
(ALONG INSIDE RADIUS AT BACK OF WALKWAY)

"CEMENT CONCRETE CURB RAMP TYPE PARALLEL B" PAY LIMIT ~ SEE NOTE 6

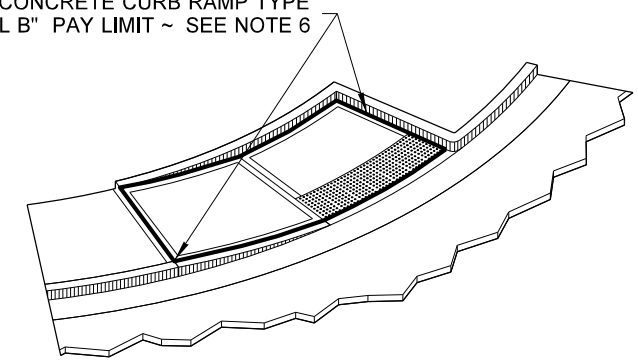

**ISOMETRIC VIEW
TYPE PARALLEL B PAY LIMIT**

NOTES

- At marked crosswalks, the connection between the landing and the roadway must be contained within the width of the crosswalk markings.
- Where "GRADE BREAK" is called out, the entire length of the grade break between the two adjacent surface planes shall be flush.
- Do not place Gratings, Junction Boxes, Access Covers, or other appurtenances on any part of the Curb Ramp or Landing, or in the Depressed Curb and Gutter where the Landing connects to the roadway.
- See Contract Plans for the curb design specified. See **Standard Plan F-10.12** for Curb, Curb and Gutter, Depressed Curb and Gutter, and Pedestrian Curb details.
- See **Standard Plan F-30.10** for Cement Concrete Sidewalk Details. See Contract Plans for width and placement of sidewalk.
- The Bid Item "Cement Concrete Curb Ramp Type ___" does not include the adjacent Curb, Curb and Gutter, Depressed Curb and Gutter, Pedestrian Curb, or Sidewalks.
- The Curb Ramp length is not required to exceed 15 feet (unless otherwise shown in the Contract Plans). When applying the 15-foot max. length, the running slope of the curb ramp is allowed to exceed 8.3%. Use a single constant slope from bottom of ramp to top of ramp to match into the sidewalk over a horizontal distance of 15 feet. Do not include abutting landing(s) in the 15-foot max. measurement. When a ramp is constructed on a radius, the 15-foot max. length is measured on the inside radius along the back of the walkway.
- Curb Ramps and Landings shall receive a broom finish. See **Standard Specifications 8-14**.
- Pedestrian Curb may be omitted if the ground surface at the back of the Curb Ramp and/or Landing will be at the same elevation as the Curb Ramp or Landing and there will be no material to retain.

LEGEND

- SLOPE IN EITHER DIRECTION
- 1.5% OR FLATTER RECOMMENDED FOR DESIGN/FORMWORK (2% MAX.)
- 7.5% OR FLATTER RECOMMENDED FOR DESIGN/FORMWORK (8.3% MAX.) ~ SEE NOTE 7



**PARALLEL CURB RAMP
STANDARD PLAN F-40.12-03**

SHEET 1 OF 1 SHEET

APPROVED FOR PUBLICATION



DRAWN BY: FERN LIDDELL

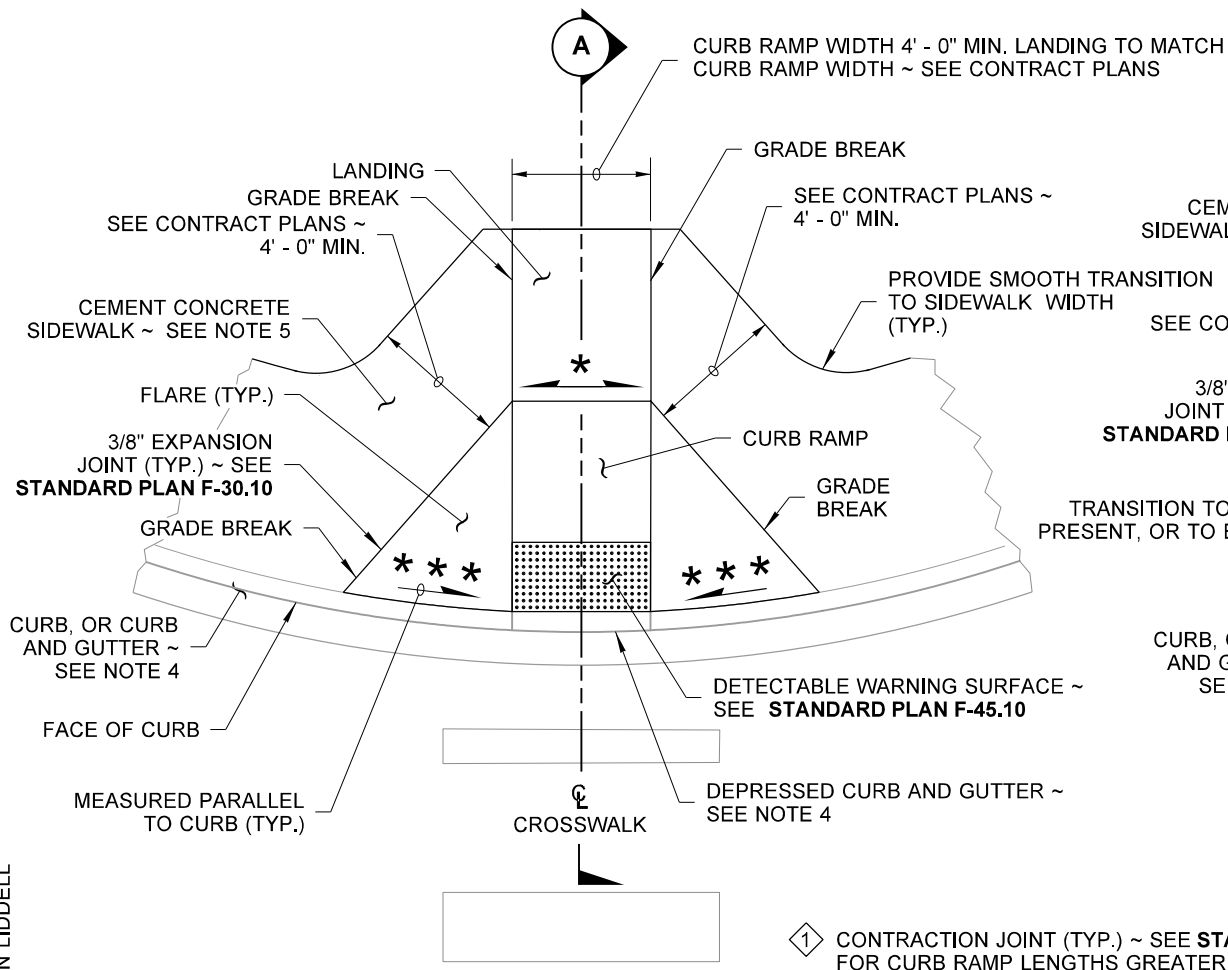

PLAN VIEW
TYPE PERPENDICULAR A

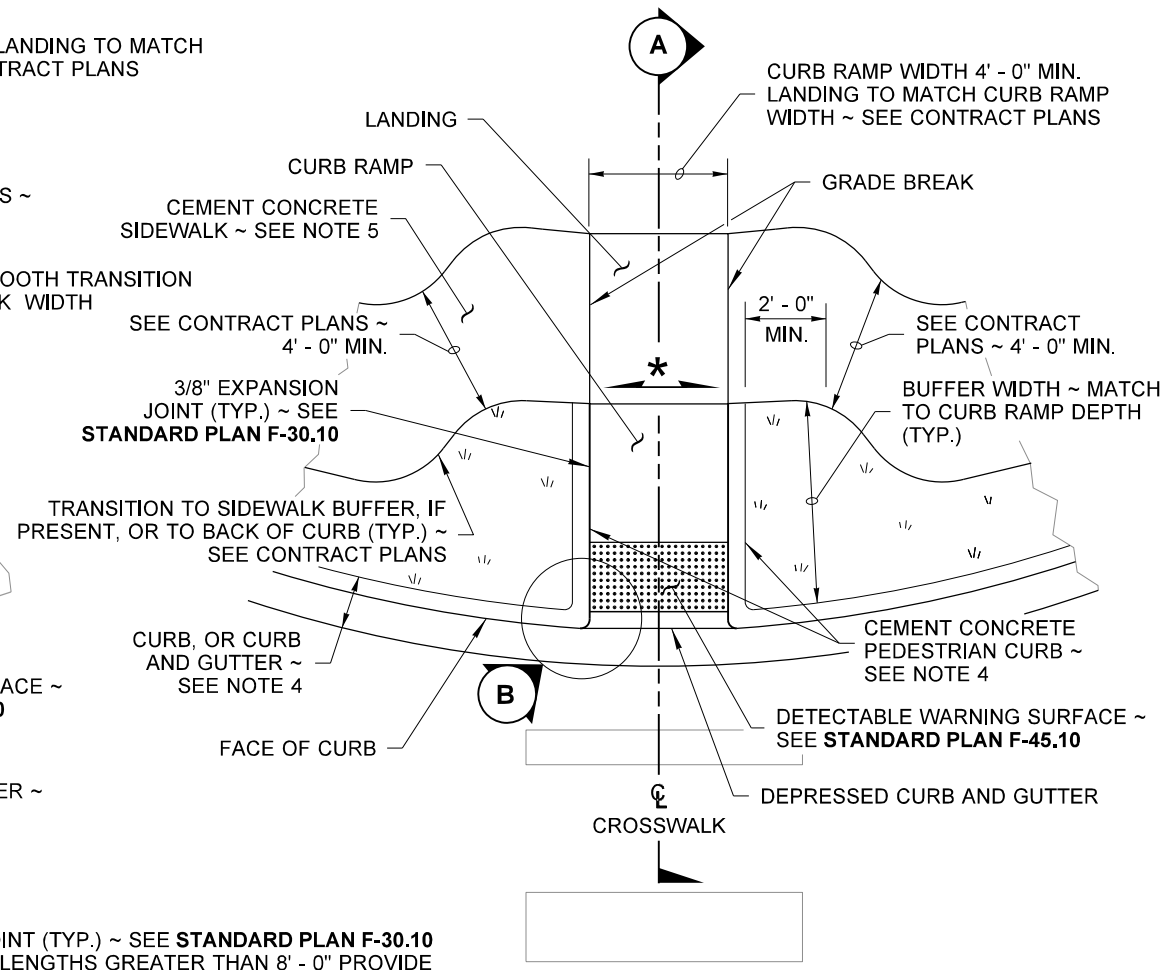

PLAN VIEW
TYPE PERPENDICULAR B
(SHOWN WITH BUFFER)

① CONTRACTION JOINT (TYP.) ~ SEE STANDARD PLAN F-30.10 FOR CURB RAMP LENGTHS GREATER THAN 8' - 0" PROVIDE CONTRACTION JOINT EQUALLY SPACED 4' - 0" MIN. OC.

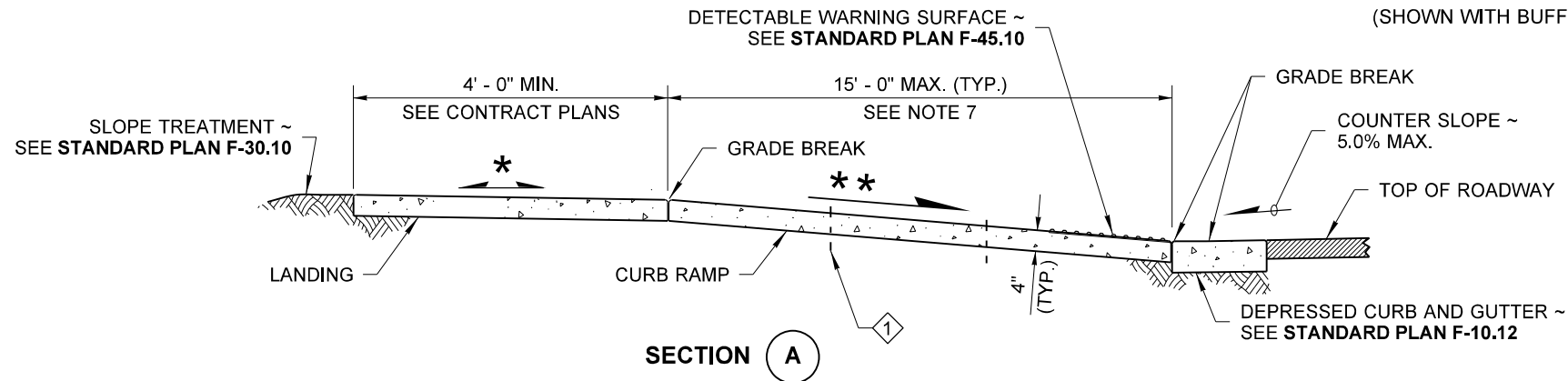

SECTION A

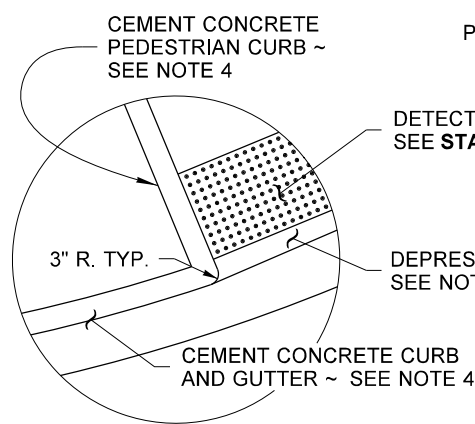

CURB RADIUS DETAIL (B)

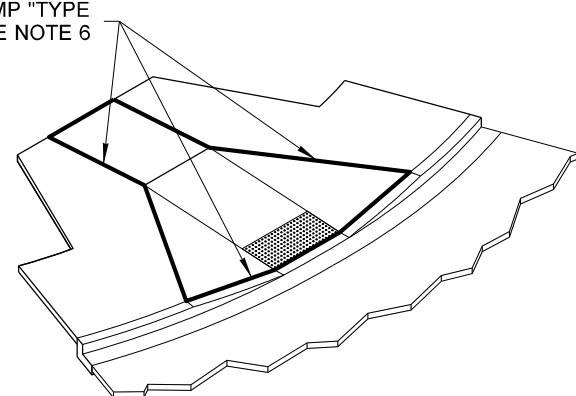

ISOMETRIC VIEW
TYPE PERPENDICULAR A PAY LIMIT

CEMENT CONCRETE CURB RAMP "TYPE PERPENDICULAR "B" PAY LIMIT ~ SEE NOTE 6

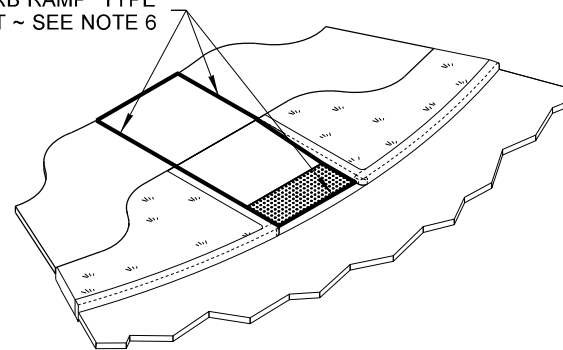

ISOMETRIC VIEW
TYPE PERPENDICULAR B PAY LIMIT

NOTES

- At marked crosswalks, the connection between the curb ramp and the roadway must be contained within the width of the crosswalk markings.
- Where "GRADE BREAK" is called out, the entire length of the grade break between the two adjacent surface planes shall be flush.
- Do not place Gratings, Junction Boxes, Access Covers, or other appurtenances on any part of the Curb Ramp or Landing, or in front of the Curb Ramp where it connects to the roadway.
- See Contract Plans for the curb design specified. See **Standard Plan F-10.12** for Curb, Curb and Gutter, Depressed Curb and Gutter, and Pedestrian Curb details.
- See **Standard Plan F-30.10** for Cement Concrete Sidewalk Details. See Contract Plans for width and placement of sidewalk.
- The Bid Item "Cement Concrete Curb Ramp Type ___" does not include the adjacent Curb, Curb and Gutter, Depressed Curb and Gutter, Pedestrian Curb, or Sidewalks.
- The Curb Ramp length is not required to exceed 15 feet (unless shown otherwise in the Contract Plans). When applying the 15-foot max. length, the running slope of the Curb Ramp is allowed to exceed 8.3%. Use a single constant slope from bottom of ramp to top of ramp to match into the landing over a horizontal distance of 15 feet. Do not include the abutting landing in the 15-foot max. measurement.
- Curb Ramps and Landings shall receive a broom finish. See **Standard Specifications 8-14**.
- Pedestrian Curb may be omitted if the ground surface at the back of the Curb Ramp and/or Landing will be at the same elevation as the Curb Ramp or Landing and there will not be material to retain.

LEGEND

- SLOPE IN EITHER DIRECTION
- * 1.5% OR FLATTER RECOMMENDED FOR DESIGN/FORMWORK (2% MAX.)
- ** 7.5% OR FLATTER RECOMMENDED FOR DESIGN/FORMWORK (8.3% MAX.)
- *** 9.5% OR FLATTER RECOMMENDED FOR DESIGN/FORMWORK (10% MAX.)



Digitally signed by R. Scott Zeller
Date: 2020.09.22 13:23:53 -07'00'

PERPENDICULAR CURB RAMP
STANDARD PLAN F-40.15-04

SHEET 1 OF 1 SHEET

APPROVED FOR PUBLICATION
Date: 2020.09.25 14:44:37 -07'00'
STATE DESIGN ENGINEER
Washington State Department of Transportation

DRAWN BY: FERN LIDDELL

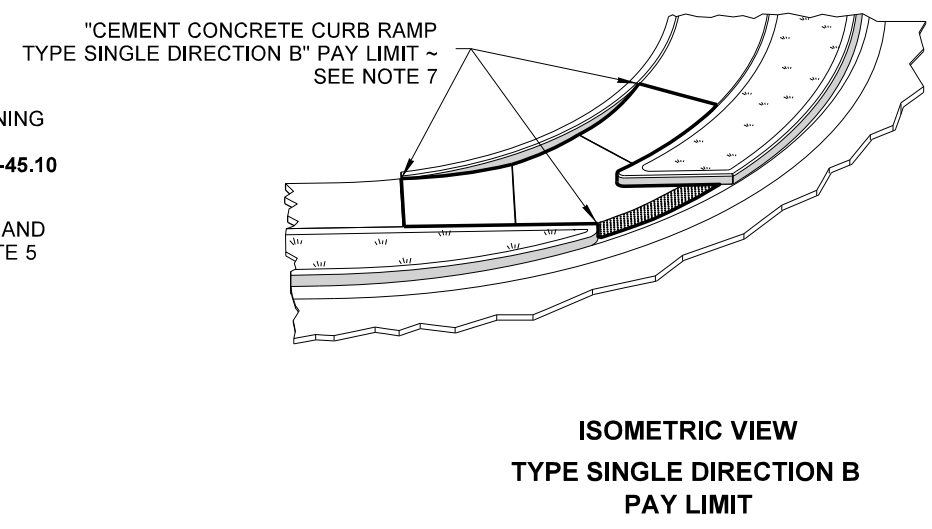
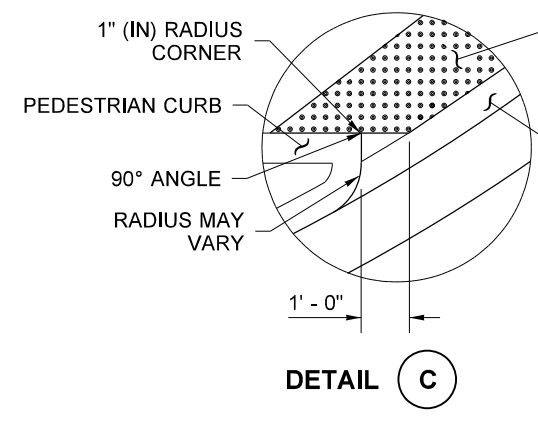
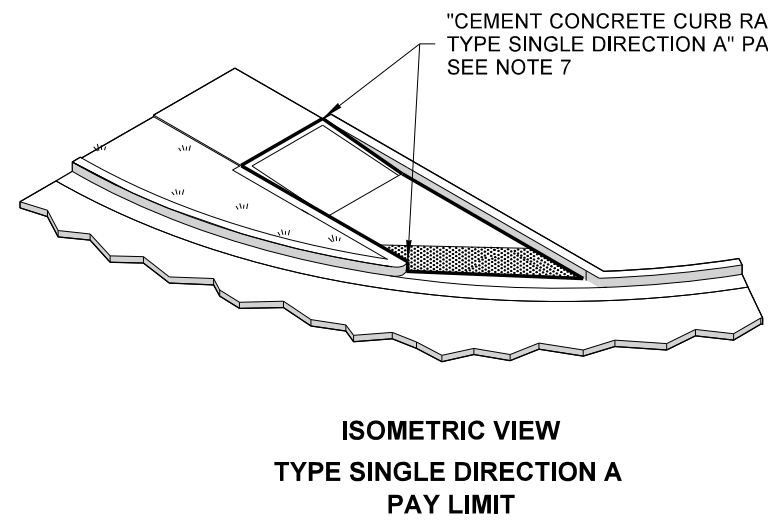
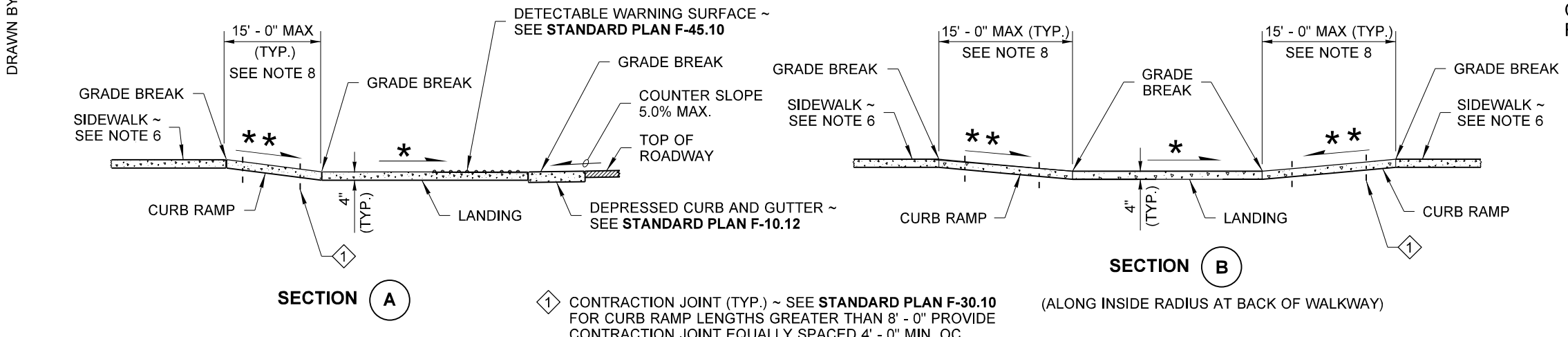
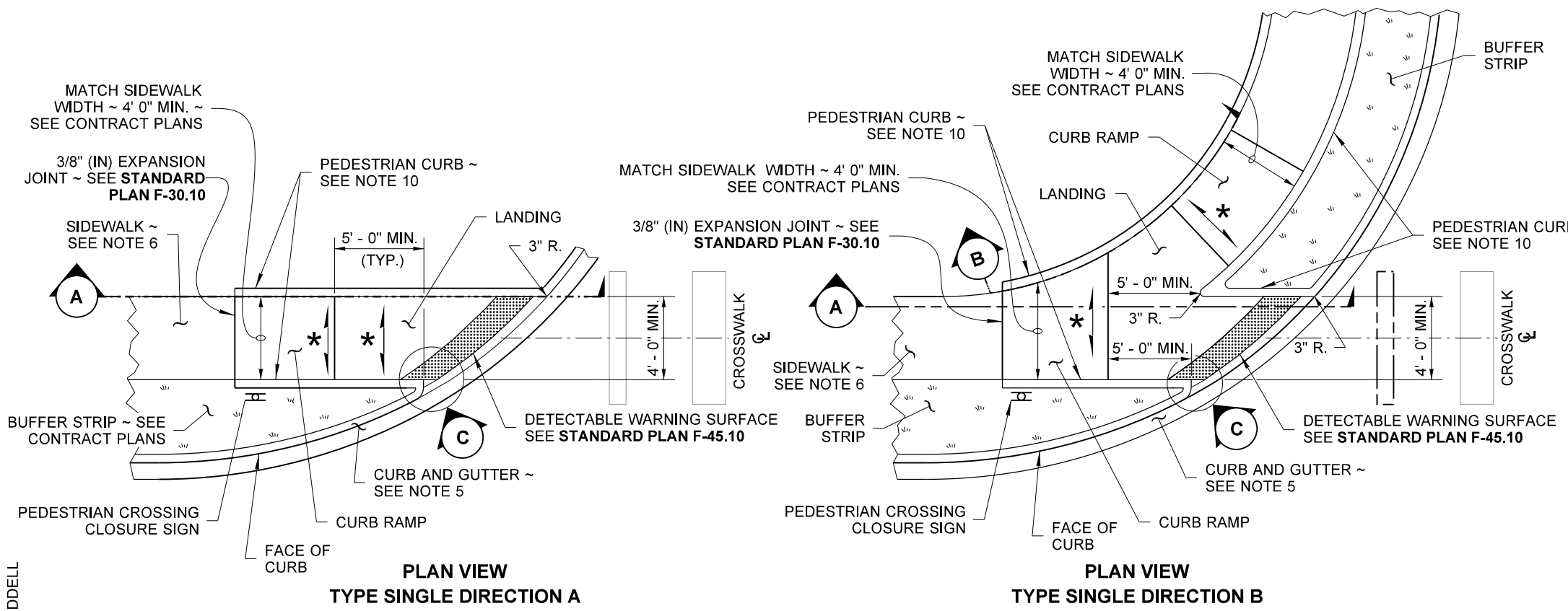

NOTES

1. This plan is to be used where pedestrian crossing in one direction is not permitted.
2. At marked crosswalks, the connection between the Landing and the roadway must be contained within the width of the crosswalk markings.
3. Where "GRADE BREAK" is called out, the entire length of the grade break between the two adjacent surface planes shall be flush.
4. Do not place Gratings, Junction Boxes, Access Covers, or other appurtenances on any part of the Curb Ramp or Landing or in the Depressed Curb and Gutter where the Landing connects to the roadway.
5. See Contract Plans for the curb design specified. See **Standard Plan F-10.12** for Curb, Curb and Gutter, Depressed Curb, Gutter and Pedestrian Curb details.
6. See **Standard Plan F-30.10** for Cement Concrete Sidewalk Details. See Contract Plans for width and placement of sidewalk.
7. The Bid Item "Cement Concrete Curb Ramp Type ___" does not include the adjacent Curb, Curb and Gutter, Depressed Curb and Gutter, Pedestrian Curb, or Sidewalks.
8. The Curb Ramp length is not required to exceed 15 feet (unless shown otherwise in the Contract Plans). When applying the 15-foot max. length (measured from back of sidewalk) the running slope of the curb ramp is allowed to exceed 8.3%. Use a single constant slope from bottom of ramp to top of ramp to match into the sidewalk over a horizontal distance of 15 feet.
9. Curb Ramps and Landings shall receive a broom finish. See **Standard Specifications 8-14**.
10. Pedestrian Curb may be omitted if the ground surface at the back of the Curb Ramp and/or Landing will be at the same elevation as the Curb Ramp or Landing and there will not be material to retain.

LEGEND

- SLOPE IN EITHER DIRECTION
- 1.5 OR FLATTER RECOMMENDED FOR DESIGN/FORMWORK (2% MAX.)
- 7.5% OR FLATTER RECOMMENDED FOR DESIGN/FORMWORK (8.3% MAX.) SEE NOTE 7

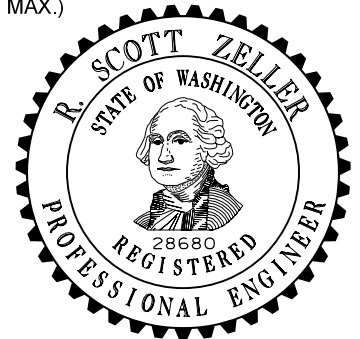

SINGLE DIRECTION CURB RAMP
STANDARD PLAN F-40.16-03

SHEET 1 OF 1 SHEET

APPROVED FOR PUBLICATION

STATE DESIGN ENGINEER
 Washington State Department of Transportation

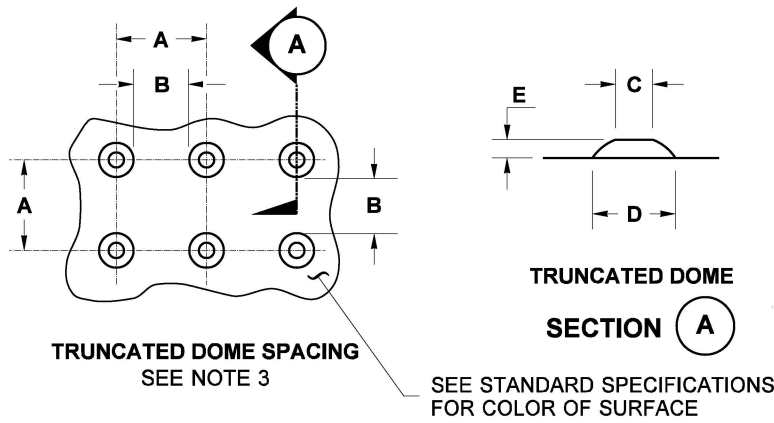

	MIN.	MAX.
A	1.60"	2.40"
B	0.65"	—
C	0.45"	0.90"
D	0.9"	1.40"
E	0.2"	0.2"

TRUNCATED DOME DETAILS

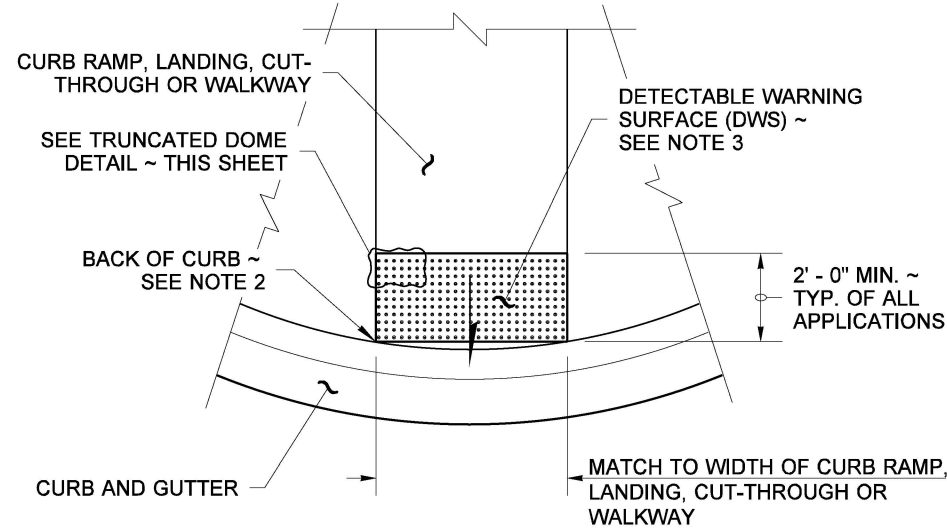

NOTES

1. Permanent Detectable Warning Surfaces (DWS) shall extend the full width of the curb ramp, landing, or other roadway entrance as applicable. Exception: If the Manufacturer of the DWS requires a concrete border around the DWS, a variance of up to 2" (in) on each side of the DWS is permitted.
2. Permanent Detectable Warning Surfaces (DWS) shall be placed on a minimum 4" (in) thick concrete pad. The DWS panel shall be placed adjacent to the back of the curb and with no more than a 2" (in) gap between the DWS and the back of the curb measured at the center of the DWS panel. Exception: If the Manufacturer of the selected DWS requires a concrete border around the DWS, a variance of up to 2" (in) from the back of the curb is permitted (measured at the leading corners of the DWS panel).
3. The rows of truncated domes shall be aligned to be parallel to the direction of travel, and perpendicular to the grade break at the back of curb.
4. If curb and gutter are not present, such as a shared-use path connection, the Detectable Warning Surface shall be placed at the pavement edge.
5. See **Standard Plans** for sidewalk and curb ramp details.
6. If a curb ramp is required, the location of the Detectable Warning Surface must be at the bottom of the ramp and within the required distance from the rail crossing.
7. When the grade break between the curb ramp and the landing is less than or equal to 5 ft. from the back of curb at all points, place the Detectable Warning Surface on the bottom of the curb ramp directly above the grade break.
8. Glued or stick down Detectable Warning Surfaces are allowed only for temporary work zone applications.

DRAWN BY: FERN LIDDELL

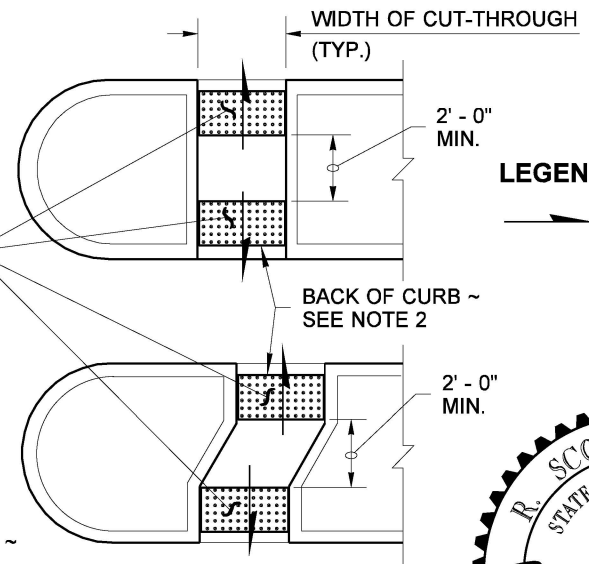
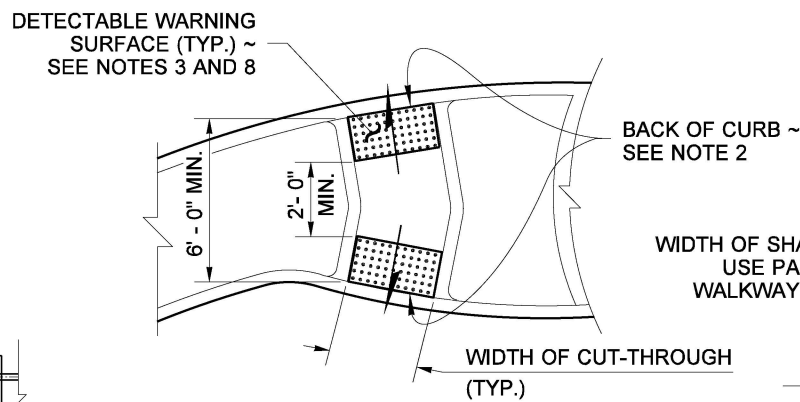
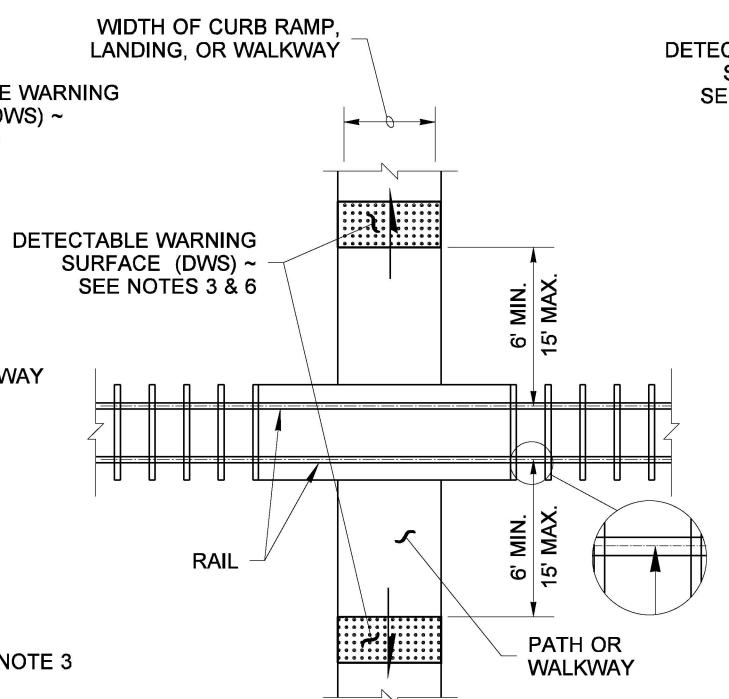
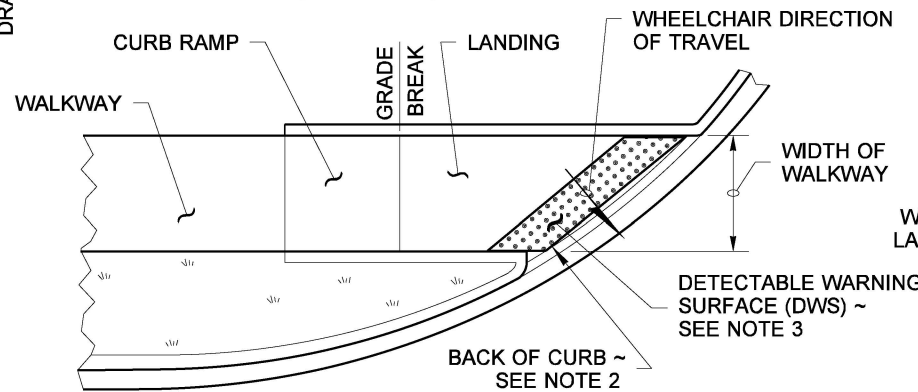
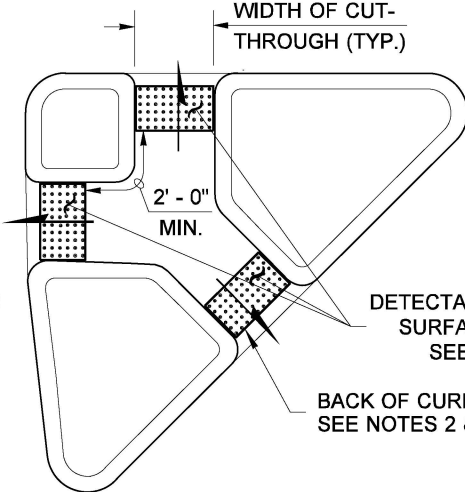
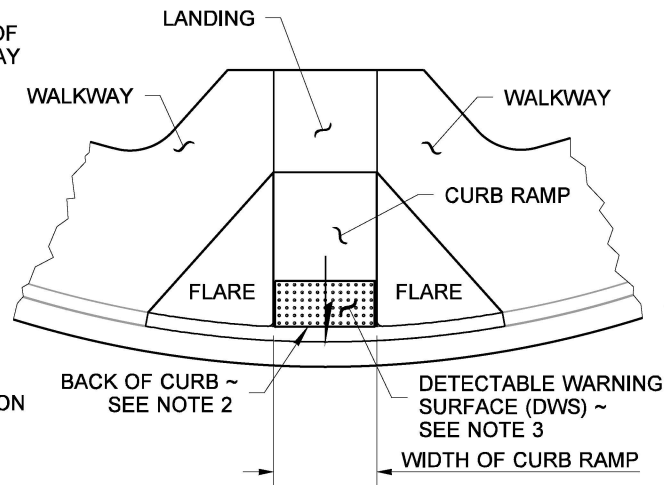
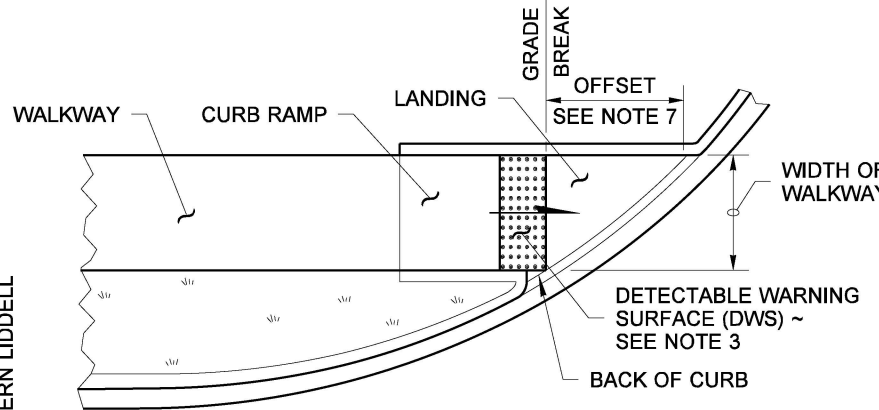

LEGEND
DIRECTION OF TRAVEL

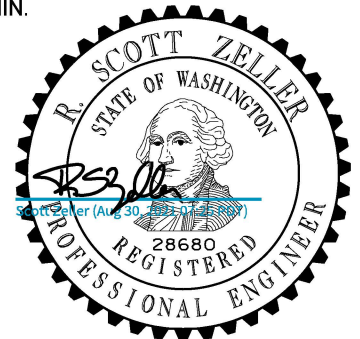
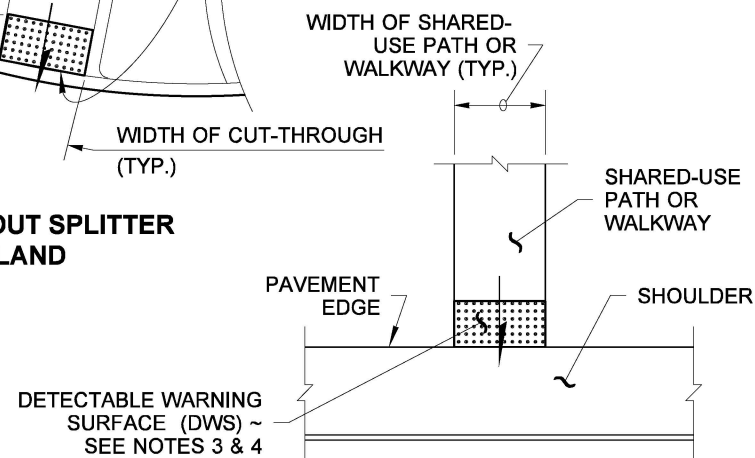
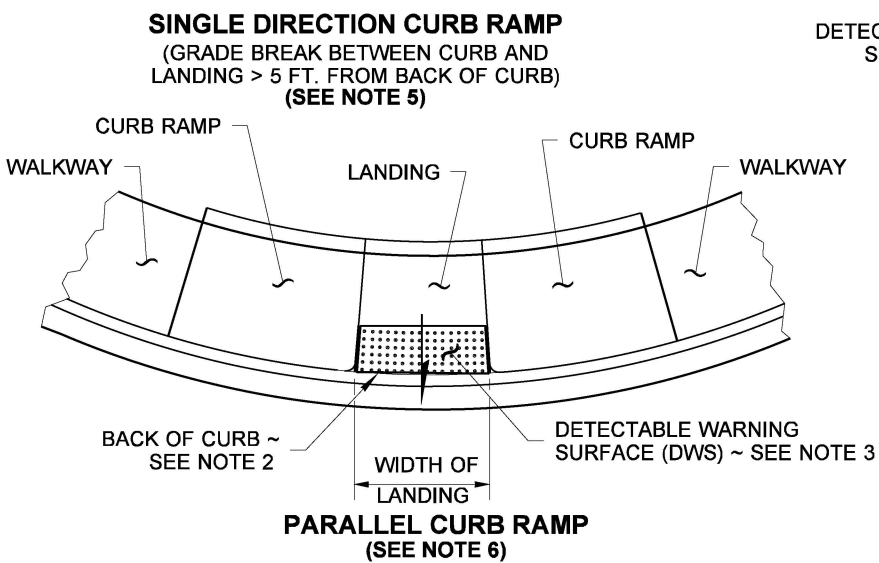

Aug 30, 2021

DETECTABLE WARNING SURFACE

STANDARD PLAN F-45.10-03

SHEET 1 OF 1 SHEET

APPROVED FOR PUBLICATION

[Signature]

Aug 31, 2021

STATE DESIGN ENGINEER

Washington State Department of Transportation

PLACEMENT GUIDELINES

BUFFER DATA										
LONGITUDINAL BUFFER SPACE = B										
SPEED (MPH)	25	30	35	40	45	50	55	60	65	70
LENGTH (FEET)	155	200	250	305	360	425	495	570	645	-
BUFFER VEHICLE ROLL AHEAD DISTANCE = R										
TRANSPORTABLE ATTENUATOR MINIMUM HOST VEHICLE WEIGHT 15,000 LBS. THE MAXIMUM WEIGHT SHALL BE IN ACCORDANCE WITH THE MANUFACTURERS RECOMMENDATION.								30 FEET MIN. TO 100 FEET MAX.		
PROTECTIVE VEHICLE MAY BE A WORK VEHICLE STRATEGICALLY LOCATED TO SHIELD THE WORK AREA.								NO SPECIFIED DISTANCE REQUIRED		

SIGN SPACING = X (1)		
RURAL HIGHWAYS	60 / 65 MPH	800' ±
RURAL ROADS	45 / 55 MPH	500' ±
RURAL ROADS & URBAN ARTERIALS	35 / 40 MPH	350' ±
RURAL ROADS, URBAN ARTERIALS, RESIDENTIAL & BUSINESS DISTRICTS	25 / 30 MPH	200' ± (2)
URBAN STREETS	25 MPH OR LESS	100' ± (2)

(1) ALL SPACINGS MAY BE ADJUSTED TO ACCOMMODATE INTERSECTIONS AND DRIVEWAYS.
(2) THIS SPACING MAY BE REDUCED IN URBAN AREAS TO FIT ROADWAY CONDITIONS.

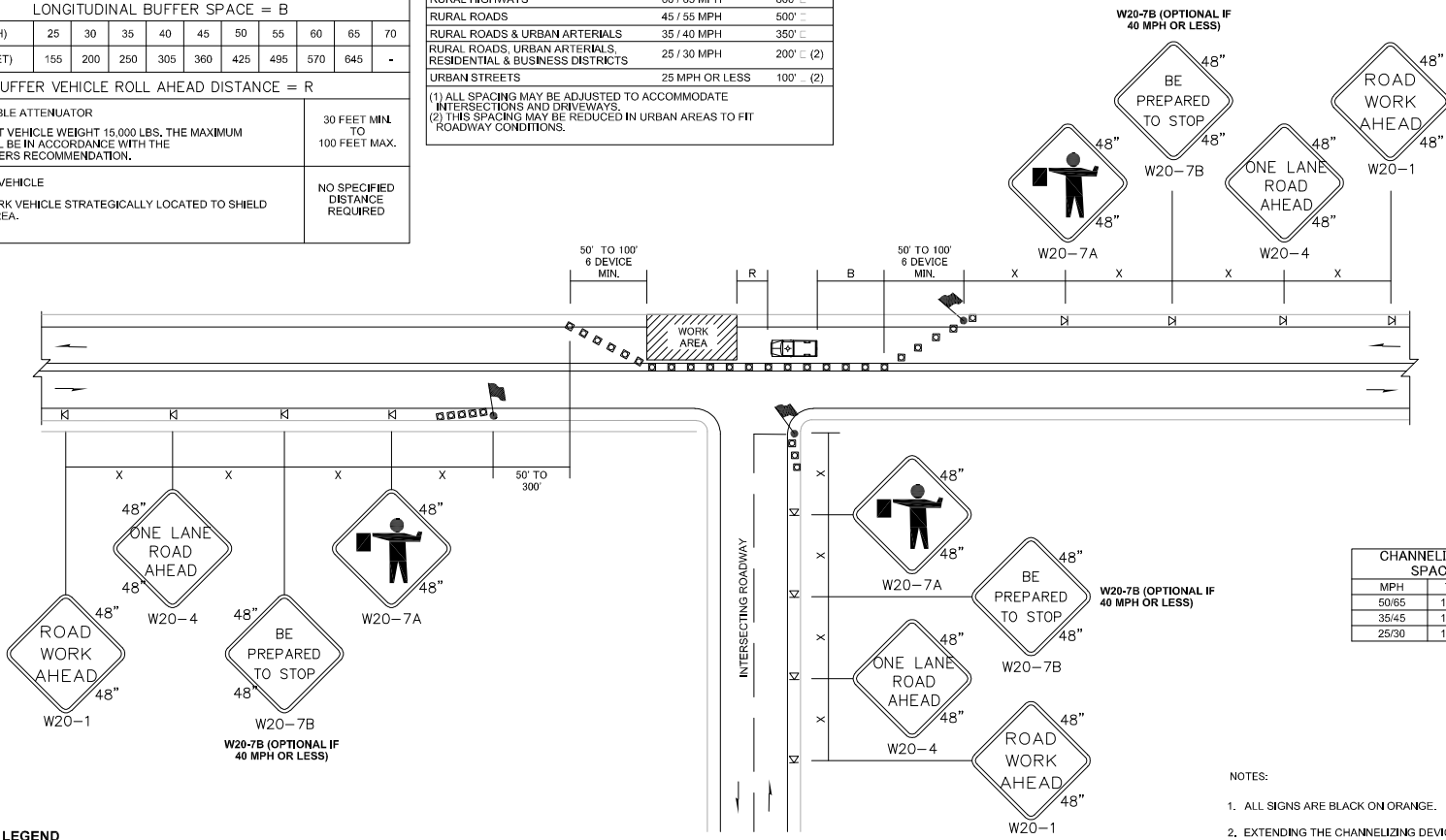

CHANNELIZATION DEVICE SPACING (FEET)		
MPH	TAPER	TANGENT
50/65	10 TO 20	80
35/45	10 TO 20	60
25/30	10 TO 20	40

- NOTES:
1. ALL SIGNS ARE BLACK ON ORANGE.
 2. EXTENDING THE CHANNELIZING DEVICE TAPER ACROSS SHOULDER IS RECOMMENDED.
 3. NIGHT WORK REQUIRES ADDITIONAL ROADWAY LIGHTING AT FLAGGING STATIONS. SEE THE STANDARD SPECIFICATIONS FOR ADDITIONAL DETAILS.
 4. SEE SPECIAL PROVISIONS FOR WORK HOUR RESTRICTIONS.

ONE-LANE, TWO-WAY TRAFFIC CONTROL

WITH FLAGGERS

NOT TO SCALE

- LEGEND
- FLAGGING STATION
 - TEMPORARY SIGN LOCATION
 - CHANNELIZING DEVICES
 - PROTECTIVE VEHICLE

CITY OF Federal Way
Centered on Opportunity

33325 8th Avenue South
Federal Way, WA 98003-6325

(253) 835-2700
www.cityoffederalway.com

811
Know what's below.
Call 811 before you dig.



TRAFFIC CONTROL DETAIL
ONE-LANE TWO FLAGGERS

SIGN SPACING = X (1)		
RURAL ROADS	45 / 55 MPH	500' □
RURAL ROADS & URBAN ARTERIALS	35 / 40 MPH	350' □
RURAL ROADS & URBAN ARTERIALS	25 / 30 MPH	200' □ (2)
RESIDENTIAL & BUSINESS DISTRICTS		
URBAN STREETS	25 MPH OR LESS	100' □ (2)

(1) ALL SPACING MAY BE ADJUSTED TO ACCOMMODATE INTERCHANGE RAMP, AT GRADE INTERSECTIONS AND DRIVEWAYS.
 (2) THIS SPACING MAY BE REDUCED IN URBAN AREAS TO FIT ROADWAY CONDITIONS.

MINIMUM TAPER LENGTH = L (feet)										
LANE WIDTH (feet)	Posted Speed (mph)									
	25	30	35	40	45	50	55	60	65	70
10	105	150	205	270	450	500	-	-	-	-
11	115	165	225	295	495	550	-	-	-	-
12	125	180	245	320	540	600	-	-	-	-

CHANNELIZATION DEVICE SPACING (feet)		
MPH	TAPER	TANGENT
50	40	80
35/45	30	60
25/30	20	40

BUFFER DATA										
LONGITUDINAL BUFFER SPACE = B										
SPEED (MPH)	25	30	35	40	45	50	55	60	65	70
LENGTH (feet)	155	200	250	305	360	425	-	-	-	-

BUFFER VEHICLE ROLL AHEAD DISTANCE = R	
TRANSPORTABLE ATTENUATOR MINIMUM HOST VEHICLE WEIGHT 15,000 LBS. THE MAXIMUM WEIGHT SHALL BE IN ACCORDANCE WITH THE MANUFACTURERS RECOMMENDATION.	30 FEET MIN. TO 100 FEET MAX.
PROTECTIVE VEHICLE MAY BE A WORK VEHICLE STRATEGICALLY LOCATED TO SHIELD THE WORK AREA.	NO SPECIFIED DISTANCE REQUIRED

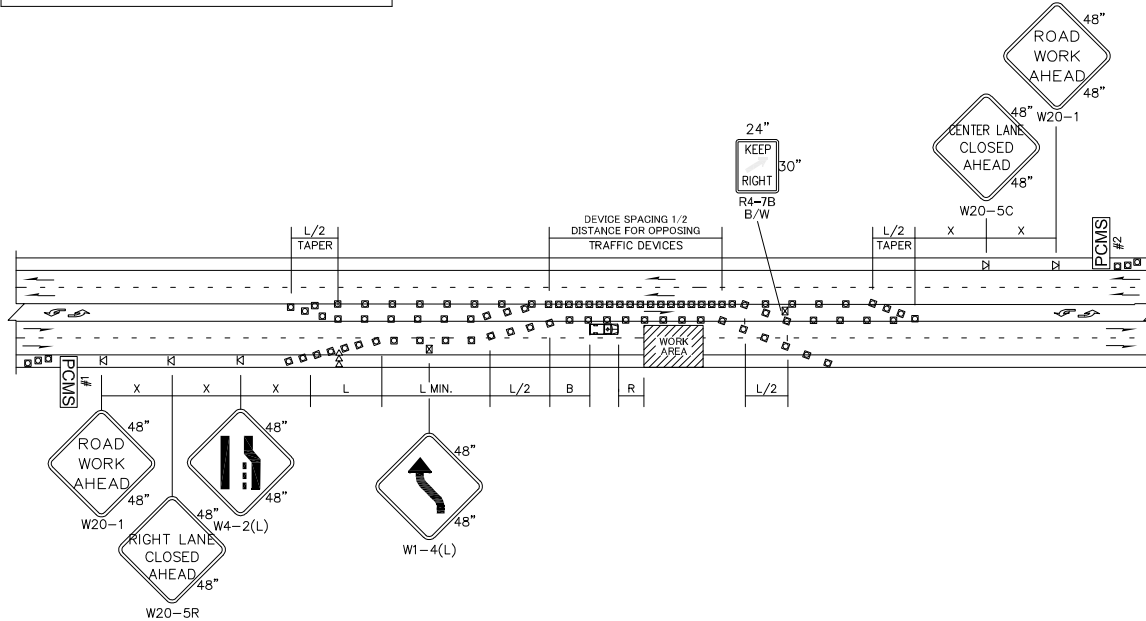

PCMS #1	
1	2
RIGHT LANE CLOSURE	1 MILE AHEAD
2.0 SEC	2.0 SEC

FIELD LOCATE IN ADVANCE OF TEMPORARY SIGNS.

PCMS #2	
1	2
CENTER LANE CLOSED	NNO LEFT TURNING
2.0 SEC	2.0 SEC

FIELD LOCATE IN ADVANCE OF TEMPORARY SIGNS.

- LEGEND**
- TEMPORARY SIGN LOCATION
 - CHANNELIZING DEVICES
 - ⇨⇨ SEQUENTIAL ARROW SIGN
 - ▬▬ PROTECTIVE VEHICLE
 - PCMS PORTABLE CHANGEABLE MESSAGE SIGN
 - ⊠ TEMPORARY SIGN LOCATION (5' MOUNTING HEIGHT)

RIGHT LANE CLOSURE WITH SHIFT – 5 LANE ROADWAY

NOT TO SCALE

- NOTES:
- SEE SPECIAL PROVISIONS FOR WORK HOUR RESTRICTIONS.
 - RECOMMEND EXTENDING DEVICE TAPER (L/3) ACROSS SHOULDER.
 - FOR POSTED SPEED LIMITS OF 30 MPH OR LESS, USE SIGN W1-3 IN LIEU OF SIGN W1-4.
 - ALL SIGNS ARE BLACK ON ORANGE UNLESS OTHERWISE DESIGNATED.